

CURTISS - WRIGHT

EXLAR[®]

Automation
Solutions

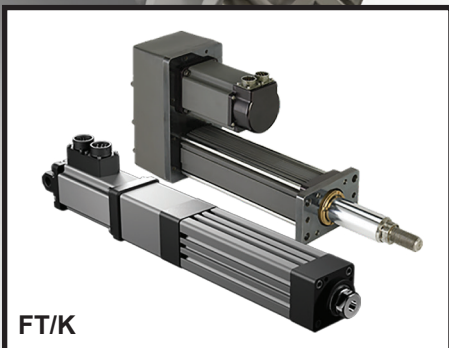

2023

Global Leader in Actuator Technology

Your Actuator Solution Source

The Exlar® product offerings cover a wide range of performance specifications and capabilities. Please view the chart below as a thumbnail guide to assist you in choosing the best product for your application. Three product families shown in the table below are not included in this catalog, but are offered in separate brochures as offered below. You may also visit www.exlar.com to download the brochures and view complete specifications.

Linear Actuators	Series	Standard Environmental Rating	Integrated Control Electronics	Integrated Brushless Motor	Nominal Frame Sizes in (mm)	Max Stroke Length in (mm)	Max Cont. Force lbf (kN)	Max Velocity in/sec (mm/sec)
GS Series Integrated Motor/Actuator	GSX	IP65S		S	2-7 inch	18 (455)	12,389 (55.1)	40.0 (1,016)
Tritex II AC Integrated Drive /Motor/Actuator	T2X	IP65S	S	S	90, 115 mm	18 (455)	3,685 (16.4)	37.5 (953)
Tritex II DC Integrated Drive /Motor/Actuator	TDX	IP65S	S	S	60, 75 mm	18 (455)	955 (4.2)	33.3 (847)
FT Series Universal Actuator	FT	IP65S*			3-8 inch	48 (1,225)	40,000 (178)	59.3 (1,500)
K Series Universal Actuator	KX	IP65S			60, 75, 90 mm	48 (1,225)	3,500 (15.6)	33.8 (833)

*Base unit only

O = Available option

S = Standard

Rotary Actuators	Series	Standard Environmental Rating	Integrated Control Electronics	Integrated Planetary Gearhead	Frame Sizes in (mm)	Max Cont. Torque in-lbf (Nm)	Max Velocity RPM
Tritex II AC Rotary Gearmotor	R2G	IP65S	S	S	75, 90, 115 mm	4,066 (459)	1,000
Tritex II AC Rotary Motor	R2M					95 (10.7)	4,000
Tritex II DC Rotary Gearmotor	RDG	IP65S	S	S	60, 75, 90 mm	1,798 (203)	1,250
Tritex II DC Rotary Motor	RDM					42 (4.8)	5,000
Brushless Rotary Gearmotor	SLG	IP65S		S	60, 75, 90, 115 mm	4,696 (530)	1,250
Brushless Rotary Motor	SLM	IP65S			60, 75, 90, 115, 142, 180 mm	615 (69.49)	5,000

	page
ROLLER SCREW TECHNOLOGY.....	2
<u>GSX SERIES LINEAR ACTUATORS</u>	3
<i>Mechanical Specifications</i>	7
<i>Drawings</i>	24
<i>Ordering Guide</i>	33
<u>TRITEX II SERIES</u>	34
<u>TRITEX II AC ACTUATORS</u>	42
<i>AC Linear</i>	46
<i>AC Rotary</i>	58
<i>Ordering Guide</i>	65
<u>TRITEX II DC ACTUATORS</u>	68
<i>DC Linear</i>	71
<i>DC Rotary</i>	81
<i>Ordering Guide</i>	88
<u>FT SERIES LINEAR ACTUATORS</u>	92
<i>Mechanical Specifications</i>	96
<i>Drawings</i>	104
<i>Ordering Guide</i>	118
<u>K SERIES LINEAR ACTUATORS</u>	119
<i>Mechanical Specifications</i>	124
<i>Drawings</i>	130
<i>Ordering Guide</i>	138
<u>SLM AND SLG SERIES ROTARY MOTORS AND GEARMOTORS</u>	139
<i>Mechanical Specifications</i>	143
<i>Drawings</i>	154
<i>Ordering Guide</i>	159
<u>CABLE SELECTION GUIDE</u>	160
<u>ENGINEERING REFERENCE</u>	164
<u>TERMS AND CONDITIONS</u>	176

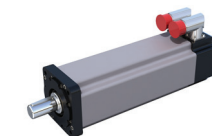
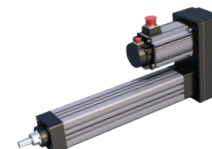
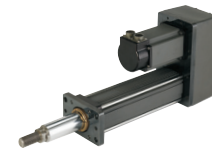

The Advantages of Roller Screw Technology

Designers have five basic choices when it comes to achieving controlled linear motion. Because the roller screw technology common to all Exlar linear actuators might not be familiar to everyone using this catalog, allow us to present a general overview.

Roller Screw Basics

A roller screw is a mechanism for converting rotary torque into linear motion in a similar manner to acme screws or ball screws. Unlike those devices, roller screws can carry heavy loads for thousands of hours in the most arduous conditions. This makes roller screws the ideal choice for demanding, continuous-duty applications.

The difference is in the way the roller screw is designed to transmit forces. Multiple threaded helical rollers are assembled in a planetary arrangement around a threaded shaft (shown below) which converts the motor's rotary motion into linear movement of the shaft or nut.



Exlar Roller Screws vs Hydraulics & Pneumatics

In applications where high loads are anticipated or faster cycling is desired, Exlar's roller screw actuators provide an attractive alternative to the hydraulic or pneumatic options. With their vastly simplified controls, electro-mechanical units using roller screws have major advantages.

- Eliminates the need for a complex support system of valves, pumps, filters and sensors.
- Requires much less space.
- Extends working life.
- Minimizes maintenance.
- Eliminates hydraulic fluid leaks.
- Reduces noise levels.
- Allows the flexibility of computer programmed positioning.

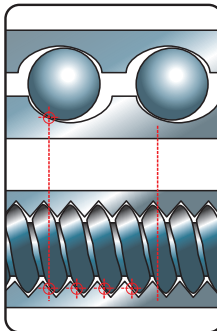

Exlar Roller Screws vs Ball Screws Performance

Loads and Stiffness: Due to design factors, the number of contact points in a ball screw is limited by the ball size. Exlar's planetary roller screw designs provide many more contact points than possible on comparably sized ball screws. Since the number of contact points is greater, roller screws have greater load carrying capacities, plus improved stiffness. Plus an Exlar roller screw actuator takes up much less space to meet the designer's specified load rating.

Travel Life: As you would expect, with their higher load capacities, roller screws deliver major advantages in working life. Usually measured in "Inches of Travel," the relative travel lives for roller and ball screws are displayed on the graph on page 3. As shown, in a 2,000 lb. average load application applied to a 1.2 inch screw diameter with a 0.2 inch lead, the roller screw will have an expected service life that is 15 times greater than that of the ball screw.

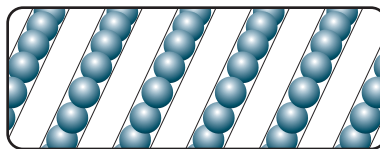

Speeds: Typical ball screw speeds are limited to 2000 rpm and less, due to the interaction of the balls colliding with each other as the race rotates. In contrast, the rollers in a roller screw are

fixed in planetary fashion by journals at the ends of the nut and therefore do not have this limitation. Hence, roller screws can work at 5000 rpm and higher, producing comparably higher linear travel rates.

[Return to Table of Contents](#)

GSX SERIES

INTEGRATED SERVO MOTOR AND ACTUATOR

High quality screw for longer life

Ideal hydraulic replacement

Powerful and robust

Compact size

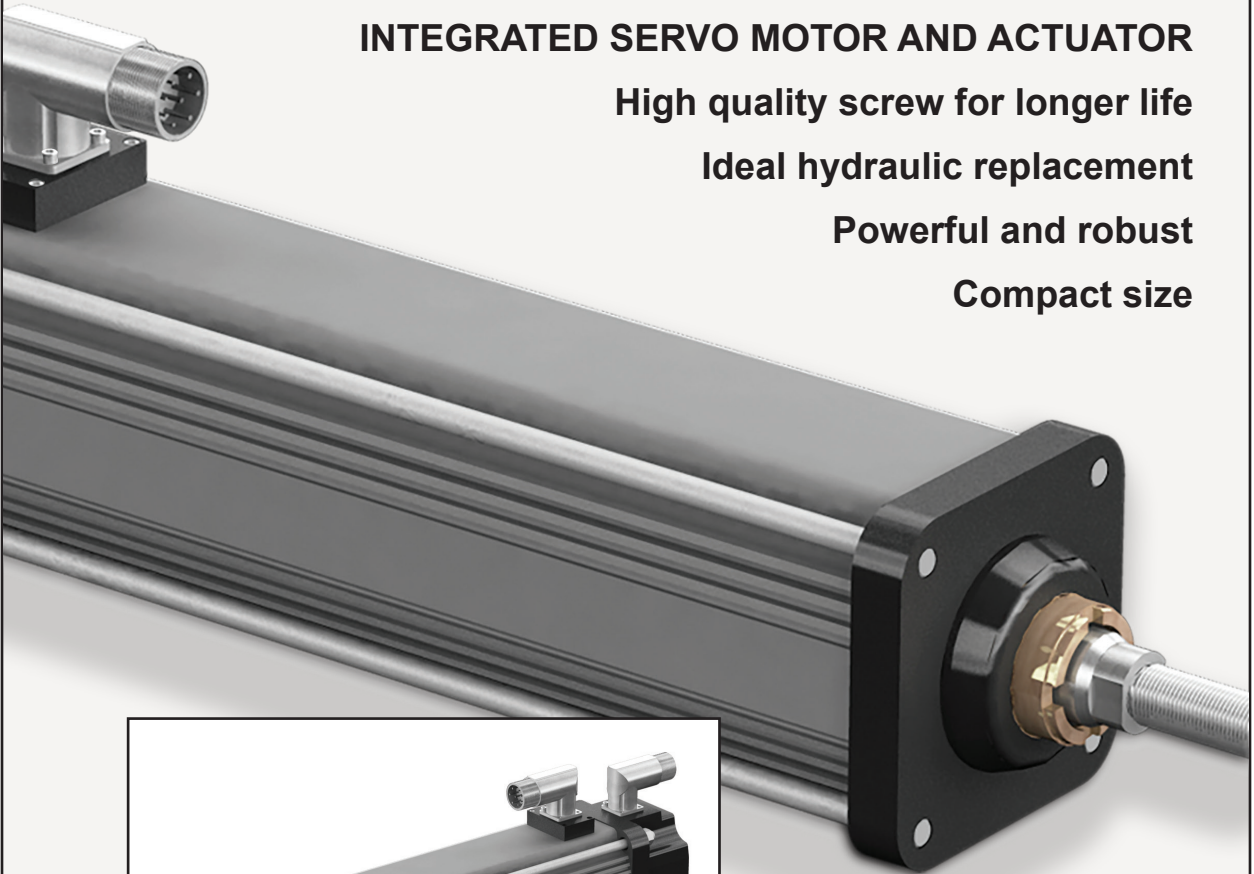

GSX Series Integrated Motor/Actuator

GSX Series

High Capacity Integrated Motor/Actuator

Description

For applications that require long life and continuous duty, even in harsh environments, the GSX Series actuator offers a robust solution. The life of these actuators can exceed that of a ball screw actuator by 15 times, all while delivering high speeds and high forces.

Sealed for Long Life with Minimum Maintenance

GSX Series actuators have strong advantages wherever outside contaminants are an issue. In most rotary-to-linear devices, critical mechanisms are exposed to the environment. Thus, these actuators must be frequently inspected, cleaned and lubricated.

In contrast, the converting components in all Exlar GSX units are mounted within sealed motor housing. With a simple bushing and seal on the smooth extending rod, abrasive particles or other contaminants are prevented from reaching the actuator's critical mechanisms. This assures trouble-free operation even in the most harsh environments.

Similarly, lubrication requirements are minimal. GSX actuators can be lubricated with either grease or recirculated oil. Recirculated oil systems eliminate this type of maintenance altogether. A GSX Series actuator with a properly operating recirculating oil system will operate indefinitely, without any other lubrication requirements.

Feature	Standard	Optional
External anti-rotate mechanism	No	Yes
Internal Anti-rotate Mechanism	No	Yes
Electric brake	No	Yes
External Limit Switches	No	Yes
Connectors	Right Angle, Rotatable	
Mounting Style	Extended Tie Rods, Side Tapped Mounting Holes, Trunnion, Rear Clevis, Front or Rear Flange	
Rod End	Male or Female: U.S. Standard or Metric	Specials available to meet OEM requirements
Lubrication	Greased, Oil Connection Ports are Built-in for Customer Supplied Recirculated Oil Lubrication	
Primary Feedback	Standard Encoders or Resolvers to Meet Most Amplifier Requirements	

Technical Characteristics	
Frame Sizes in (mm)	2 (50.8), 3 (76.2), 4 (101.6), 5.5 (139.7), 7 (177.8)
Screw Leads in (mm)	0.1 (2), 0.2 (5), 0.25 (6), 0.4 (10), 0.5 (13), 0.75 (19), 1 (25)
Standard Stroke Lengths	3 (76), 4 (102), 6 (152), 8 (203), 10 (254), 12 (305), 14 (357), 18 (457)
Force Range	103 to 11,528 lbf (458 to 51 kN)
Maximum Speed	up to 37.5 in/sec (952 mm/s)

Operating Conditions and Usage		
Accuracy:		
Screw Lead Error	in/ft (µm / 300 mm)	0.001 (25)
Screw Travel Variation	in/ft (µm / 300 mm)	0.0012 (30)
Screw Lead Backlash	in	0.004 maximum
Ambient Conditions:		
Standard Ambient Temperature	°C	0 to 65
Extended Ambient Temperature*	°C	-30 to 65
Storage Temperature	°C	-40 to 85
IP Rating		IP65S
Vibration**		3.5 grms; 5 to 520 hz

* Consult Exlar for extended temperature operations

** Resolver feedback

Ratings at 25°C, operation over 25°C requires de-rating.

Product Features

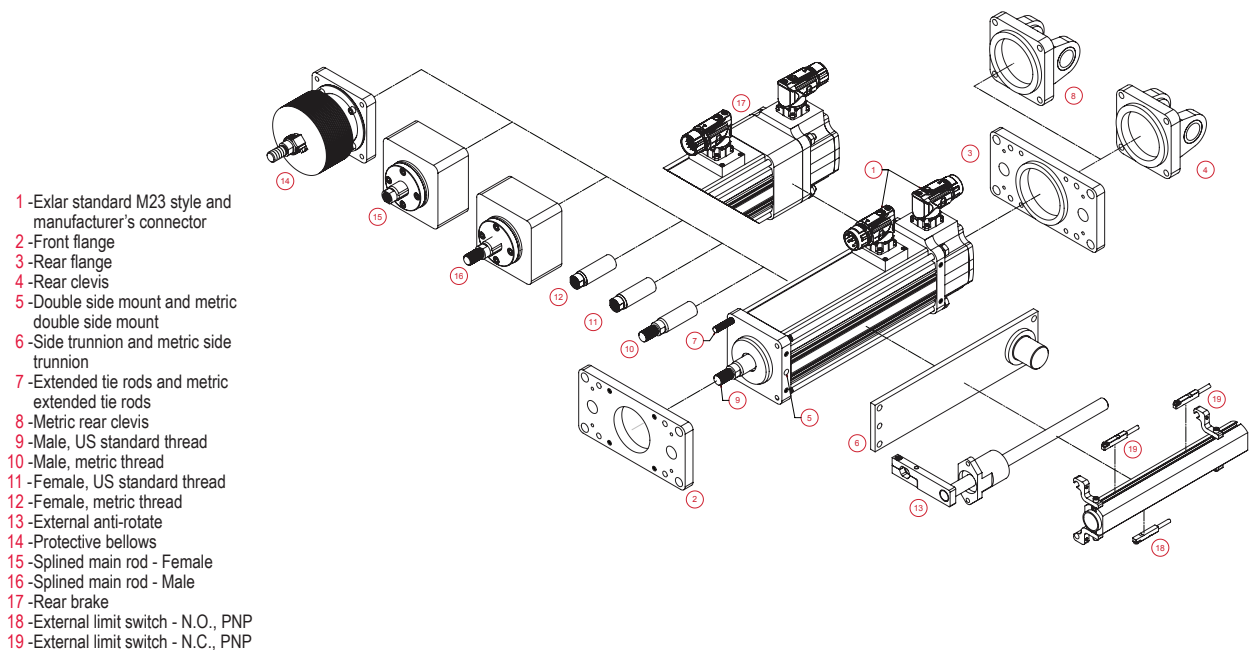
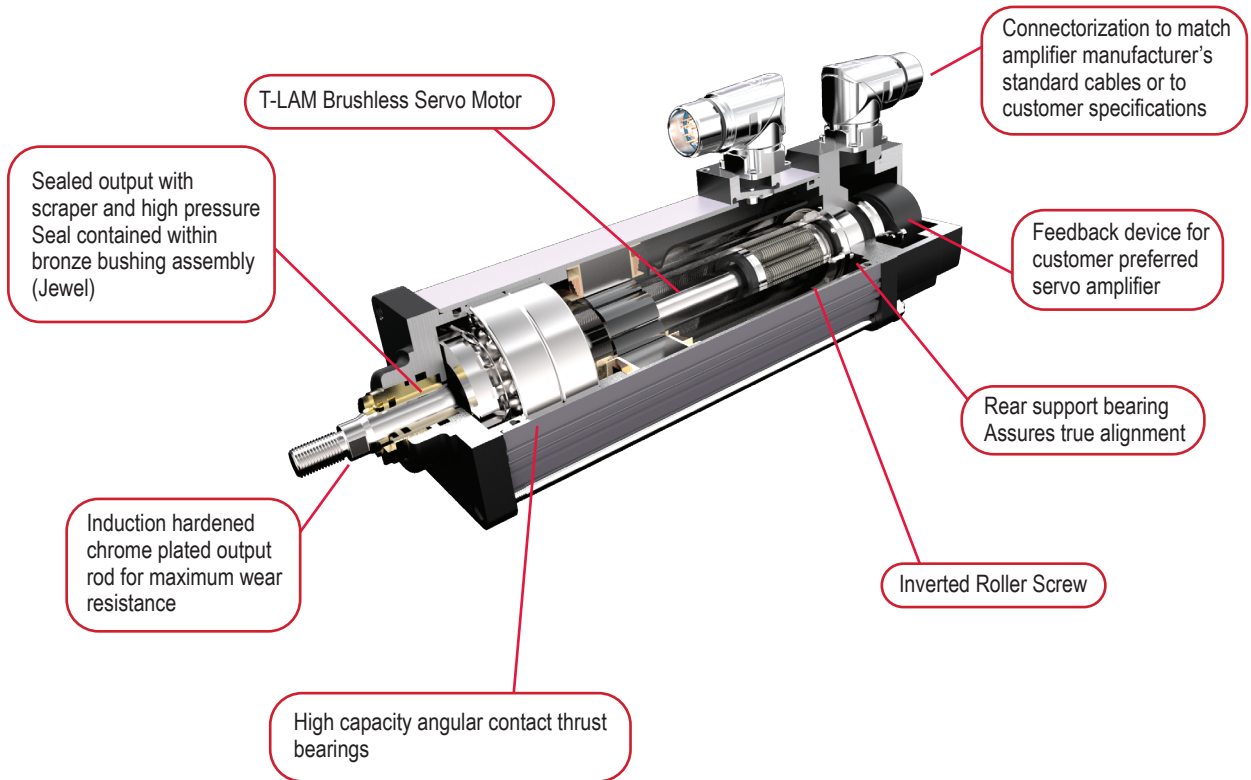

GSX Series Integrated Motor/Actuator

Industries and Applications:

Hydraulic cylinder replacement
Ball screw replacement
Pneumatic cylinder replacement

Automotive

Dispensing
Welding
Pressing
Riveting / Fastening / Joining

Food Processing

Sealing
Dispensing
Forming
Pick and Place Systems
Fillers
Cutting / Slicing / Cubing

Sawmill/Forestry

Saw Positioning
Fence Positioning
Ventilation Control Systems

Machining

Material Cutting
Broaching
Metal Forming
Tube Bending
Stamping

Entertainment / Simulation

Animatronics
Training Simulators
Ride Automation

Medical Equipment

Volumetric Pumps
Patient Positioning

Plastics

Die Cutters
Part Eject
Core Pull
Formers

Material Handling

Nip Roll Positioning
Tension Control
Web Guidance
Wire Winding

Test

Fatigue Testing
Load Simulation Testing

Repeatable force, reliable positioning accuracy, and flexible control make GSX actuators a perfect fit for assembly presses or test stands.

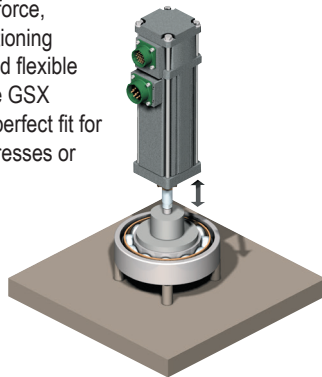

Repeatable force control plus positioning accuracy extends the life of costly tools when Exlar linear actuators are used for precision applications.

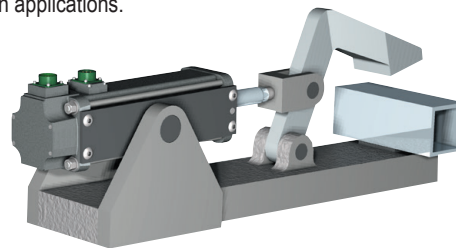

[Return to Table of Contents](#)

Mechanical Specifications

GSX20

Model No. (Motor Stacks)		1 Stack			2 Stack			3 Stack	
Screw Lead Designator		01	02	04	01	02	04	02	04
Screw Lead	in	0.1	0.2	0.4	0.1	0.2	0.4	0.2	0.4
	mm	2.54	5.08	10.16	2.54	5.08	10.16	5.08	10.16
Continuous Force (Motor Limited)	lbf	367	195	103	578	307	163	409	216
	N	1632	867	459	2571	1366	723	1817	962
Max Velocity	in/sec	8.3	16.8	33.3	8.3	16.8	33.3	16.8	33.3
	mm/sec	211.7	423.3	845.8	211.7	423.3	845.8	423.3	845.8
Friction Torque (standard screw)	in-lbf	1.0			1.1			1.1	
	N-m	0.11			0.12			0.12	
Friction Torque (preloaded screw)	in-lbf	2.3			2.3			2.3	
	N-m	0.25			0.26			0.26	
Min Stroke	in	3			3			6	
	mm	76			76			152	
Max Stroke	in	12			12			12	
	mm	305			305			305	
C _a (Dynamic Load Rating)	lbf	2075	1540	1230	2075	1540	1230	1540	1230
	N	9230	6850	5471	9230	6850	5471	6850	5471
Inertia (zero stroke)	lb-in-s ²	0.0007758			0.0008600			0.0009442	
	Kg-m ²	0.00008766			0.00009717			0.0001067	
Inertia Adder (per inch of stroke)	lb-in-s ² /in				0.00004667				
	Kg-m ² /in				0.000005273				
Weight (zero stroke)	lb	4.5			5.0			5.5	
	Kg	2.04			2.27			2.49	
Weight Adder (per inch of stroke)	lb				0.5				
	Kg				0.23				

GSX30

Model No. (Motor Stacks)		1 Stack			2 Stack			3 Stack	
Screw Lead Designator		01	02	05	01	02	05	02	05
Screw Lead	in	0.1	0.2	0.5	0.1	0.2	0.5	0.2	0.5
	mm	2.54	5.08	12.7	2.54	5.08	12.7	5.08	12.7
Continuous Force (Motor Limited)	lbf	792	449	190	1277	724	306	1020	432
	N	3521	1995	845	5680	3219	1363	4537	1922
Max Velocity	in/sec	5.0	10.0	25.0	5.0	10.0	25.0	10.0	25.0
	mm/sec	127.0	254.0	635.0	127.0	254.0	635.0	254.0	635.0
Friction Torque (standard screw)	in-lbf	1.5			1.7			1.9	
	N-m	0.17			0.19			0.21	
Friction Torque (preloaded screw)	in-lbf	3.3			3.5			3.7	
	N-m	0.37			0.39			0.41	
Min Stroke	in	3			3			6	
	mm	76			76			152	
Max Stroke	in	18			18			18	
	mm	457			457			457	
C _a (Dynamic Load Rating)	lbf	5516	5800	4900	5516	5800	4900	5800	4900
	N	24536	25798	21795	24536	25798	21795	25798	21795
Inertia (zero stroke)	lb-in-s ²	0.002655			0.002829			0.003003	
	Kg-m ²	0.0003000			0.0003196			0.00033963	
Inertia Adder (per inch of stroke)	lb-in-s ² /in				0.0001424				
	Kg-m ² /in				0.00001609				
Weight (zero stroke)	lb	6.5			7.65			8.8	
	Kg	2.95			3.47			3.99	
Weight Adder (per inch of stroke)	lb				1.1				
	Kg				0.50				

*See definitions on page 9

GSX Series Integrated Motor/Actuator

GSX40

Model No. (Motor Stacks)	1 Stack				2 Stack				3 Stack				
Screw Lead Designator	01	02	05	08	01	02	05	08	02	05	08		
Screw Lead	in	0.1	0.2	0.5	0.75	0.1	0.2	0.5	0.75	0.2	0.5	0.75	
	mm	2.54	5.08	12.7	19.05	2.54	5.08	12.7	19.05	5.08	12.7	19.05	
Continuous Force (Motor Limited)	lbf	2089	1194	537	358	3457	1975	889	593	2687	1209	806	
	N	9293	5310	2390	1593	15377	8787	3954	2636	11950	5378	3585	
Max Velocity	in/sec	5.0	10.0	25.0	37.5	5.0	10.0	25.0	37.5	10.0	25.0	37.5	
	mm/sec	127.0	254.0	635.0	953.0	127.0	254.0	635.0	953.0	254.0	635.0	953.0	
Friction Torque (standard screw)	in-lbf	2.7				3.0				3.5			
	N-m	0.31				0.34				0.40			
Friction Torque (preloaded screw)	in-lbf	7.2				7.5				8.0			
	N-m	0.82				0.85				0.91			
Min Stroke	in	4				6				8			
	mm	102				152				203			
Max Stroke	in	18		12		18		12		18		12	
	mm	457		305		457		305		457		305	
C _s (Dynamic Load Rating)	lbf	7900	8300	7030	6335	7900	8300	7030	6335	8300	7030	6335	
	N	35141	36920	31271	28179	35141	36920	31271	28179	36920	31271	28179	
Inertia (zero stroke)	lb-in-s ²	0.01132				0.01232				0.01332			
	Kg-m ²	0.0012790				0.001392				0.001505			
Inertia Adder (per inch of stroke)	lb-in-s ² /in					0.0005640							
	Kg-m ² /in					0.00006372							
Weight (zero stroke)	lb	8.0				11.3				14.6			
	Kg	3.63				5.13				6.62			
Weight Adder (per inch of stroke)	lb					2.0							
	Kg					0.91							

GSX50

Model No. (Motor Stacks)	1 Stack				2 Stack				3 Stack				
Screw Lead Designator	01	02	05	10	01	02	05	10	02	05	10		
Screw Lead	in	0.1	0.2	0.5	1.0	0.1	0.2	0.5	1.0	0.2	0.5	1.0	
	mm	2.54	5.08	12.7	25.4	2.54	5.08	12.7	25.4	5.08	12.7	25.4	
Continuous Force (Motor Limited)	lbf	4399	2578	1237	619	7150	4189	2011	1005	5598	2687	1344	
	N	19568	11466	5503	2752	31802	18634	8944	4472	24901	11953	5976	
Max Velocity	in/sec	4.0	8.0	20.0	40.0	4.0	8.0	20.0	40.0	8.0	20.0	40.0	
	mm/sec	101.6	203.0	508.0	1016.0	101.6	203.0	508.0	1016.0	203.0	508.0	1016.0	
Friction Torque (standard screw)	in-lbf	4.1				4.6				5.3			
	N-m	0.46				0.53				0.60			
Friction Torque (preloaded screw)	in-lbf	10.1				10.6				11.3			
	N-m	1.14				1.21				1.36			
Min Stroke	in	6				6				10			
	mm	152				152				254			
Max Stroke	in	10	14		10	10	14		10	14		10	
	mm	254	356		254	254	356		254	356		254	
C _s (Dynamic Load Rating)	lbf	15693	13197	11656	6363	15693	13197	11656	6363	13197	11656	6363	
	N	69806	58703	51848	28304	69806	58703	51848	28304	58703	51848	28304	
Inertia (zero stroke)	lb-in-s ²	0.02084				0.02300				0.02517			
	Kg-m ²	0.002356				0.002599				0.002844			
Inertia Adder (per inch of stroke)	lb-in-s ² /in					0.001208							
	Kg-m ² /in					0.0001365							
Weight (zero stroke)	lb	46.0				53.0				60.0			
	Kg	20.87				24.04				27.2			
Weight Adder (per inch of stroke)	lb					3.0							
	Kg					1.36							

*See definitions on page 9

GSX60

Model No. (Motor Stacks)		1 Stack			2 Stack			3 Stack		
Screw Lead Designator		03	05	10	03	05	10	03	05	10
Screw Lead	in	0.25	0.5	1.0	0.25	0.5	1	0.25	0.5	1
	mm	6.35	12.7	25.4	6.35	12.7	25.4	6.35	12.7	25.4
Continuous Force (Motor Limited)	lbf	4937	2797	1481	8058	4566	2417	11528	6533	3459
	N	21958	12443	6588	35843	20311	10753	51278	29058	15383
Max Velocity	in/sec	10.0	20.0	40.0	10.0	20.0	40.0	10.0	20.0	40.0
	mm/sec	254.0	508.0	1016.0	254.0	508.0	1016.0	254.0	508.0	1016.0
Friction Torque (standard screw)	in-lbf		8.1			10.8			14.5	
	N-m		0.91			1.22			1.64	
Friction Torque (preloaded screw)	in-lbf		14.1			16.8			20.5	
	N-m		1.59			1.90			2.32	
Min Stroke	in		6			10			10	
	mm		152			254			254	
Max Stroke	in		10			10			10	
	mm		254			254			254	
C _a (Dynamic Load Rating)	lbf	25300	22800	21200	25300	22800	21200	25300	22800	21200
	N	112540	101420	94302	112540	101420	94302	112540	101420	94302
Inertia (zero stroke)	lb-in-s ²		0.0804			0.1114			0.1424	
	Kg-m ²		0.009087			0.01259			0.01609	
Inertia Adder (per inch of stroke)	lb-in-s ² /in					0.005190				
	Kg-m ² /in					0.0005864				
Weight (zero stroke)	lb		48			62			76	
	Kg		21.77			28.12			34.47	
Weight Adder (per inch of stroke)	lb					8.0				
	Kg					3.63				

DEFINITIONS:

Continuous Force: The linear force produced by the actuator at continuous motor torque.

Max Velocity: The linear velocity that the actuator will achieve at rated motor rpm.

Friction Torque (standard screw): Amount of torque required to move the actuator when not coupled to a load.

Friction Torque (preloaded screw): Amount of torque required to move the actuator when not coupled to a load.

Min Stroke: Shortest available stroke length.

Max Stroke: Longest available stroke length.

C_a (Dynamic Load Rating): A design constant used when calculating the estimated travel life of the roller screw.

Inertia (zero stroke): Base inertia of an actuator with zero available stroke length.

Inertia Adder (per inch of stroke): Inertia per inch of stroke that must be added to the base (zero stroke) inertia to determine the total actuator inertia.

Weight (zero stroke): Base weight of an actuator with zero available stroke length.

Weight Adder (per inch of stroke): Weight adder per inch of stroke that must be added to the base (zero stroke) weight to determine the total actuator weight.

GSX Series Integrated Motor/Actuator

Weight Adders of GSX Accessories

Weight Adders of GSX Accessories	GSX20		GSX30		GSX40		GSX50		GSX60	
	lbs	kg	lbs	kg	lbs	kg	lbs	kg	lbs	kg
Front Flange Mount	0.7	0.3	1.7	0.8	4.0	1.8	10.8	4.9	15.2	6.9
Rear Flange Mount	1.0	0.5	1.8	0.8	5.0	2.3	12.8	5.8	30.4	13.7
Side Mount	0.0	0.0	0.0	0.0	0.0	0.0	0.0	0.0	0.0	0.0
Extended Tie Rod	0.0	0.0	0.1	0.0	0.2	0.1	0.3	0.2	0.5	0.2
Side Trunnion	0.8	0.3	0.8	0.3	1.8	0.8	4.6	2.1	9.3	4.2
3 inch Stroke	2.2	1.0	2.8	1.3	NA	NA	NA	NA	NA	NA
4 inch Stroke	NA	NA	NA	NA	5.1	2.3	NA	NA	NA	NA
6 inch Stroke	3.1	1.4	3.6	1.6	5.9	2.7	14.3	6.5	26.6	12.1
8 inch Stroke	NA	NA	NA	NA	6.7	3.0	NA	NA	NA	NA
10 inch Stroke	3.9	1.8	5.0	2.3	7.5	3.4	17.7	8.0	32.3	14.7
12 inch Stroke	4.4	2.0	5.7	2.6	8.2	3.8	NA	NA	NA	NA
14 inch Stroke	NA	NA	6.9	3.1	NA	NA	21.1	9.6	NA	NA
18 inch Stroke	NA	NA	7.6	3.5	10.6	4.8	NA	NA	NA	NA
Rear Clevis Mount w/ Pin	0.4	0.2	1.1	0.5	1.9	0.8	5.1	2.3	13.6	6.2
Anti-Rotation (incl. flange)	1.1	0.5	2.6	1.2	5.3	2.4	6.6	3.0	21.0	10.0
External Limit Switch (incl. AR)	1.2	0.5	2.8	1.2	5.6	2.5	6.9	3.1	21.4	9.7
3 inch Stroke	1.4	0.6	3.0	1.4	NA	NA	NA	NA	NA	NA
6 inch Stroke	1.5	0.7	3.2	1.5	6.0	2.7	7.8	3.5	22.2	10.1
8 inch Stroke	NA	NA	NA	NA	6.1	2.8	NA	NA	NA	NA
10 inch Stroke	1.6	0.7	3.5	1.6	6.3	2.8	8.1	3.7	22.4	10.2
12 inch Stroke	1.7	0.8	3.6	1.6	6.4	2.9	NA	NA	NA	NA
14 inch Stroke	NA	NA	3.7	1.7	NA	NA	8.5	3.9	NA	NA
18 inch Stroke	NA	NA	3.9	1.8	6.7	3.1	NA	NA	NA	NA
Splined Main Rod	0.3	0.1	1.0	0.5	2.2	1.0	4.8	2.2	14.8	6.7
Protective Bellows	0.2	0.1	0.3	0.1	0.3	0.2	0.4	0.2	0.9	0.4
Rod Clevis	0.2	0.1	0.5	0.2	1.4	0.6	3.5	1.6	8.2	3.7
Spherical Rod Eye	0.2	0.1	0.2	0.1	0.7	0.3	1.6	0.7	NA	NA
Rod Eye	0.2	0.1	0.3	0.2	1.2	0.5				

*All weights are approximate

Electrical Specifications

GSX20

Motor Stator		118	138	158	168	218	238	258	268	318*	338*	358*	368*
Bus Voltage	Vrms	115	230	400	460	115	230	400	460	115	230	400	460
Speed @ Bus Voltage	rpm	5000											
RMS SINUSOIDAL COMMUTATION													
Continuous Motor Torque	lbf-in	7.6	7.3	7.0	7.0	11.9	11.5	11.0	11.3	15.0	15.3	14.6	14.9
	Nm	0.86	0.83	0.79	0.79	1.34	1.30	1.25	1.28	1.70	1.73	1.65	1.69
Torque Constant (Kt) (+/- 10% @ 25°C)	lbf-in/A	2.5	5.2	7.5	9.5	2.5	5.2	8.6	10.1	2.5	5.3	8.8	10.1
	Nm/A	0.28	0.59	0.85	1.07	0.28	0.59	0.97	1.15	0.29	0.59	0.99	1.15
Continuous Current Rating	(Greased) A	3.4	1.6	1.0	0.8	5.4	2.5	1.4	1.2	6.6	3.2	1.9	1.6
	(Oil Cooled) A	6.9	3.1	2.1	1.6	10.8	4.9	2.9	2.5	13.2	6.5	3.7	3.3
Peak Current Rating	A	6.9	3.1	2.1	1.6	10.8	4.9	2.9	2.5	13.2	6.5	3.7	3.3
O-PK SINUSOIDAL COMMUTATION													
Continuous Motor Torque	lbf-in	7.6	7.3	7.0	7.0	11.9	11.5	11.0	11.3	15.0	15.3	14.6	14.9
	Nm	0.86	0.83	0.79	0.79	1.34	1.30	1.25	1.28	1.70	1.73	1.65	1.69
Torque Constant (Kt) (+/- 10% @ 25°C)	lbf-in/A	1.7	3.7	5.3	6.7	1.7	3.7	6.1	7.2	1.8	3.7	6.2	7.2
	Nm/A	0.20	0.42	0.60	0.76	0.20	0.42	0.69	0.81	0.20	0.42	0.70	0.81
Continuous Current Rating	(Greased) A	4.9	2.2	1.5	1.2	7.6	3.5	2.0	1.8	9.4	4.6	2.6	2.3
	(Oil Cooled) A	9.7	4.5	2.9	2.3	15.2	7.0	4.1	3.5	18.7	9.2	5.3	4.7
Peak Current Rating	A	9.7	4.5	2.9	2.3	15.2	7.0	4.1	3.5	18.7	9.2	5.3	4.7
MOTOR STATOR DATA													
Voltage Constant (Ke) (+/- 10% @ 25°C)	Vrms/Krpm	16.9	35.5	51.5	64.8	16.9	35.5	58.6	69.3	17.3	36.0	59.9	69.3
	Vpk/Krpm	23.9	50.2	72.8	91.7	23.9	50.2	82.9	98.0	24.5	50.9	84.8	98.0
Pole Configuration		8	8	8	8	8	8	8	8	8	8	8	8
Resistance (L-L)(+/- 5% @ 25°C)	Ohms	2.6	12.5	28.8	45.8	1.1	5.3	15.5	20.7	0.76	3.1	9.6	12.2
Inductance (L-L)(+/- 15%)	mH	4.6	21.4	47.9	68.3	2.5	10.2	28.3	39.5	1.7	7.4	18.5	27.4
Brake Inertia	lbf-in-sec ²	0.00012											
	Kg-cm ²	0.135											
Brake Current @ 24 VDC	A	0.33											
Brake Holding Torque (Min)	lbf-in	22											
	Nm	2.5											
Brake Engage/Disengage Time	ms	14/28											
Mechanical Time Constant (tm), ms	min	4.7	5.1	5.5	5.6	2.0	2.1	2.3	2.2	1.3	1.2	1.4	1.3
	max	6.6	7.2	7.9	7.9	2.8	3.0	3.3	3.1	1.8	1.8	1.9	1.8
Electrical Time Constant (te)	ms	1.8	1.7	1.7	1.5	2.2	1.9	1.8	1.9	2.3	2.4	1.9	2.2
Insulation Class		180 (H)											

For amplifiers using peak sinusoidal ratings, multiply RMS sinusoidal Kt by 0.707 and current by 1.414.
 *Refer to performance specifications on page 7 for availability of 3 stack stator by stroke/lead combination.
 Test data derived using NEMA recommended aluminum heatsink 10" x 10" x 1/4" at 25°C ambient.

Specifications subject to change without notice.

GSX Series Integrated Motor/Actuator

GSX30

Motor Stator		118	138	158	168	218	238	258	268	318*	338*	358*	368*
Bus Voltage	Vrms	115	230	400	460	115	230	400	460	115	230	400	460
Speed @ Bus Voltage	rpm	3000											
RMS SINUSOIDAL COMMUTATION													
Continuous Motor Torque	lbf-in	16.9	16.8	16.3	16.0	26.9	27.1	26.7	27.0	38.7	38.2	36.2	36.3
	Nm	1.91	1.90	1.84	1.81	3.04	3.06	3.01	3.05	4.37	4.32	4.09	4.10
Torque Constant (Kt) (+/- 10% @ 25°C)	lbf-in/A	4.4	8.7	15.5	17.5	4.4	8.7	15.5	17.5	4.4	8.7	15.6	17.5
	Nm/A	0.49	0.99	1.75	1.97	0.49	0.99	1.75	1.97	0.50	0.98	1.77	1.98
Continuous Current Rating	(Greased) A	4.3	2.2	1.2	1.0	6.9	3.5	1.9	1.7	9.7	4.9	2.6	2.3
	(Oil Cooled) A	8.6	4.3	2.4	2.0	13.8	6.9	3.8	3.4	19.5	9.9	5.2	4.6
Peak Current Rating	A	8.6	4.3	2.4	2.0	13.8	6.9	3.8	3.4	19.5	9.9	5.2	4.6
O-PK SINUSOIDAL COMMUTATION													
Continuous Motor Torque	lbf-in	16.9	16.8	16.3	16.0	26.9	27.1	26.7	27.0	38.7	38.2	36.2	36.3
	Nm	1.91	1.90	1.84	1.81	3.04	3.06	3.01	3.05	4.37	4.32	4.09	4.10
Torque Constant (Kt) (+/- 10% @ 25°C)	lbf-in/A	3.1	6.2	11.0	12.4	3.1	6.2	11.0	12.4	3.1	6.1	11.1	12.4
	Nm/A	0.35	0.70	1.24	1.40	0.35	0.70	1.24	1.40	0.35	0.69	1.25	1.40
Continuous Current Rating:	(Greased) A	6.1	3.0	1.7	1.4	9.7	4.9	2.7	2.4	13.8	7.0	3.7	3.3
	(Oil Cooled) A	12.2	6.1	3.3	2.9	19.5	9.8	5.4	4.9	27.6	13.9	7.3	6.5
Peak Current Rating	A	12.2	6.1	3.3	2.9	19.5	9.8	5.4	4.9	27.6	13.9	7.3	6.5
MOTOR STATOR DATA													
Voltage Constant (Ke) (+/- 10% @ 25°C)	Vrms/Krpm	29.8	59.7	105.8	119.3	29.8	59.7	105.8	119.3	30.3	59.2	106.8	119.8
	Vpk/Krpm	42.2	84.4	149.7	168.7	42.2	84.4	149.7	168.7	42.9	83.7	151.0	169.4
Pole Configuration		8	8	8	8	8	8	8	8	8	8	8	8
Resistance (L-L)(+/- 5% @ 25°C)	Ohms	2.7	10.8	36.3	47.9	1.1	4.4	14.1	17.6	0.65	2.6	9.3	11.6
Inductance (L-L)(+/- 15%)	mH	7.7	30.7	96.8	123.0	3.7	14.7	46.2	58.7	2.5	9.5	30.9	38.8
Brake Inertia	lbf-in-sec ²	0.00033											
	Kg-cm ²	0.38											
Brake Current @ 24 VDC	A	0.5											
Brake Holding Torque (Min)	lbf-in	40											
	Nm	4.5											
Brake Engage/Disengage Time	ms	19/29											
Mechanical Time Constant (tm), ms	min	4.9	4.9	5.2	5.4	2.0	2.0	2.0	2.0	1.1	1.2	1.3	1.3
	max	9.4	9.5	10.1	10.5	3.9	3.8	3.9	3.8	2.2	2.3	2.5	2.5
Electrical Time Constant (te)	ms	2.9	2.8	2.7	2.6	3.3	3.4	3.3	3.3	3.8	3.7	3.3	3.3
Insulation Class		180 (H)											

For amplifiers using peak sinusoidal ratings, multiply RMS sinusoidal Kt by 0.707 and current by 1.414.
 *Refer to performance specifications on page 7 for availability of 3 stack stator by stroke/lead combination.
 Test data derived using NEMA recommended aluminum heatsink 10" x 10" x 3/8" at 25°C ambient.

Specifications subject to change without notice.

GSX Series Integrated Motor/Actuator

GSX40

Motor Stator		118	138	158	168	218	238	258	268	338*	358*	368*
Bus Voltage	Vrms	115	230	400	460	115	230	400	460	230	400	460
Speed @ Bus Voltage	rpm	3000										
RMS SINUSOIDAL COMMUTATION												
Continuous Motor Torque	lbf-in	47.5	47.5	45.9	45.4	75.1	78.6	78.7	79.5	106.9	105.3	106.9
	Nm	5.37	5.36	5.19	5.13	8.49	8.89	8.89	8.99	12.08	11.90	12.08
Torque Constant (Kt) (+/- 10% @ 25°C)	lbf-in/A	4.1	8.2	14.5	16.8	4.1	8.2	14.5	16.8	8.4	14.5	16.8
	Nm/A	0.46	0.93	1.64	1.90	0.46	0.93	1.64	1.90	0.95	1.64	1.90
Continuous Current Rating	(Greased) A	12.9	6.5	3.5	3.0	20.5	10.7	6.0	5.3	14.2	8.1	7.1
	(Oil Cooled) A	25.9	12.9	7.1	6.0	40.9	21.4	12.1	10.6	28.5	16.2	14.2
Peak Current Rating	A	25.9	12.9	7.1	6.0	40.9	21.4	12.1	10.6	28.5	16.2	14.2
O-PK SINUSOIDAL COMMUTATION												
Continuous Motor Torque	lbf-in	47.5	47.5	45.9	45.4	75.1	78.6	78.7	79.5	106.9	105.3	106.9
	Nm	5.37	5.36	5.19	5.13	8.49	8.89	8.89	8.99	12.08	11.90	12.08
Torque Constant (Kt) (+/- 10% @ 25°C)	lbf-in/A	2.9	5.8	10.3	11.9	2.9	5.8	10.3	11.9	5.9	10.3	11.9
	Nm/A	0.33	0.66	1.16	1.34	0.33	0.66	1.16	1.34	0.67	1.16	1.34
Continuous Current Rating	(Greased) A	18.3	9.1	5.0	4.3	28.9	15.1	8.5	7.5	20.1	11.4	10.1
	(Oil Cooled) A	36.6	18.3	10.0	8.6	57.9	30.3	17.1	15.0	40.3	22.9	20.1
Peak Current Rating	A	36.6	18.3	10.0	8.6	57.9	30.3	17.1	15.0	40.3	22.9	20.1
MOTOR STATOR DATA												
Voltage Constant (Ke) (+/- 10% @ 25°C)	Vrms/Krpm	28.0	56.0	99.3	114.6	28.0	56.0	99.3	114.6	57.3	99.3	114.6
	Vpk/Krpm	39.6	79.2	140.5	162.1	39.6	79.2	140.5	162.1	81.0	140.5	162.1
Pole Configuration		8	8	8	8	8	8	8	8	8	8	8
Resistance (L-L)(+/- 5% @ 25°C)	Ohms	0.42	1.7	5.7	7.8	0.2	0.72	2.26	3.0	0.5	1.52	2.0
Inductance (L-L)(+/- 15%)	mH	3.0	11.9	37.5	49.9	1.2	5.4	18.2	23.1	4.0	12.0	16.0
Brake Inertia	lbf-in-sec ²	0.00096										
	Kg-cm ²	1.08										
Brake Current @ 24 VDC	A	0.67										
Brake Holding Torque (Min)	lbf-in	97										
	Nm	11										
Brake Engage/Disengage Time	ms	20/29										
Mechanical Time Constant (tm), ms	min	4.5	4.5	4.8	4.9	2.1	1.9	1.9	1.9	1.2	1.3	1.2
	max	6.0	6.0	6.4	6.6	2.8	2.6	2.6	2.5	1.7	1.7	1.7
Electrical Time Constant (te)	ms	7.0	7.0	6.6	6.4	5.9	7.5	8.0	7.8	8.2	7.9	8.2
Insulation Class		180 (H)										

*Refer to performance specifications on page 8 for availability of 3 stack stator by stroke/lead combination.
Test data derived using NEMA recommended aluminum heatsink 12" x 12" x 1/2" at 25°C ambient.

Specifications subject to change without notice.

GSX Series Integrated Motor/Actuator

GSX50

Motor Stator		138	158	168	238	258	268	338	358	368
Bus Voltage	Vrms	230	400	460	230	400	460	230	400	460
Speed @ Bus Voltage	rpm	2400								
RMS SINUSOIDAL COMMUTATION										
Continuous Motor Torque	lbf-in	107.2	104.8	109.4	179.9	178.8	177.8	233.3	237.2	238.3
	Nm	12.12	11.84	12.36	20.32	20.20	20.09	26.36	26.80	26.93
Torque Constant (Kt) (+/- 10% @ 25°C)	lbf-in/A	11.8	20.2	23.6	11.8	20.2	23.6	12.0	20.2	24.0
	Nm/A	1.33	2.28	2.67	1.33	2.28	2.67	1.36	2.28	2.71
Continuous Current Rating	(Greased) A	10.2	5.8	5.2	17.0	9.9	8.4	21.7	13.1	11.1
	(Oil Cooled) A	20.3	11.6	10.4	34.1	19.8	16.8	43.4	26.2	22.2
Peak Current Rating	A	20.3	11.6	10.4	34.1	19.8	16.8	43.4	26.2	22.2
O-PK SINUSOIDAL COMMUTATION										
Continuous Motor Torque	lbf-in	107.2	104.8	109.4	179.9	178.8	177.8	233.3	237.2	238.3
	Nm	12.12	11.84	12.36	20.32	20.20	20.09	26.36	26.80	26.93
Torque Constant (Kt) (+/- 10% @ 25°C)	lbf-in/A	8.3	14.3	16.7	8.3	14.3	16.7	8.5	14.3	17.0
	Nm/A	0.94	1.62	1.88	0.94	1.62	1.88	0.96	1.62	1.92
Continuous Current Rating	(Greased) A	14.4	8.2	7.3	24.1	14.0	11.9	30.7	18.5	15.7
	(Oil Cooled) A	28.7	216.4	14.7	48.2	27.9	23.8	61.4	37.1	31.4
Peak Current Rating	A	28.7	16.4	14.7	48.2	27.9	23.8	61.4	37.1	31.4
MOTOR STATOR DATA										
Voltage Constant (Ke) (+/- 10% @ 25°C)	Vrms/Krpm	80.6	138.1	161.1	80.6	138.1	161.1	82.0	138.1	164.0
	Vpk/Krpm	113.9	195.3	227.9	113.9	195.3	227.9	116.0	195.3	232.0
Pole Configuration		8	8	8	8	8	8	8	8	8
Resistance (L-L)(+/- 5% @ 25°C)	Ohms	0.87	2.68	3.34	0.34	1.01	1.39	0.22	0.61	0.86
Inductance (L-L)(+/- 15%)	mH	21.7	63.9	78.3	8.9	27.6	41.5	6.3	17.8	28.2
Brake Inertia	lbf-in-sec ²	0.0084								
	Kg-cm ²	9.5								
Brake Current @ 24 VDC	A	1								
Brake Holding Torque (Min)	lbf-in	354								
	Nm	40								
Brake Engage/Disengage Time	ms	25/73								
Mechanical Time Constant (tm), ms	min	2.2	2.3	2.1	0.9	0.9	0.9	0.5	0.5	0.5
	max	2.8	3.0	2.7	1.1	1.1	1.1	0.7	0.7	0.7
Electrical Time Constant (te)	ms	25.0	23.9	23.4	26.1	27.3	29.9	28.0	29.0	32.9
Insulation Class		180 (H)								

Test data derived using NEMA recommended aluminum heatsink 12" x 12" x 1/2" at 25°C ambient

Specifications subject to change without notice.

GSX Series Integrated Motor/Actuator

GSX60

Motor Stator		138	158	168	238	258	268	358	368
Bus Voltage	Vrms	230	400	460	230	400	460	400	460
Speed @ Bus Voltage	rpm	2400							
RMS SINUSOIDAL COMMUTATION									
Continuous Motor Torque	lbf-in	254.2	249.9	261.9	424.8	423.0	427.5	595.6	615.0
	Nm	28.72	28.23	29.59	47.99	47.79	48.30	67.29	69.49
Torque Constant (Kt) (+/- 10% @ 25°C)	lbf-in/A	12.6	21.8	25.2	12.6	21.8	25.2	21.4	25.2
	Nm/A	1.42	2.46	2.84	1.42	2.46	2.84	2.42	2.84
Continuous Current Rating	(Greased) A	22.6	12.8	11.6	37.7	21.7	19.0	31.1	27.3
	(Oil Cooled) A	45.2	25.6	23.3	75.5	43.4	38.0	62.2	54.6
Peak Current Rating	A	45.2	25.6	23.3	75.5	43.4	38.0	62.2	54.6
O-PK SINUSOIDAL COMMUTATION									
Continuous Motor Torque	lbf-in	254.2	249.9	261.9	424.8	423.0	427.5	595.6	611.6
	(Nm)	28.72	28.23	29.59	47.99	47.79	48.30	67.29	69.10
Torque Constant (Kt) (+/- 10% @ 25°C)	lbf-in/A	8.9	15.4	17.8	8.9	15.4	17.8	15.1	17.8
	Nm/A	1.01	1.74	2.01	1.01	1.74	2.01	1.71	2.01
Continuous Current Rating	(Greased) A	31.9	18.1	16.4	53.4	30.7	26.8	44.0	38.4
	(Oil Cooled) A	63.9	36.2	32.9	106.7	61.3	53.7	88.0	76.8
Peak Current Rating	A	63.9	36.2	32.9	106.7	61.3	53.7	88.0	76.8
MOTOR STATOR DATA									
Voltage Constant (Ke) (+/- 10% @ 25°C)	Vrms/Krpm	85.9	148.9	171.8	85.9	148.9	171.8	146.1	171.8
	Vpk/Krpm	121.5	210.6	243.0	121.5	210.6	243.0	206.6	243.0
Pole Configuration		8	8	8	8	8	8	8	8
Resistance (L-L)(+/- 5% @ 25°C)	Ohms	0.3	1.0	1.2	0.13	0.41	0.5	0.23	0.3
Inductance (L-L)(+/- 15%)	mH	8.3	24.8	29.4	3.9	11.8	15.8	7.5	10.3
Brake Inertia	lbf-in-sec ²	0.02815							
	Kg-cm ²	31.8							
Brake Current @ 24 VDC	A	1.45							
Brake Holding Torque (Min)	lbf-in	708							
	Nm	80							
Brake Engage/Disengage Time	ms	53/97							
Mechanical Time Constant (tm), ms	min	3.9	4.0	3.6	1.6	1.6	1.6	1.0	0.9
	max	4.3	4.5	4.1	1.8	1.8	1.8	1.1	1.0
Electrical Time Constant (te)	ms	25.4	24.6	24.0	29.4	29.1	29.8	32.1	33.8
Insulation Class		180 (H)							

Test data derived using NEMA recommended aluminum heatsink 16" x 16" x 1" at 25°C ambient
The GSX60-06 can only accommodate a single stack stator.

Specifications subject to change without notice.

GSX Series Integrated Motor/Actuator

Estimated Service Life

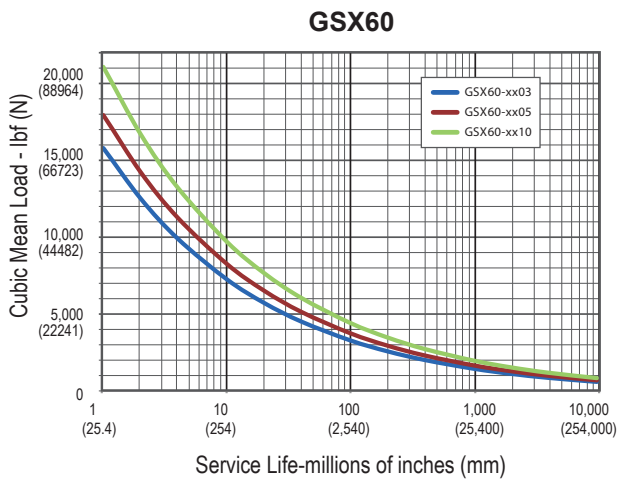
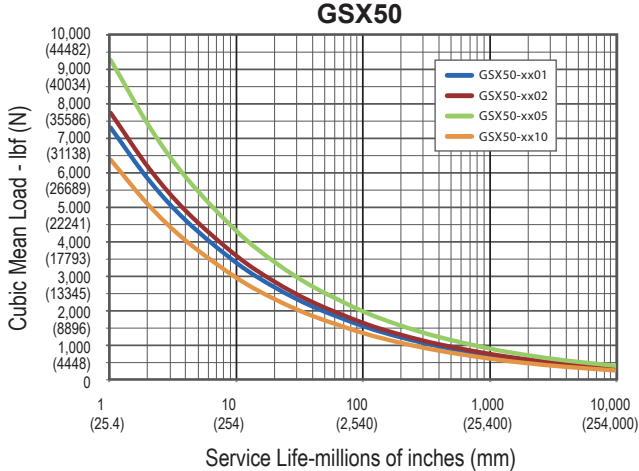
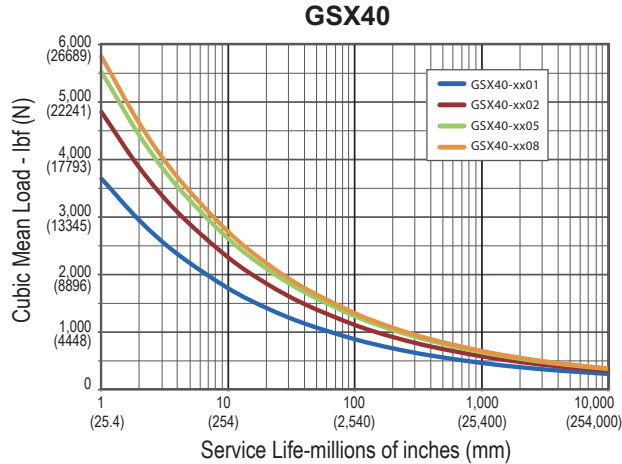
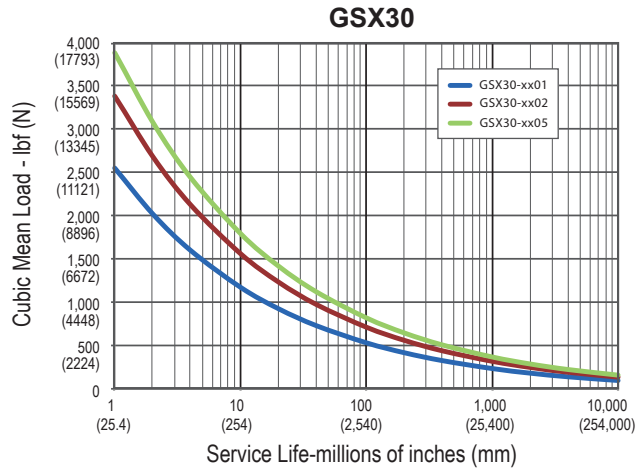
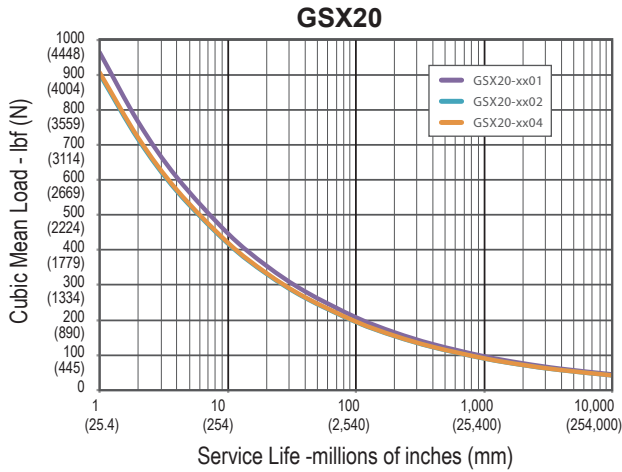

The L_{10} expected life of a roller screw linear actuator is expressed as the linear travel distance that 90% of properly maintained roller screws manufactured are expected to meet or exceed. This is not a guarantee and these charts should be used for estimation purposes only.

The underlying formula that defines this value is:
Travel life in millions of inches, where:

$$L_{10} = \left(\frac{C_a}{F_{cml}} \right)^3 \times \ell$$

C_a = Dynamic load rating (lbf)
 F_{cml} = Cubic mean applied load (lbf)
 ℓ = Roller screw lead (inches)

For additional details on calculating estimated service life, please refer to the Engineering Reference, page 169.

Service Life Estimate Assumptions:

- Sufficient quality and quantity of lubrication is maintained throughout service life (please refer to engineering reference on page 173 for lubrication interval estimates.)
- Bearing and screw temperature between 20° C and 40° C
- No mechanical hard stops (external or internal) or impact loads
- No external side loads
- Does not apply to short stroke, high frequency applications such as fatigue testing or short stroke, high force applications such as pressing. (For information on calculating estimating life for unique applications please refer to the engineering reference on page 169.)

Speed vs. Force Curves

These charts represent typical linear speed versus linear force curves for the GSX actuators using common brushless motor amplifiers. The GSX Series are compatible with many different brushless motor amplifiers; any differences in the performance

ratings of these amplifiers can alter the actuator's performance. Thus, the curves below should be used for estimation only. (Further information is available by contacting your local sales representative.)

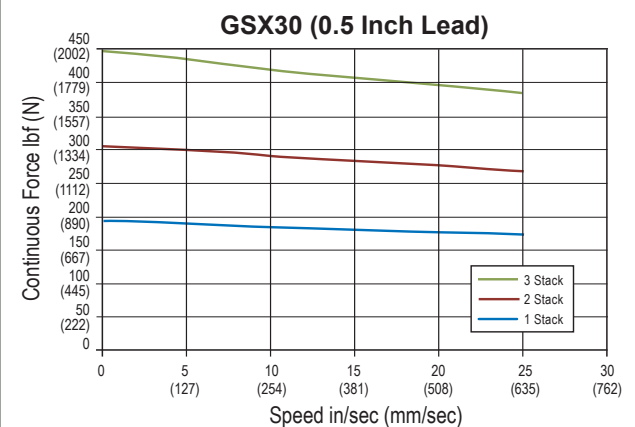
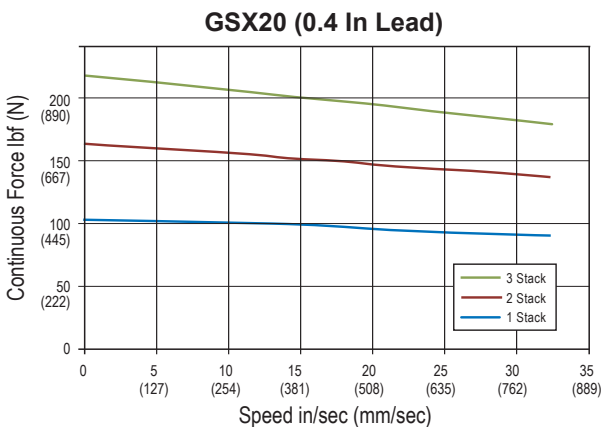
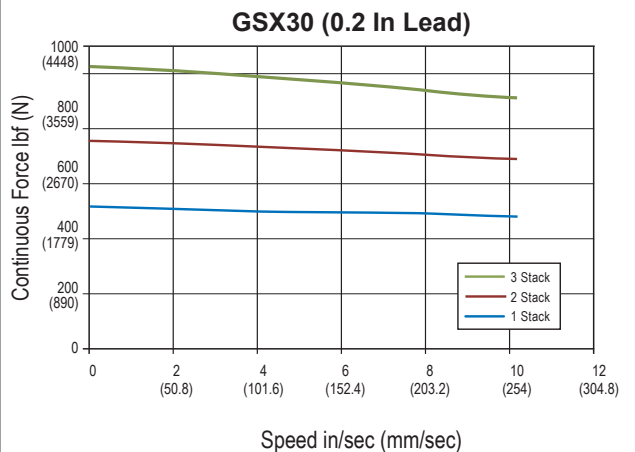
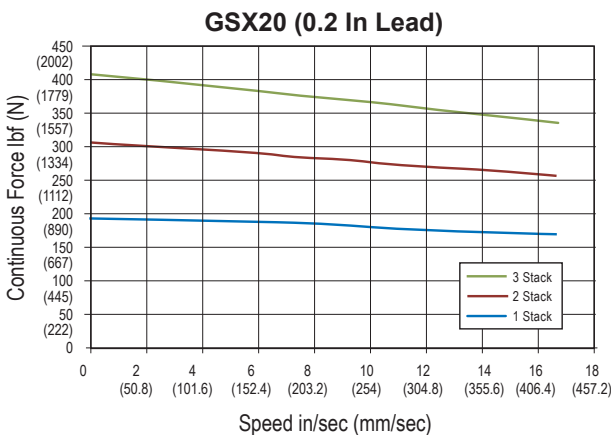
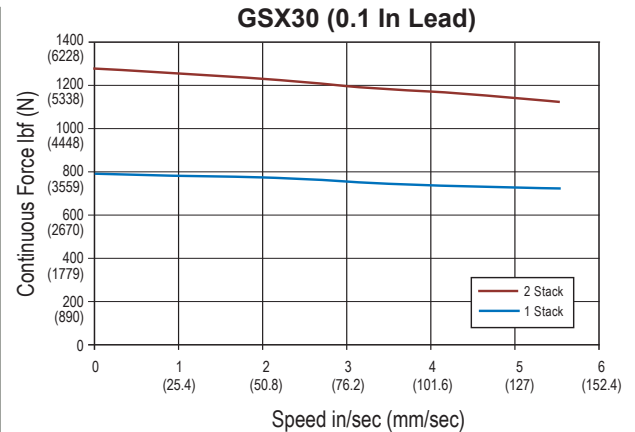
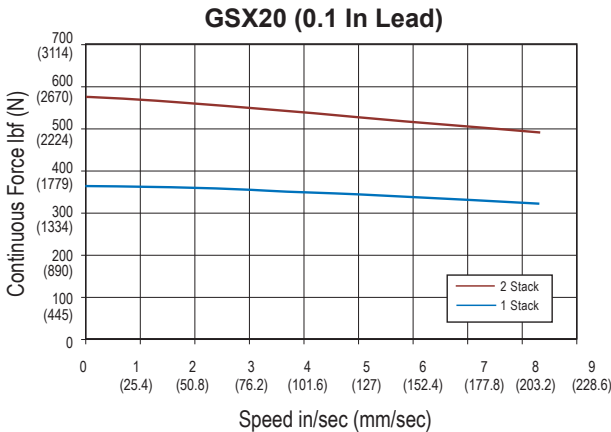

See page 22 for explanation of motor stator options (1x8, 2x8, 3x8)
See page 7 for mechanical specifications

Test data derived using NEMA recommended aluminum heatsink 10" x 10" x 1/4" for GSX20 and 10" x 10" x 3/8" for GSX30. Testing ambient temperature 25°C.

GSX Series Integrated Motor/Actuator

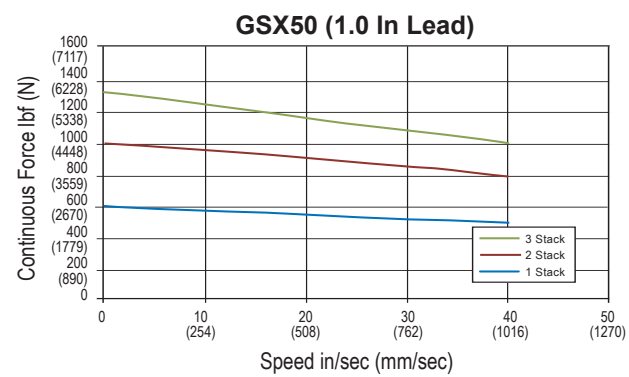
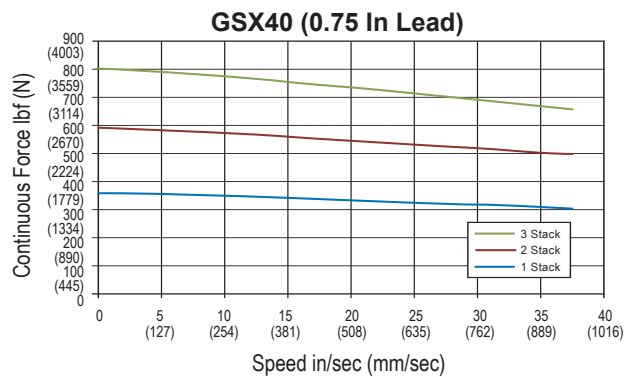
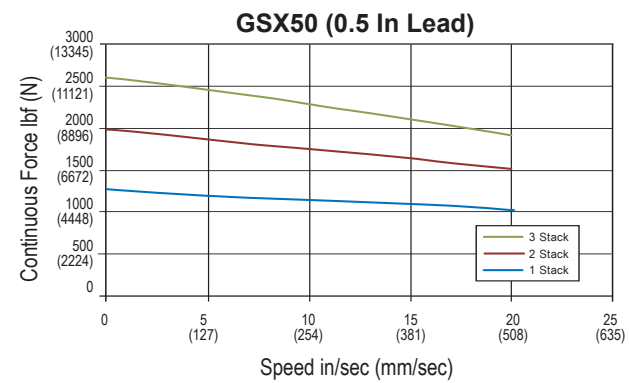
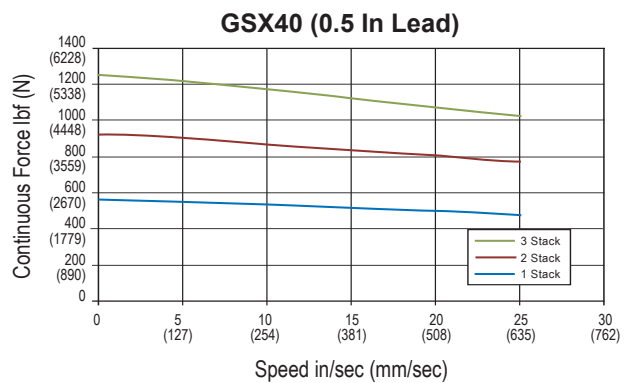
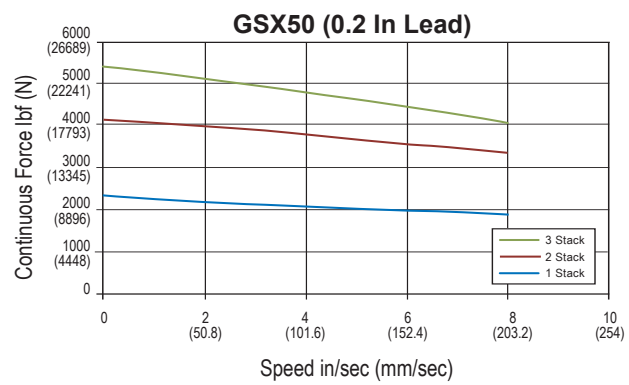
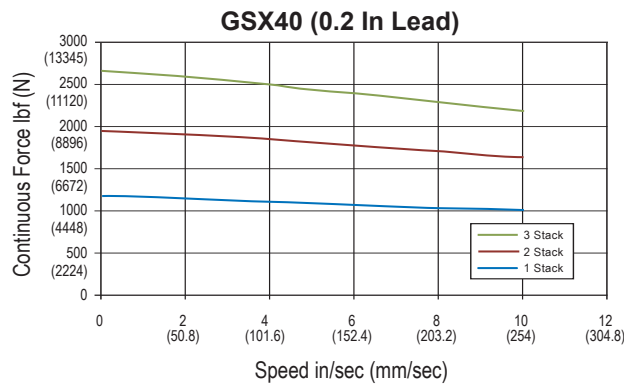
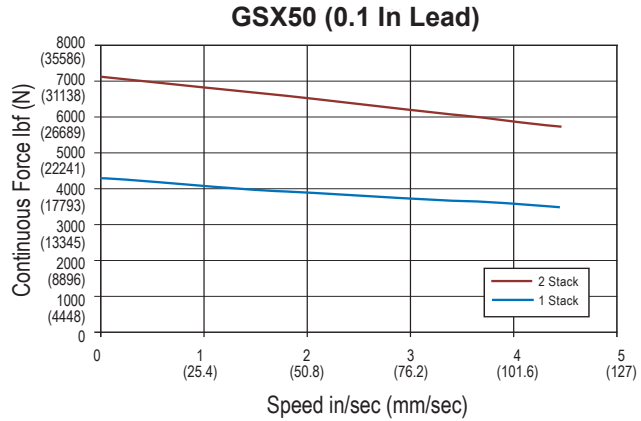
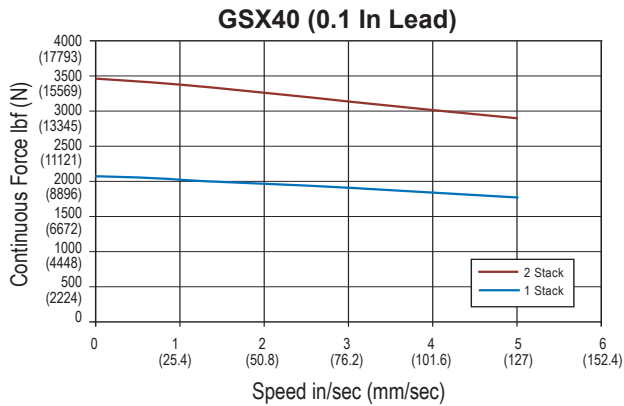

GSX Series Integrated Motor/Actuator

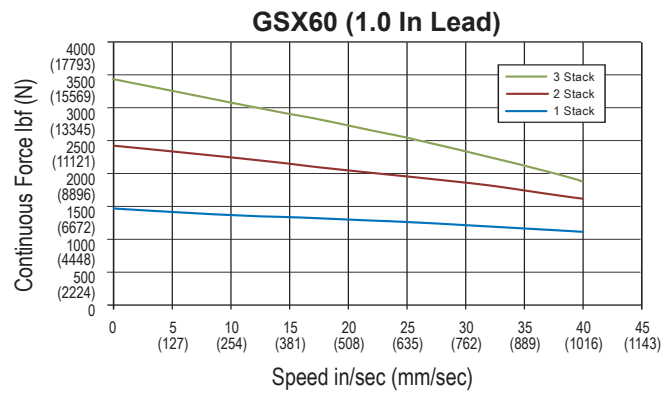
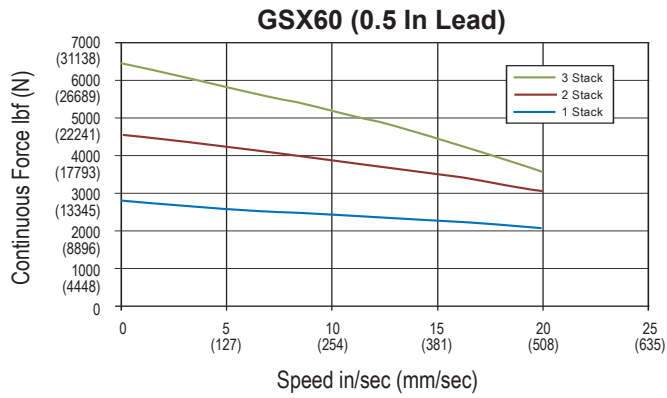
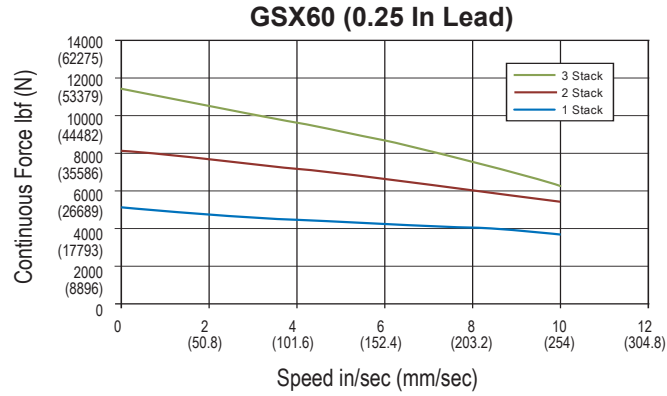

See page 22 for explanation of motor stator options (1x8, 2x8, 3x8)
See page 7 for mechanical specifications

Test data derived using NEMA recommended aluminum heatsink 12" x 12" x 1/2" for GSX40, 12" x 12" x 1/2" for GSX50, and 16" x 16" x 1" for GSX60.
Testing ambient temperature 25°C.

GSX Series Integrated Motor/Actuator

System Configuration

GSX Series actuators include an integrated brushless servo motor. The unique design gives users a variety of feedback configuration options so GSX units can be powered by almost any brushless motor amplifier on the market.

This flexibility means GSX actuators can be incorporated into today's high performance single and multi-axis motion control

systems. For food and beverage packaging, to multi-axis turning centers, to aircraft assembly, the GSX Series units offers incredible performance and durability.

The schematic below shows typical connections for a single axis system with actuator and servo amplifier.

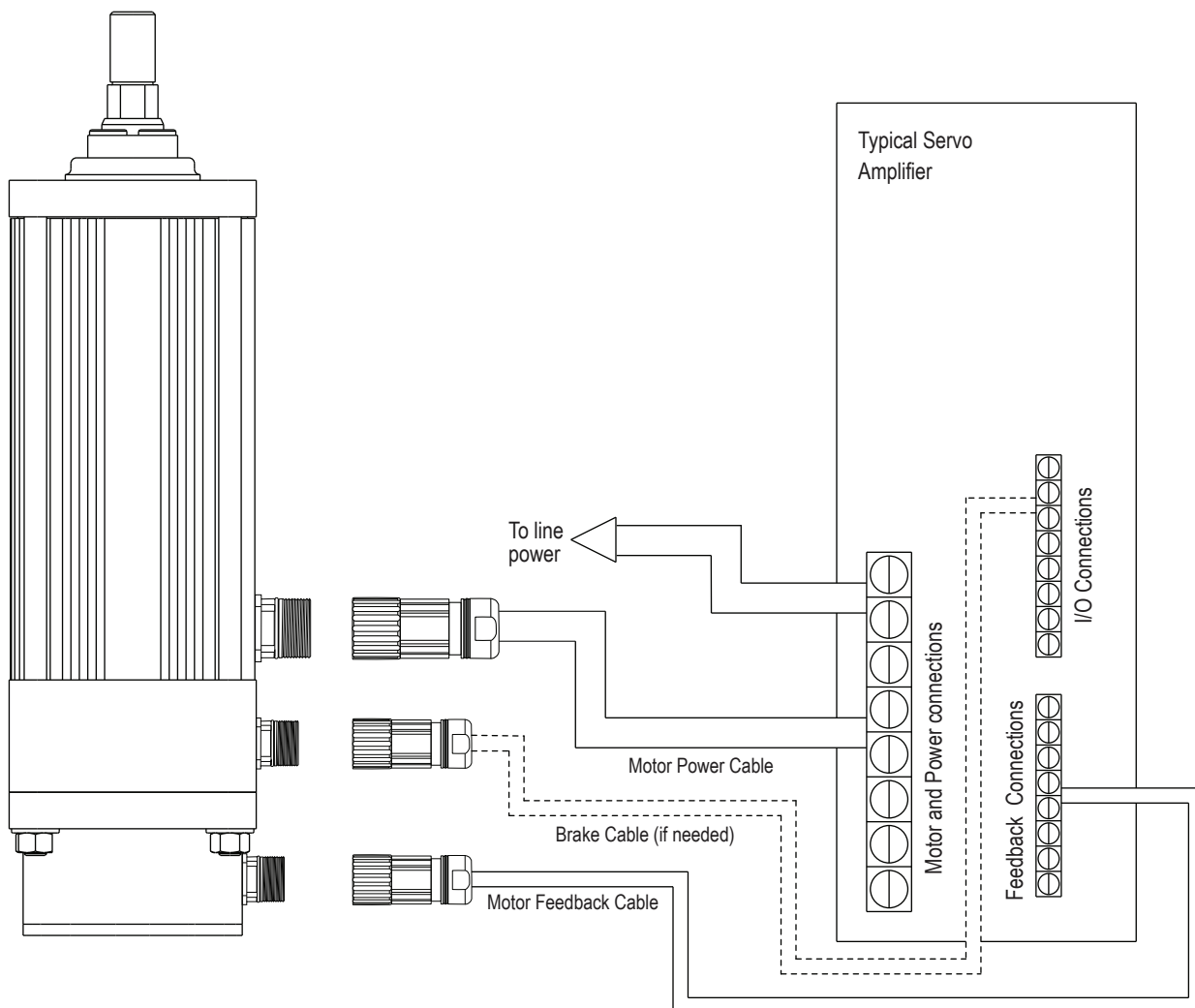

Options

AR = Anti-rotation Option

The unique design of the GSX Series of linear actuators permits the extending rod to rotate. This capability simplifies setup by allowing the user to rotate the rod in and out of the actuator for mechanical attachment or system testing.

However, this feature also requires that once setup and testing are completed, the rod be kept from rotating so proper linear motion will be maintained. In most applications the actuator's load is coupled to linear bearings, or some other support device. In these cases the load cannot rotate, so a separate anti-rotation system is not needed.

For applications in which the load is free to rotate, Exlar offers anti-rotation systems. Shorter GSX units use an anti-rotation arm on one side of the actuator. Longer strokes use arms on both sides.

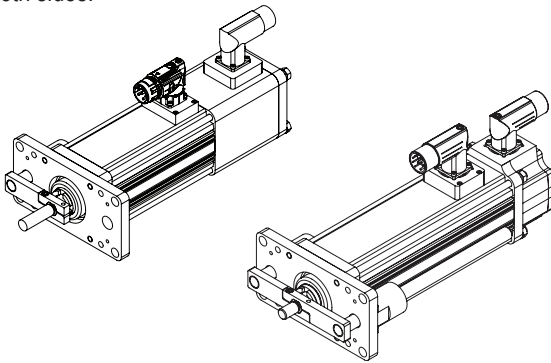

PB = Protective Bellows

This option provides an accordion style protective bellows to protect the main actuator rod from damage due to abrasives or other contaminants in the operating environment. The standard material of this bellows is S2 Neoprene coated nylon with sewn construction. This standard bellows is rated for environmental temperatures of -40 to 250 degrees F. This option requires the main rod of the actuator to be extended beyond standard length. Not available with extended tie rod mounting option. Please contact your local sales representative for details.

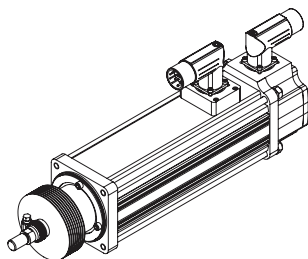

RB = Rear Electric Brake

This option provides an internal holding brake for GSX Series actuators. The brake is spring activated and electrically released.

SR = Splined Main Rod

This option provides a ball spline shafting main rod with a ball spline nut that replaces the standard front seal and bushing assembly. This rod restricts rotation without the need for an external mechanism. The rod diameter will be the closest metric equivalent to our standard rod sizes. Since this option is NOT sealed, it is not suitable for environments in which contaminants may enter the actuator.

Note: This option affects overall length and mounting dimensions for GSX actuators. Consult your local sales representative if using splined main rod. Due to the reduced diameter of the splined main rod on the GSX50, the standard "A", "F", and "B" rod ends are not available and an "X" should be used in the model mask. Please see Actuator Rod Ends with Splined Main Rod Options on page 32 for dimensions.

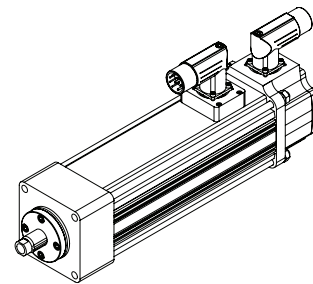

L1, L2, L3 = Adjustable External Travel Switches

This option allows up to 3 external switches to be included with the GSX Series Actuator. These switches provide travel indication to the controller and are adjustable (must purchase external anti-rotate for this option). See page 29 for details.

GSX Series Integrated Motor/Actuator

Motor Speed

All Exlar T-LAM motors and actuators carry a standard motor speed designator (see chart). This is representative of the standard base speed of the motor for the selected bus voltage.

Designator	Base Speed	Actuator/Motor Series
-50	5000 rpm	GSX20
-30	3000 rpm	GSX30, GSX40
-24	2400 rpm	GSX50, GSX60

If the model number is created and the location for the motor speed designator is left blank, this is the base speed to which the motor will be manufactured. The model number can also be created including this standard speed designator.

Feedback

Absolute Feedback

Due to the variability in size of some feedback devices, especially absolute feedback devices which are often very large relative to the size of the actuator motor, the actual size of the actuator may differ in length and width from these drawings for feedback types other than standard resolvers and standard encoders. Please consult Exlar for details. In the event that you order an actuator that differs from these standard dimensions, you will be sent a drawing of the final configuration of your actuator.

Motor Stators

GSX motor options are described with a 3 digit code. The first digit calls out the stack length, the second the rated bus voltage, and the third the number of poles of the motor. Refer to the mechanical/electrical specifications for motor torque and actuator rated force.

118	1 stack	115 Vrms	8 Pole	Class 180 H
138		230 Vrms		
158		400 Vrms		
168	2 stack	460 Vrms	8 Pole	Class 180 H
218		115 Vrms		
238		230 Vrms		
258		400 Vrms		
268	3 stack	460 Vrms	8 Pole	Class 180 H
318		115 Vrms		
338		230 Vrms		
358		400 Vrms		
368		460 Vrms		

* Low voltage stators may be limited to less than catalog rated torque and/or speed. Please contact your local sales representative when ordering this option.

Rod End Attachments

**Rear Clevis Pin
Rod Eye**

**Spherical Rod Eye
Rod Clevis**

See drawings on pages 30-32.

Attachments ordered separate from actuator.

Oil Cooling and Lubrication Option

If you plan to use oil cooling with your GSX actuator, consult your local sales representative to discuss your application.

Exlar GSX actuators are normally delivered with high performance synthetic grease as a lubricant. The application of grease for the roller screw mechanism and bearings has proven adequate in thousands of applications over 25 years. However, in applications where the actuator is operated under high load, high speed and/or high duty cycle for extended periods of time, the grease will degrade prematurely and will eventually fail to provide the lubrication needed to maintain the operating efficiency and integrity of the roller screw and bearings. Continued operation of the actuator after the grease has broken down will cause premature failure of the device.

An ideal way to both lubricate and cool a GSX Series actuator in high performance applications is to flow a small amount of oil at low pressure through the actuator while it is in operation. A small amount of oil flow can, in many cases, allow operation of the actuator beyond normal continuous rated power levels. Oil flow lubrication has been used successfully and extensively in the field, allowing Exlar actuators to deliver thousands of hours of service between re-lubrication intervals even in the most arduous of applications.

Oil lubrication also significantly reduces actuator maintenance, saving valuable production time. With a recirculating oil system, lubricating oil is easily changed without having to access or

dismount the actuator. The ability to monitor oil condition can extend the usable life of the actuator by keeping the lubrication clean and fresh.

Some special application and actuator configuration considerations must be addressed prior to selecting and ordering a GSX actuator with oil lubrication. Please consult with Exlar Application Engineering prior to purchase.

A typical oil flow lubrication system involves use of a commercially available lubrication pump and plumbing to recirculate the oil. A schematic example of a possible oil system is shown below. Exlar Application Engineering can assist you in the development of an appropriate oil system, or recommend a pre-packaged oil circulation system.

If you plan to use oil cooling with your GSX actuator, please consult Exlar to discuss your application.

Oil pressure within the actuator should never exceed 5 psi.

The Oil cooling option will limit maximum actuator acceleration.

Example Oil System Schematic
(Customer Supplied)

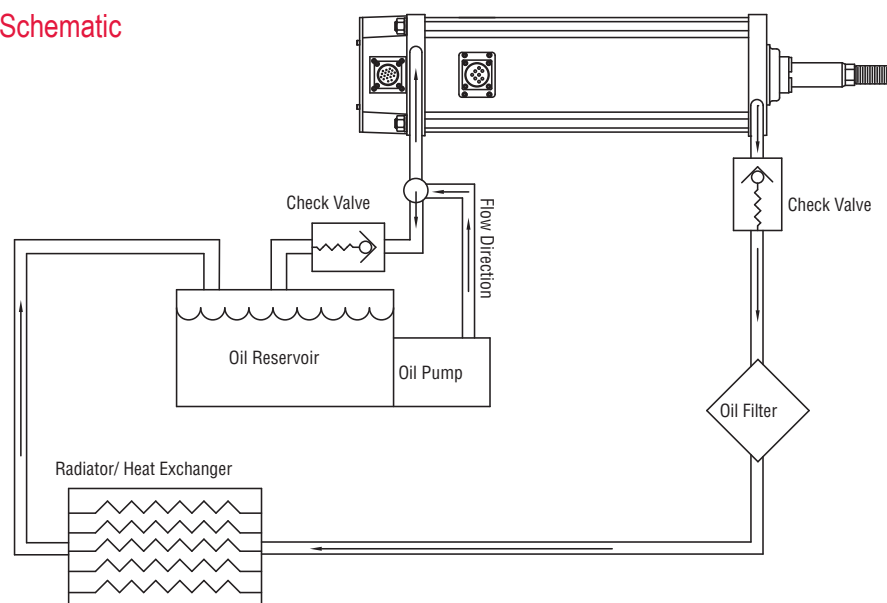

Dimensions Base Actuator

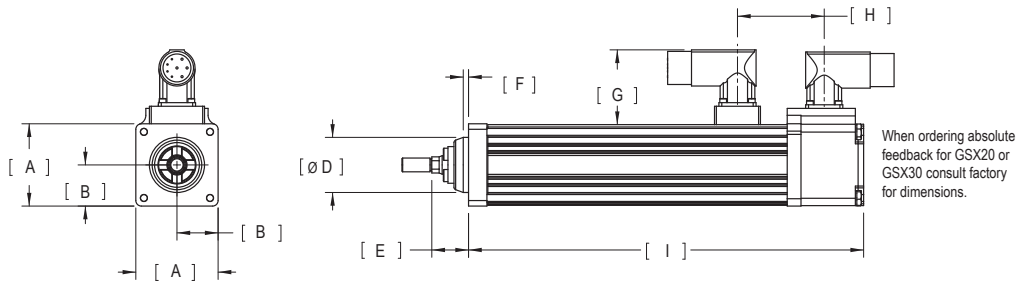

		GSX20	GSX30	GSX40	GSX50	GSX60
A	in	2.24	3.05	3.90	5.50	7.00
	mm	56.9	77.4	99.1	139.7	177.8
B	in	1.12	1.52	1.95	2.75	3.5
	mm	28.4	38.7	49.5	69.9	88.9
Ø D	in	1.500 +0.00/-0.03	2.000 +0.00/-0.03	2.500 +0.00/-0.03	3.000 +0.00/-0.03	3.375 +0.00/-0.03
	mm	38.10 +0.00/-0.08	50.80 +0.00/-0.08	63.50 +0.00/-0.08	76.20 +0.00/-0.08	85.73 +0.00/-0.08
E ⁵	in	1.00	1.32	1.65	2.13	1.94
	mm	25.4	33.5	41.9	54.0	49.4
F	in	0.14	0.09	0.10	0.13	0.13
	mm	3.7	2.3	2.5	3.2	3.2
G	in	2.04	2.04	2.04	2.04	2.04
	mm	51.7	51.7	51.7	51.7	51.7
H ⁴	in	2.36	2.63	2.63	3.09	4.18
	mm	60.0	66.7	66.7	78.6	106.2
I ⁴ (zero stroke)	in	4.8	5.2	6.6	8.3	9.2
	mm	122	133	167	212	235

1. Dimensions shown are for referencing only and are subject to change
2. Dimensions reflect Exlar standard M23 style connectors (option I)
3. Dimensions may vary based on options selected. Consult Exlar for details or refer to drawings provided after receipt of order
4. If ordering a brake, add the following to dimensions H and I:
 GSX20 add 1.78 in (45.2 mm)
 GSX30 add 1.60 in (40.6 mm)
 GSX40 add 2.33 in (59.2 mm)
 GSX50 add 2.50 in (63.5 mm)
 GSX60 add 3.58 in (90.9 mm)
5. If ordering bellows add 2 in (50.8 mm) to dimension E.

Front or Rear Flange Mount

GSX20, GSX50

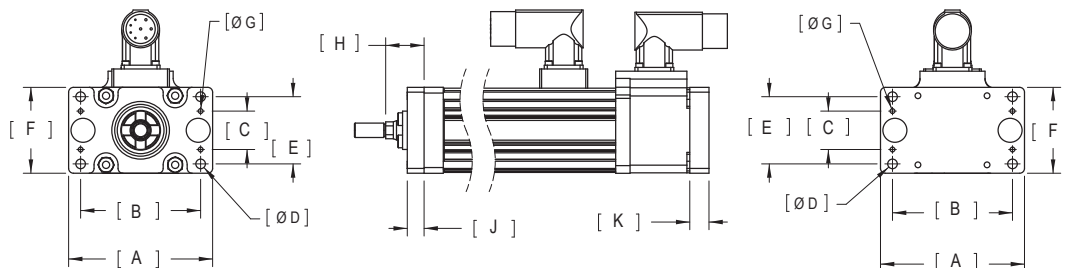

GSX30, GSX40, GSX60

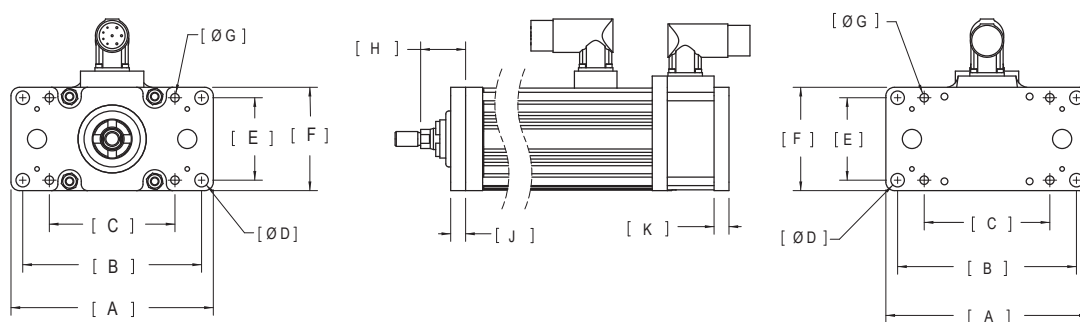

		GSX20	GSX30	GSX40	GSX50	GSX60
A	in	3.75	5.94	7.68	9.50	12.50
	mm	95.3	150.9	195.1	241.3	317.5
B	in	3.13	5.25	6.80	7.63	10.17
	mm	79.4	133.4	172.7	193.7	258.4
C	in	1.00	3.69	5.25	3.25	8.13
	mm	25.4	93.7	133.4	82.6	206.4
Ø D	in	0.250	0.397	0.516	0.563	0.781
	mm	6.35	10.08	13.10	14.29	19.84
E	in	1.75	2.43	2.92	4.88	5.38
	mm	44.5	61.7	74.2	123.8	136.5
F	in	2.24	3.05	3.80	6.50	6.80
	mm	56.8	77.4	96.5	165.1	172.7
Ø G	in	0.125 +0.001/-0.000	0.250 ±0.0005	0.250 ±0.001	0.250 +0.001/-0.000	0.250 +0.0005/-0.0000
	mm	3.18 +0.03/-0.00	6.35 ±0.013	6.35 ±0.025	6.35 +0.03/0.00	6.35 +0.013/0.000
H ¹	in	1.00	1.32	1.65	2.13	1.94
	mm	25.4	33.5	41.9	54.0	49.4
J ¹	in	0.44	0.44	0.63	0.75	0.75
	mm	11.1	11.1	15.9	19.1	19.1
K	in	0.50	0.44	0.63	0.75	1.31
	mm	12.7	11.1	15.9	19.1	33.3

- If ordering a splined main rod, add the following to dimensions H and J:
 GSX20 add .50 in (12.7 mm), GSX30 add 1.20 in (30.5 mm), GSX40 add 1.77 in (45.0 mm)
 GSX50 add 2.06 in (52.3 mm), GSX60 add 2.73 in (69.3 mm)

Pre-sale drawings and models are representative and are subject to change. Certified drawings and models are available for a fee. Consult your local Exlar representative for details.

GSX Series Integrated Motor/Actuator

Side Mount or Extended Tie Rod Mount

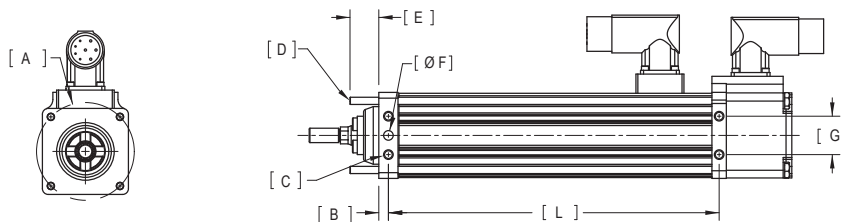

		GSX20	GSX30	GSX40	GSX50	GSX60
Ø A	in	2.546	3.536	4.243	6.125	7.778
	mm	64.66	89.80	107.76	155.58	197.57
B²	in	0.25	0.25	0.31	0.41	0.44
	mm	6.4	6.4	7.9	10.3	11.1
C¹	in	1/4-20 UNC	1/4-20 UNC	3/8-16 UNC	1/2-13 UNC	5/8-11 UNC
	mm	M6 x 1.0	M6 x 1.0	M10 x 1.5	M12 x 1.75	M16 x 2
D	in	10-24 UNC	1/4-20 UNC	3/8-16 UNC	1/2-13 UNC	9/16-12 UNC
	mm	M5 x 0.8	M6 x 1.0	M8 x 1.25	M12 x 1.75	M14 x 2
E	in	0.75	0.96	1.38	1.50	1.65
	mm	19.1	24.4	35.1	38.1	41.9
Ø F	in	0.2500	0.2500	0.3750	0.5000	0.5000
	mm	+0/-0.0005 \downarrow 0.25	+0/-0.0005 \downarrow 0.25	+0/-0.0005 \downarrow 0.44	+0/-0.0005 \downarrow 0.50	+0/-0.0005 \downarrow 0.62
G	in	1.00	1.75	1.75	3.00	3.00
	mm	25.4	44.5	44.5	76.2	76.2
L (zero stroke)	in	2.6	3.1	4.3	5.1	5.9
	mm	67	80	109	130	150

1. Side mount options D and K = 8X for dimension C
2. If ordering a splined main rod, add the following to dimension B:
 GSX20 add .50 in (12.7 mm)
 GSX30 add 1.20 in (30.5 mm)
 GSX40 add 1.77 in (45.0 mm)
 GSX50 add 2.06 in (52.3 mm)
 GSX60 add 2.73 in (69.3 mm)

Pre-sale drawings and models are representative and are subject to change. Certified drawings and models are available for a fee. Consult your local Exlar representative for details.

Side Trunnion Mount of Rear Clevis Mount

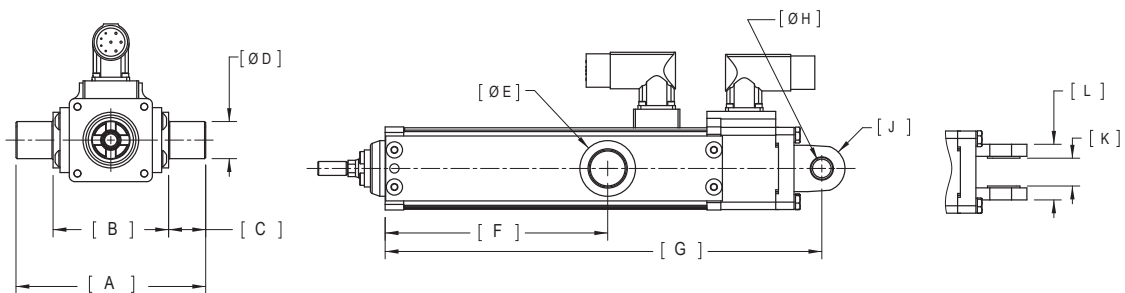

		GSX20	GSX30	GSX40	GSX50	GSX60
A	in	5.12	5.92	6.90	10.00	12.55
	mm	129.9	150.4	175.2	254.0	318.8
B	in	3.12	3.92	4.90	7.00	8.55
	mm	79.1	99.6	124.4	177.8	217.2
C	in	1.00	1.00	1.00	1.50	2.00
	mm	25.4	25.4	25.4	38.1	50.8
Ø D	in	1.000 +/-0.001	1.000 +/-0.001	1.500 +/-0.001	2.000 +/-0.001	2.500 +/-0.001
	mm	25 h7	25 h7	35 h7	50 h7	60 h9
Ø E	in	1.50	1.50	2.00	2.50	3.50
	mm	38.1	38.1	50.8	63.5	88.9
F (3" stroke)	in	3.0	5.4	NA	NA	NA
	mm	76	137	NA	NA	NA
F (4" stroke)	in	NA	NA	4.0	NA	NA
	mm	NA	NA	102	NA	NA
F (6" stroke)	in	6.0	6.0	6.0	6.0	6.0
	mm	152	152	152	152	152
F (8" stroke)	in	NA	NA	8.0	NA	NA
	mm	NA	NA	203	NA	NA
F (10" stroke)	in	10.0	10.0	10.0	10.0	10.0
	mm	254	254	254	254	254
F (12" stroke)	in	12.0	12.0	12.0	NA	NA
	mm	305	305	305	NA	NA
F (14" stroke)	in	NA	14.0	NA	14.0	NA
	mm	NA	356	NA	356	NA
F (18" stroke)	in	NA	18.0	18.0	NA	NA
	mm	NA	457	457	NA	NA
G ¹ (zero stroke)	in	5.8	6.5	8.3	10.6	12.5
	mm	147	165	210	269	318
Ø H	in	0.500 +0.002/-0.001	0.750 +0.002/-0.001	0.750 +0.002/-0.001	1.000 +0.002/-0.001	1.750 +0.002/-0.001
	mm	12 H9	20 H9	20 H9	25 H9	45 H9
J	in	0.63	0.75	0.75	1.00	2.13
	mm	15.9	19.1	19.1	25.4	54.0
K	in	0.75	1.25	1.25	1.50	2.50
	mm	19.1	31.8	31.8	38.1	63.5
L	in	1.50	2.50	2.50	3.00	5.00
	mm	38.1	63.5	63.5	76.2	127.0

- If ordering a brake, add the following to dimension G:
 GSX20 add 1.78 in (45.2 mm), GSX30 add 1.60 in (40.6 mm), GSX40 add 2.33 in (59.2 mm),
 GSX50 add 2.5 in (63.5 mm), GSX60 add 3.58 in (90.9 mm)

Pre-sale drawings and models are representative and are subject to change. Certified drawings and models are available for a fee. Consult your local Exlar representative for details.

GSX Series Integrated Motor/Actuator

Rear Brake Extension Option

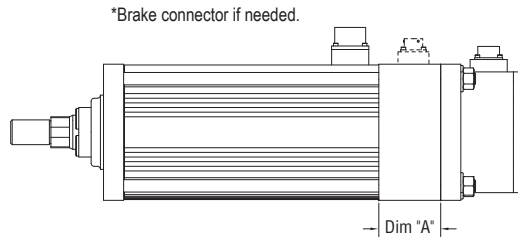

	GSX20	GSX30	GSX40	GSX50	GSX60
A in (mm)	1.78 (45.2)	1.60 (40.6)	2.33 (59.2)	2.50 (63.5)	3.58 (90.9)

*Consult Exlar for connector and wiring information if ordering brake option.

Anti-rotation Option GSX/M20, GSX/M30, GSX/M40 and GSX60

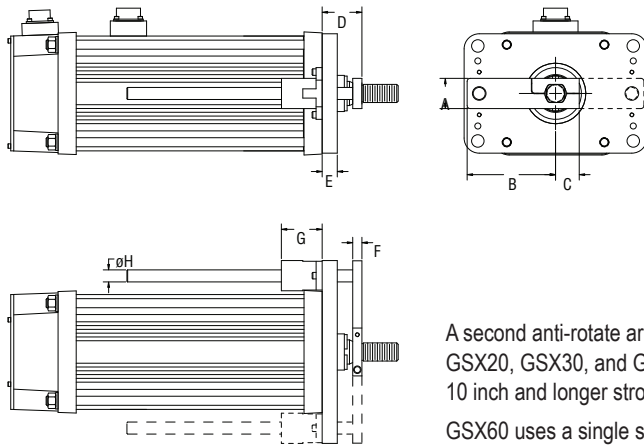

Dims in (mm)	GSX20	GSX30	GSX40	GSX60
A	0.60 (15.2)	0.79 (20.1)	1.25 (31.8)	1.75 (44.5)
B	1.81 (46.0)	2.54 (64.5)	3.78 (96.0)	5.79 (147)
C	0.54 (13.7)	0.71 (18.0)	0.98 (24.9)	1.55 (39.4)
D	1.00 (25.4)	1.30 (33.0)	1.64 (41.7)	1.94 (49.3)
E	0.44 (11.2)	0.44 (11.2)	0.63 (16.0)	0.75 (19.1)
F	0.28 (7.11)	0.32 (8.13)	0.38 (9.65)	0.50 (12.7)
G	0.31 (7.87)	1.69 (42.9)	1.69 (42.9)	2.81 (71.4)
øH	0.37 (9.40)	0.50 (12.7)	0.50 (12.7)	1.00 (25.4)

A second anti-rotate arm is used on GSX20, GSX30, and GSX40 models with 10 inch and longer stroke lengths.

GSX60 uses a single sided anti-rotate for all stroke lengths.

Anti-rotation Option GSX50

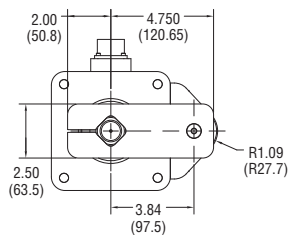

NOTE: GSX50 actuators use one arm for all stroke lengths.

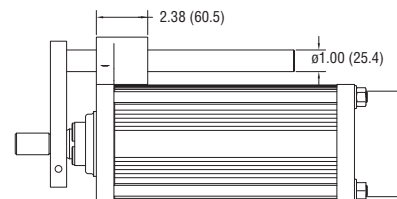
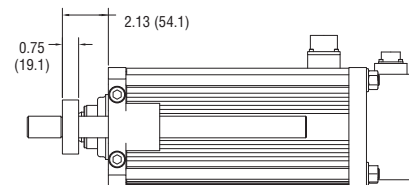

Pre-sale drawings and models are representative and are subject to change. Certified drawings and models are available for a fee. Consult your local Exlar representative for details.

External Limit Switch Option

The external limit switch option (requires anti-rotate option) for the GSX Series of linear actuators provides the user with 1, 2, or 3 externally mounted adjustable switches for use as the end of travel limit switches or home position sensors.

The number of switches desired is selected by ordering the L1, L2, or L3 option, in which 1, 2 or 3 switches will be provided, respectively.

The switches are 9-30 VDC powered, PNP output, with either normally open or normally closed logic operation depending on the switch configuration ordered. Switches are supplied with 1 meter of 3-wire embedded cable. Below is a diagram indicating which logic operation will be provided for each switch, based on the option ordered.

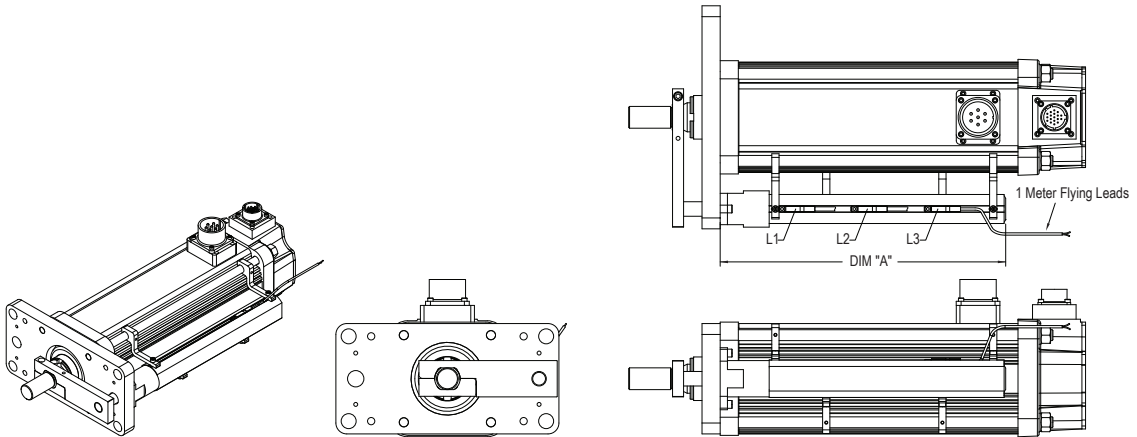

Dim A	3 inch (76 mm) stroke in (mm)	6 inch (152 mm) stroke in (mm)	8 inch (203 mm) stroke in (mm)	10 inch (254 mm) stroke in (mm)	12 inch (305 mm) stroke in (mm)	14 inch (355 mm) stroke in (mm)	18 inch (457 mm) stroke in (mm)
GSX20	5.515 (140.1)	8.515 (216.3)	NA	12.500 (317.5)	14.515 (368.7)	NA	NA
GSX30	6.932 (176.1)	9.832 (249.7)	NA	13.832 (351.3)	15.832 (402.1)	17.832 (452.9)	21.832 (554.5)
GSX40	NA	9.832 (249.7)	11.83 (300.5)	13.832 (351.3)	15.832 (402.1)	NA	21.832 (554.5)
GSX50	NA	11.667 (296.3)	NA	15.667 (397.9)	NA	19.667 (499.5)	NA
GSX60	NA	10.461 (265.7)	NA	14.461 (367.3)	NA	NA	NA

Option	SW1	SW2	SW3
L1	Not Supplied	Normally Open	Not Supplied
L2	Normally Closed	Not Supplied	Normally Closed
L3	Normally Closed	Normally Open	Normally Closed

Switch Type	Exlar Part Number	Turck Part Number
Normally Closed Switch	43404	BIM-UNT-RP6X
Normally Open Switch	43403	BIM-UNT-AP6X

Pre-sale drawings and models are representative and are subject to change. Certified drawings and models are available for a fee. Consult your local Exlar representative for details.

GSX Series Integrated Motor/Actuator

Actuator Rod End Options

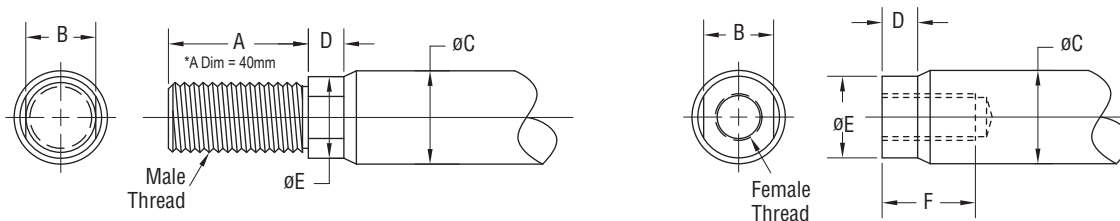

Standard Rod End

	A	B	øC	D	øE	F	Male U.S.	Male Metric	Female U.S.	Female Metric
GSX20 in (mm)	0.813 (20.7)	0.375 (9.5)	0.500 (12.7)	0.200 (5.1)	0.440 (11.2)	0.750 (19.1)	3/8 – 24 UNF – 2A	M8 x 1 6g	5/16 – 24 UNF – 2B	M8 x 1 6H
GSX30 in (mm)	0.750* (19.1)	0.500 (12.7)	0.625 (15.9)	0.281 (7.1)	0.562 (14.3)	0.750 (19.1)	7/16 – 20 UNF – 2A	M12 x 1.75* 6g	7/16 – 20 UNF – 2B	M10 x 1.5 6H
GSX40 in (mm)	1.500 (38.1)	0.750 (19.1)	1.000 (25.4)	0.381 (9.7)	0.875 (22.2)	1.000 (25.4)	3/4 – 16 UNF – 2A	M16 x 1.5 6g	5/8 – 18 UNF – 2B	M16 x 1.5 6H
GSX50 in (mm)	1.625 (41.3)	1.125 (28.6)	1.375 (34.9)	0.750 (19.1)	1.250 (31.8)	1.750 (44.5)	1 – 14 UNS – 2A	M27 x 2 6g	1 – 14 UNS – 2B	M24 x 2 6H
GSX60 in (mm)	2.500 (63.5)	1.250 (31.8)	1.750 (44.5)	0.550 (14.0)	1.625 (41.3)	1.750 (44.5)	1 1/4 – 12 UNF – 2A	M30 x 2 6g	7/8 – 14 UNF – 2B	M25 x 1.5 6H

Rod End with Splined Main Rod

	A	B	C	D	E	F	Male U.S.	Male Metric	Female U.S.	Female Metric
GSX20 in (mm)	0.813 (20.7)	0.375 (9.5)	0.512 (13.0)	0.200 (5.1)	0.440 (11.2)	0.750 (19.1)	3/8 – 24 UNF – 2A	M8 x 1 6g	5/16 – 24 UNF – 2B	M8 x 1 6H
GSX30 in (mm)	0.750* (19.1)	0.500 (12.7)	0.630 (16.0)	0.281 (7.1)	0.562 (14.3)	0.750 (19.1)	7/16 – 20 UNF – 2A	M12 x 1.75* 6g	7/16 – 20 UNF – 2B	M10 x 1.5 6H
GSX40 in (mm)	1.500 (38.1)	0.750 (19.1)	0.906 (23.0)	0.381 (9.7)	0.875 (22.2)	1.000 (25.4)	3/4 – 16 UNF – 2A	M16 x 1.5 6g	5/8 – 18 UNF – 2B	M16 x 1.5 6H
GSX50**** in (mm)	1.625 (41.3)	1.000** (25.4)	1.102 (28.0)	0.750*** (19.1)	1.102 (28.0)	1.500 (38.1)	1 – 14 UNS – 2A	M24 x 2 6g	3/4 – 16 UNF – 2B	M20 x 1.5 6H
GSX60 in (mm)	2.500 (63.5)	1.250 (31.8)	1.850 (47.0)	0.550 (14.0)	1.625 (41.3)	1.750 (44.5)	1 1/4 – 12 UNF – 2A	M30 x 2 6g	7/8 – 14 UNF – 2B	M25 x 1.5 6H

* When Male, Metric (A), Dimension A = 1.575 (40 mm)

** When Male, Metric (A), Dimension B = 0.945 (24 mm)

***When Male (M or A) = 0.500 in (12.7 mm)

****When GSX50 is ordered with a splined rod thread, dimensions are different in accordance with the table.

Part numbers for rod attachment options indicate the through hole size or pin diameter. Before selecting a spherical rod eye please consult the information on the anti-rotation option for the GSX actuators. Spherical rod eyes will allow the rod to rotate if the load is not held.

Pre-sale drawings and models are representative and are subject to change. Certified drawings and models are available for a fee. Consult your local Exlar representative for details.

Rod Clevis

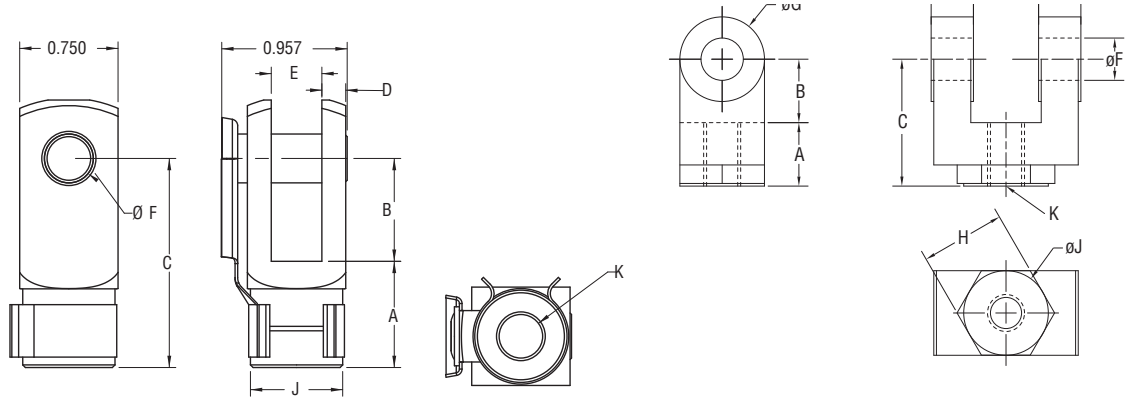

Dimensions for RC038

Dimensions for RC050, RC075, RC100, RC138

	A	B	C	D	E	øF	øG	H	øJ	K
GSX20 RC038 in (mm)	0.810 (20.6)	0.785 (19.9)	1.595 (40.5)	0.182 (4.6)	0.386 (9.8)	0.373 (9.5)	0.951 (24.2)	NA	NA	3/8-24
GSX30 RC050 in (mm)	0.75 (19.1)	0.75 (19.1)	1.50 (38.1)	0.50 (12.7)	0.765 (19.43)	0.50 (12.7)	1.00 (25.4)	1.00 (25.4)	1.00 (25.4)	7/16-20
GSX40 RC075 in (mm)	1.125 (28.58)	1.25 (31.75)	2.375 (60.3)	0.625 (15.88)	1.265 (32.13)	0.75 (19.1)	1.50 (38.1)	1.25 (31.75)	1.25 (31.75)	3/4-16
GSX50 RC100 in (mm)	1.625 (41.2)	1.500 (38.1)	3.125 (79.4)	0.750 (19.1)	1.515 (38.5)	1.000 (25.4)	2.000 (50.8)	1.500 (38.1)	1.500 (38.1)	1-14
GSX60 RC138 in (mm)	2.00 (50.8)	2.125 (53.98)	4.125 (104.78)	1.00 (25.4)	2.032 (51.6)	1.375 (34.93)	2.75 (69.85)	2.00 (50.8)	2.00 (50.8)	1-1/4 - 12

Spherical Rod Eye Dimensions

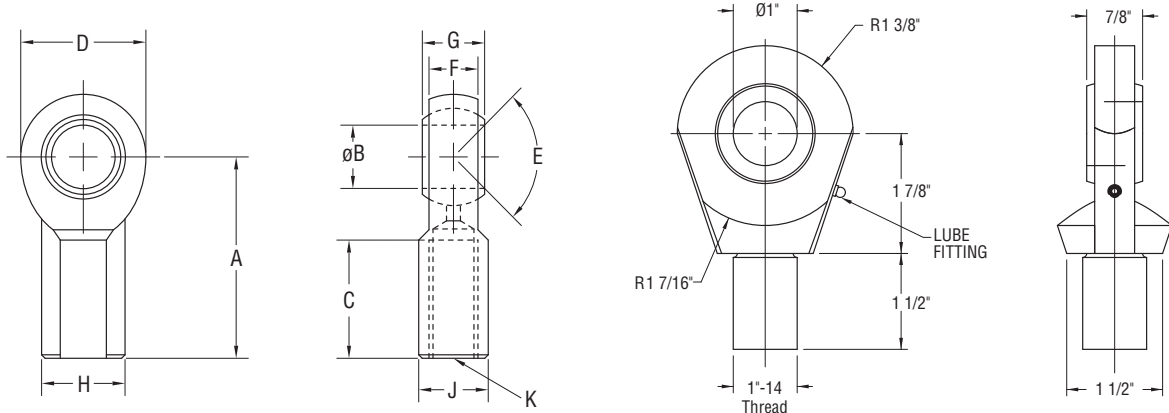

Dimensions for SRM038, SRM044, SRM075

Dimensions for SRF100

	A	øB	C	D	E	F	G	H	J	K
GSX20 SRM038 in (mm)	1.625 (41.3)	.375 (9.525)	.906 (23.0)	1.0 (25.6)	12 deg	.406 (10.3)	.500 (12.7)	.688 (17.7)	.562 (14.3)	3/8-24
GSX30 SRM044 in (mm)	1.81 (46.0)	0.438 (11.13)	1.06 (26.9)	1.13 (28.7)	14 deg	0.44 (11.1)	0.56 (14.2)	0.75 (19.1)	0.63 (16.0)	7/16-20
GSX40 SRM075 in (mm)	2.88 (73.2)	0.75 (19.1)	1.72 (43.7)	1.75 (44.5)	14 deg	0.69 (17.5)	0.88 (22.3)	1.13 (28.7)	1.00 (25.4)	3/4-16
GSX50 SRF100 in (mm)	See GSX50 Special Rod Eye drawing to the right above. Requires female rod end.									

Pre-sale drawings and models are representative and are subject to change. Certified drawings and models are available for a fee. Consult your local Exlar representative for details.

GSX Series Integrated Motor/Actuator

Rod Eye

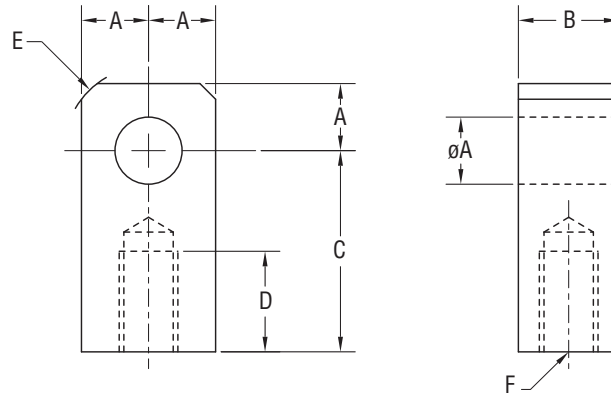

	$\varnothing A$	B	C	D	E	F
GSX20 RE038 in (mm)	0.50 (12.7)	0.560 (14.2)	1.000 (25.4)	0.500 (12.7)	0.25 x 45°	3/8 - 24
GSX30 RE050 in (mm)	0.50 (12.7)	0.75 (19.1)	1.50 (38.1)	0.75 (19.1)	0.63 (15.9)	7/16 - 20
GSX40 RE075 in (mm)	0.75 (19.1)	1.25 (31.8)	2.06 (52.3)	1.13 (28.7)	0.88 (22.3)	3/4 - 16
GSX50 RE100 in (mm)	1.00 (25.4)	1.50 (38.1)	2.81 (71.4)	1.63 (41.4)	1.19 (30.2)	1 - 14
GSX60 RE138 in (mm)	1.375 (34.93)	2.0 (50.8)	3.44 (87.3)	2.0 (50.8)	1.837 (46.67)	1 1/4 - 12

Clevis Pin Dimensions

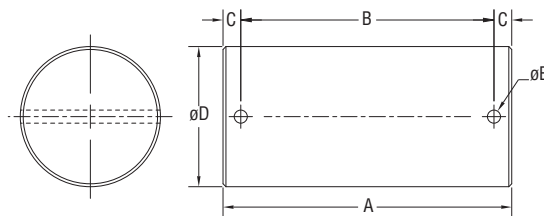

	A	B	C	$\varnothing D$	$\varnothing E$
CP050 ¹ in (mm)	2.28 (57.9)	1.94 (49.28)	0.17 (4.32)	0.50 ^{-0.001/-0.002} (12.7 mm +0.00/-0.05)	0.106 (2.69)
CP075 ² in (mm)	3.09 (78.5)	2.72 (69.1)	0.19 (4.82)	0.75 ^{-0.001/-0.002} (19.1 mm +0.00/-0.05)	0.14 (3.56)
CP100 ³ in (mm)	3.59 (91.2)	3.22 (81.8)	0.19 (4.82)	1.00 ^{-0.001/-0.002} (25.4 mm +0.00/-0.05)	0.14 (3.56)
CP138 ⁴ in (mm)	4.66 (118.3)	4.25 (108)	0.20 (5.08)	1.375 ^{-0.001/-0.002} (34.93 mm +0.00/-0.05)	0.173 (4.39)
CP175 ⁵ in (mm)	5.656 (143.6)	5.25 (133.3)	0.203 (5.15)	1.750 ^{-0.001/-0.002} (44.4 mm +0.00/-0.05)	0.173 (4.39)

¹ Fits GSX20 and GSX30 rear clevis, RCI050 and REI050

² Fits GSX30, 40 and RC075, RE075 and SMR075

³ Fits GSX50 rear clevis, RC100, RE100

⁴ Fits RC138, RE138

⁵ Fits GSX60 rear clevis

Pre-sale drawings and models are representative and are subject to change. Certified drawings and models are available for a fee. Consult your local Exlar representative for details.

[Return to Table of Contents](#)

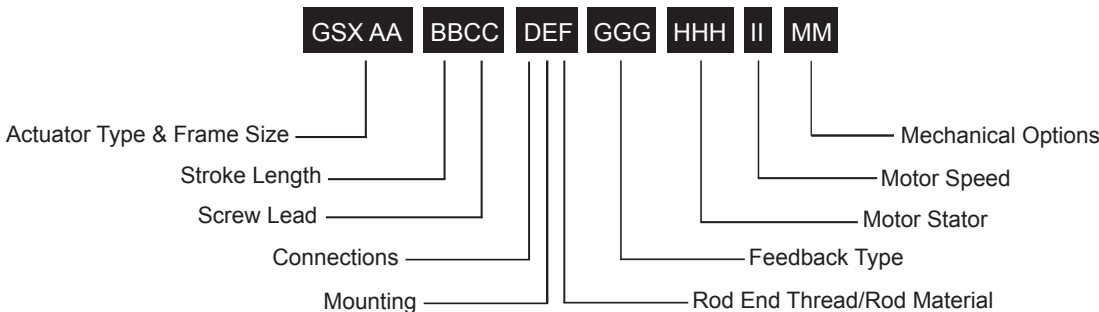

AA = GSX Actuator Frame Size (Nominal)

- 20 = 2 in (50.8 mm)
- 30 = 3 in (76.2 mm)
- 40 = 4 in (101.6 mm)
- 50 = 5.5 in (139.7 mm)
- 60 = 7 in (177.8 mm)

BB = Stroke Length

- 03 = 3 in (76 mm) GSX20, GSX30
- 04 = 4 in (102 mm) GSX40
- 06 = 5.9 in (150 mm) GSX30; 6 in (152 mm) GSX20, GSX40, GSX50, GSX60
- 08 = 8 in (203 mm) GSX40
- 10 = 10 in (254 mm) all models
- 12 = 12 in (305 mm) GSX20, GSX30, GSX40
- 14 = 14 in (356 mm) GSX30, GSX50
- 18 = 18 in (457 mm) GSX30, GSX40

CC = Screw Lead

- 01 = 0.1 in (2.54 mm) (GSX20, GSX30, GSX40, GSX50)⁹
- 02 = 0.2 in (5.08 mm) (GSX20, GSX30, GSX40, GSX50)
- 03 = 0.25 in (6.35 mm) (GSX60)
- 04 = 0.4 in (10.16 mm) (GSX20 only)
- 05 = 0.5 in (12.7 mm) (GSX30, GSX40, GSX50, GSX60)
- 08 = 0.75 in (19.05 mm) (GSX40)⁵
- 10 = 1.0 in (25.4 mm) (GSX50, GSX60)⁶

D = Connections

- I = Exlar standard M23 style⁷
- M = Manufacturer's connector³

E = Mounting

- C = Rear clevis
- F = Front flange
- R = Rear flange
- D = Double side mount¹³
- T = Side trunnion
- E = Extended tie rods
- K = Metric double side mount¹³
- Q = Metric side trunnion
- M = Metric extended tie rods
- G = Metric rear clevis

F = Rod End Thread / Rod Material

- M = Male, US standard thread
- A = Male, metric thread
- F = Female, US standard thread
- B = Female, metric thread

GGG = Feedback Type

See page 164 for detailed information.

HHH = Motor Stator – 8 Pole¹ Class 180H¹²

- 118 = 1 stack, 115 Vrms
- 138 = 1 stack, 230 Vrms
- 158 = 1 stack, 400 Vrms
- 168 = 1 stack, 460 Vrms
- 218 = 2 stack, 115 Vrms
- 238 = 2 stack, 230 Vrms
- 258 = 2 stack, 400 Vrms
- 268 = 2 stack, 460 Vrms
- 318 = 3 stack, 115 Vrms
- 338 = 3 stack, 230 Vrms
- 358 = 3 stack, 400 Vrms
- 368 = 3 stack, 460 Vrms

II = Motor Speed

- 24 = 2400 rpm, GSX50, GSX60
- 30 = 3000 rpm, GSX30, GSX40
- 50 = 5000 rpm, GSX20

MM = Mechanical Options¹⁵

- AR = External anti-rotate assembly¹¹
- RB = Rear electric brake²
- PB = Protective bellows¹⁰
- SR = Splined main rod^{8, 12, 14}
- L1/L2/L3 = External limit switches⁴

NOTES:

1. Stator voltage and pole options allow for catalog rated performance at varying amplifier bus voltages and pole configuration requirements. Refer to performance specification on pages 7-9 for availability of 3 stack stator.
2. The brake option may require a third cable, consult local sales representative.
3. Available as described in Feedback Types.
4. Requires AR option.
5. 0.75 lead not available above 12 inch.
6. 1.0 lead not available above 10 inch stroke.
7. GSX60 uses M40 size 1.5 power connector.
8. If not otherwise specified by the customer, an M24X2 male rod end will be used on the GSX50. See note on page 30.
9. 0.1 lead not available over 10" stroke on GSX50.
10. N/A with extended tie rod mounting option.
11. A second anti-rotate arm is used on GSX20, 30 and 40 for 10 inch and longer stroke.
12. See page 22 for optimized stator offerings.
13. Anti-rotate with D or K mount N/A on 10 inch or longer stroke except in GSX50.
14. Not available in Stainless Steel.
15. For extended temperature operation consult factory for model number.

For cables and accessories, see page 160.



For options or specials not listed above or for extended temperature operation, please contact Exlar

[Return to Table of Contents](#)

TRITEX II® SERIES

FULLY INTEGRATED SERVO DRIVE/MOTOR/ACTUATOR

Linear or Rotary configurations

AC or DC powered models

Multiple networking options

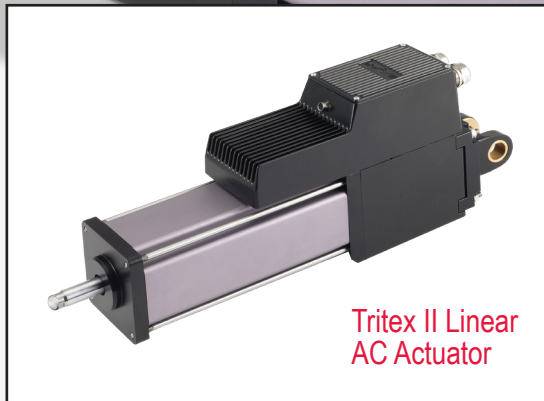
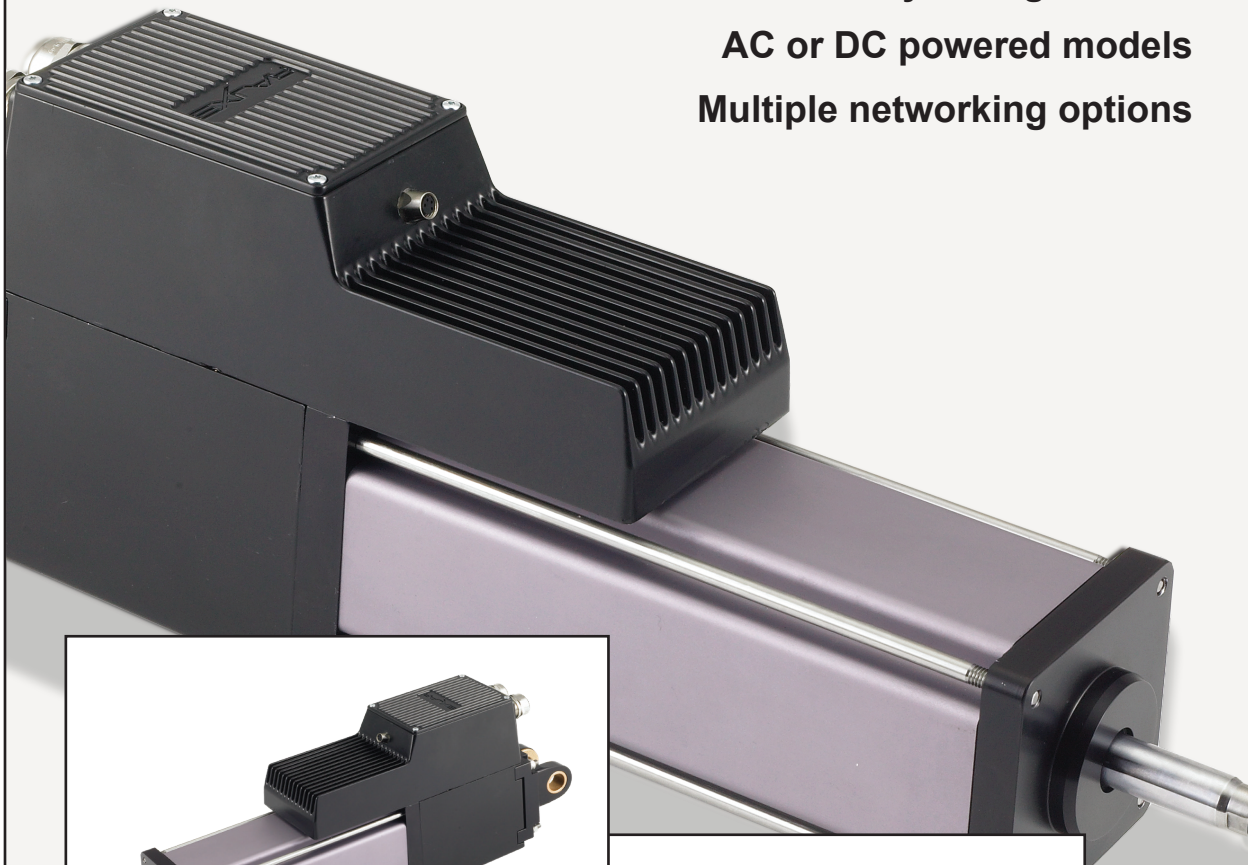

Tritex II Linear
AC Actuator

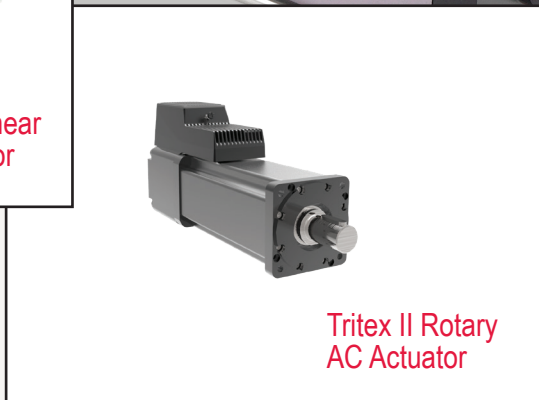

Tritex II Rotary
AC Actuator

Tritex® Series

Fully Integrated Drive/Motor/Actuator

By combining the latest electronic power technology with advanced thermal management modeling technology, Exlar® has set a new benchmark for electric actuator performance versus size. Tritex II actuators now integrate an AC or DC powered servo drive, digital position controller, brushless motor and linear or rotary actuator in one elegant, compact, sealed package. Now you can distribute motion control and resolve your application challenges with one integrated device. Simply connect power, I/O, communications and go!

Dramatically Reduce Space Requirements

Tritex II actuators are the highest power density, smallest footprint servo drive devices on the market. Finally, you can incorporate a fully electronic solution in the space of your existing hydraulic or pneumatic cylinder. You can also eliminate troublesome ball screw actuators or bulky servo gear reducers. And the space previously consumed by panel mount servo drives and motion controllers is no longer needed. Tritex II actuators may also reduce the size of your machine design while significantly improving reliability.

Reduce Costs

Now you can eliminate the labor costs for mounting and wiring panels because the Tritex II houses the servo drive, digital positioner, and actuator in one convenient package. Cable costs are also significantly reduced by eliminating the need for expensive, high-maintenance specialty servo cables. All that is required is an economical standard AC or DC power cord, and standard communication cable for digital and analog I/O.

These actuators also eliminate the issues associated with power signals and feedback signals traveling long distances from servo drive to servo motor. With the Tritex II, the servo drive and motor are always integrated in the same housing.

Flexible Communications

Multiple feedback types, including absolute feedback, allow you to select the system that is best-suited for your application. Digital and analog I/O, plus popular communication networks, such as Modbus TCP, Ethernet/IP, and PROFINET IO, allow the Tritex II to become an integral part of your control architecture or machine control processes.

Improves Power, Performance, and Reliability

Tritex II actuators give you unrivaled power, performance, and reliability. No longer are you limited to trivial amounts of force or speeds so slow that many motion applications are not possible.

Tritex II AC Actuator

- Continuous force to 3225 lbf (14kN)
- Peak force to 5400 lbf (24kN)
- Speed to 33 in/sec (800 mm/sec)
- 1.5 kW servo amplifier
- Temperature operation range -40°C to +65°C
- AC power 100V – 240V, +/-10%

Tritex II DC Actuator

- Continuous force to 872 lbf (4kN)
- Peak force to 1190 lbf (5kN)
- Speed to 33 in/sec (800 mm/sec)
- 750W servo amplifier
- Temperature operation range -40°C to +65°C
- DC power 12-48 VDC nominal

Tritex II System

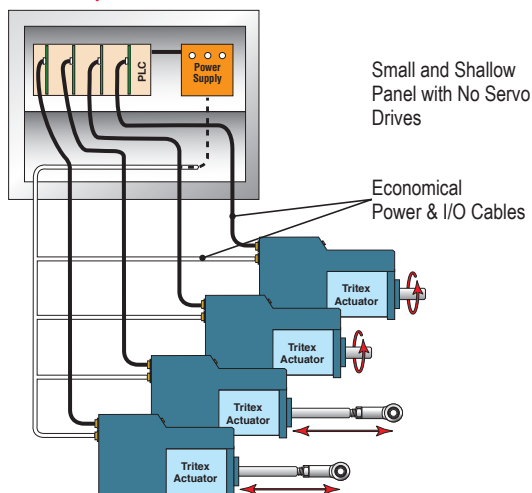

Alternative Systems

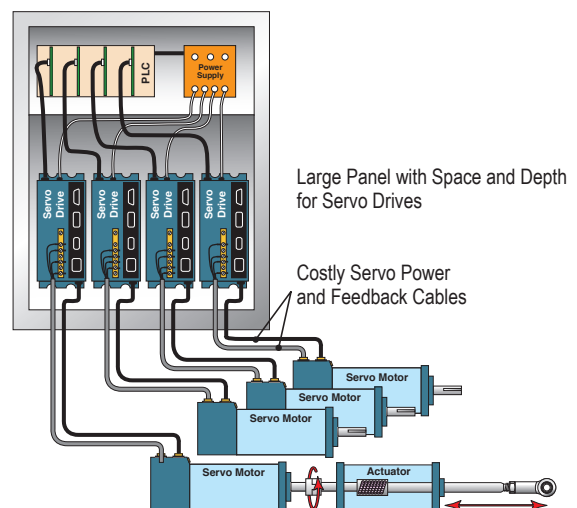

Linear Applications

Tritex II linear actuators employ a superior inverted roller screw mechanism for converting rotary motion to highly robust and long-life linear motion. These characteristics enable the Tritex II actuator to solve applications that previously required pneumatic or hydraulic cylinders. No additional mechanisms (such as acme or ball screws) are necessary to convert the actuator's rotary power into linear motion in order to move the load.

Ideal for mobile and remote applications using DC power sources, the Tritex II DC actuators have the power needed to perform. The simple to configure, yet robust interface software allows either the AC or DC Tritex II actuators to perform nearly any motion control application. The Tritex II linear actuator can be programmed to follow an analog command signal, making it ideal for controlling valves and dampers in process control applications or adjustment mechanisms on mobile equipment.

Longer Stroke Lengths

If your application requires a stroke length greater than the 18 inches available with Tritex II linear units, consider mounting a rotary Tritex II actuator to an Exlar universal actuator. This combination extends stroke length up to 40 inches. Please contact Exlar for more details.

Tritex II Models

Tritex II AC Models

- T2X high mechanical capacity actuator, 75, 90, and 115 mm
- R2M rotary motor, 75, 90, and 115 mm
- R2G rotary gearmotor, 75, 90, and 115 mm

Tritex II DC Models

- TDX high mechanical capacity actuator, 60 and 75 mm
- RDM rotary motor, 60, 75, and 90 mm
- RDG rotary gearmotor, 60, 75, and 90 mm

Feedback Types (All Models)

- Analog Hall w/1000 count resolution
- Incremental encoder with 8192 count resolution
- Absolute Feedback (analog hall with multi-turn, battery backup)

Communications & I/O

The I/O count and type varies with each actuator model and option selected. Please see page 45 for Tritex II AC and page 72 for Tritex II DC models.

Standard Communications (All Models):

- 1 RS485 port, Modbus RTU, opto-isolated for programming, controlling and monitoring

Rotary Applications

Tritex II rotary motors and gearmotors provide high response and precise control of a rotatable shaft, similar to that found in any electric motor. The difference is that with Tritex II you can program (via your PC) the rotational speed and position of the output shaft in response to external commands. For example, the motor can be commanded to rotate at a controlled velocity and to precisely stop at a preprogrammed position. You can also program the unit to run at a preset velocity until a switch input is received or a preprogrammed torque level is produced against a load. Alternatively, the rotary Tritex II actuators can be set up to follow an analog signal—either voltage or current—representing your choice of torque, velocity, or position.

Signals for initiating the preprogram-med velocity and position commands come from optically isolated inputs or directly via network communications. Likewise, isolated output commands of the status and events enable precise coordination with your system controls or machine operator.

Optional Internal Gear Reducer

If your application requires greater torque and less speed than the base unit provides, the Tritex II is available with an integral servo grade planetary gear reducer. Gear ratios of 4:1 to 100:1 allow the power of Tritex II to be applied over a broad range of torque requirements.



Tritex II rotary motor with connectors

Tritex II linear actuator with customer-supplied cable glands ports

Tritex II Series Operation

The Tritex II Series actuators can operate in one of five different motion-producing modes. These modes solve an endless variety of applications in industrial automation, medical equipment, fastening and joining, blow molding, injection molding, testing, food processing, and more.

Programmed functions are stored in the Tritex II non-volatile memory. A standard RS485 serial interface allows control, programming, and monitoring of all aspects of the motor or actuator as it performs your application. Optional communications protocols are available.

Tritex Option Boards

- Option boards offer adding functionality to the base Tritex II actuators
 - Terminal board for customer I/O
 - Isolated 4-20mA analog input and output
- Communication buses
 - EtherNet/IP
 - Modbus TCP
 - PROFINET IO

Connectivity

- Internal terminals accessible through removable cover (select models)
- Threaded ports for cable glands (select models)
- Optional connectors
 - M23 Power - M23/M16 I/O
- M8 connector for RS485
- M12 connector for EtherNet options
- Embedded leads (select models)

Operating Modes

1. *Move to a position (or switch)*
The Tritex II Series actuators allow you to execute up to 16 programmed positions or distances. You may also use a limit switch or other input device as the end condition of a move. This combination of index flexibility provides a simple solution for point-to-point indexing.
2. *Move to a preset force or torque*
The Tritex II Series allows you to terminate your move upon the achievement of a programmed torque or force. This is an ideal mode for pressing and clamping applications.
3. *Position proportional to an analog signal*
Ideal for process control solutions, the Tritex II Series provides the functionality to position a control valve by following an analog input signal. Therefore, it delivers precise valve control — which cannot be achieved by other electric, hydraulic, or pneumatic actuators.
4. *Velocity proportional to an analog signal*
Tritex II actuators offer you the capability to control velocity with an analog signal. This is particularly useful with Tritex II rotary motors which offer precise control of the speed of any process or operation.
5. *Force/torque proportional to analog signal*
Perfect for pressing and torquing applications, you can control torque with an analog input while in torque mode.

Selectable Input Functions

- Enable • Execute Move (0-15) • Dedicated Position • Jog+
- Jog- • Jog Fast • Home • Extend Switch • Retract Switch
- Home Switch • Teach Enable • Teach Move (1-16)
- Select Move • Stop • Hold • Reset Faults
- Alternate Mode (allows you to switch between 2 operating modes)

Selectable Output Functions

- Enabled • Homed • Ready (Enabled and Homed)
- Fault • Warning • Fault or Warning Active
- Move (0-15) in Progress • Homing • Jogging
- Jogging+ • Jogging- • Motion • In Position
- At Home Position • At Move (0-15) • Position
- Stopped • Holding • In Current Limit • In Current Fold Back
- Above Rated Current • Home

Expert User Interface

Expert, the Tritex II user interface software, provides you with a simple way to select all aspects of configuration and control required to set up and operate a Tritex II actuator. Easy-to-use tabbed pages provide access to input all of the parameters necessary to successfully configure your motion application. 'Application' files give you a convenient way to store and redistribute configurations amongst multiple computers, and 'Drive' files allow the same configuration to be distributed to multiple Tritex II actuators. Motion setup, homing, teach mode, tuning parameters, jogging, I/O configurations, and local control are all accomplished with ease using Expert software.

Protocol Options

The standard communication protocol for Tritex is an RS485 connection using Modbus RTU. The Modbus protocol provides a simple and robust method to connect industrial electronic devices on the same network. The Expert software acts as a Modbus Master and the Tritex II acts as the Slave device, only responding to requests commanded through the software. The Expert software allows full access to commissioning, configuring, monitoring, and controlling the Tritex II.

In addition the following protocol options are available by selecting the communication option boards. Exlar requires initial commissioning of a Tritex II actuator to be performed with the Modbus protocol.

Modbus TCP

Modbus TCP couples Modbus communication structure from Modbus RTU with EtherNet connectivity. The Modbus TCP option is fully supported by the Expert software and offers seamless

commissioning, configuring, monitoring and controlling the Tritex II. Communication protocol DSP 301 is supported as well as DSP 402 supporting Profile Torque, Profile Velocity, Profile Position and Homing. Setup on the system is most easily achieved with the Expert software using the RS485 port. A Modbus mapping table allows you to map all of the parameters you wish to read and modify into a register bank of up to 100 registers. This allows a PLC program to perform a single read operation and a single write operation to all the parameters.

EtherNet/IP

EtherNet/IP allows you to change, monitor, and control the Tritex II through implicit or explicit messaging initiated from your Rockwell PLC. Tritex parameters are set up through the Expert software using a Tritex II parameter to EtherNet/IP parameter mapping table. Up to 100 input, and 100 output 16 bit registers can be mapped to Tritex II parameters.

PROFINET IO

PROFINET IO allows you to change, monitor and control the Tritex II from your Siemens PLC. Tritex parameters are set up through the Expert software using a Tritex II parameter to PROFINET IO parameter mapping table. Up to 100 input and 100 output, 16 bit registers can be mapped to Tritex II parameters.

Modbus Mapping Screen

The screenshot displays the 'Modbus Mapping' screen within the Expert software. The interface includes a tree view on the left, a central mapping area, and a right-hand control panel. The central area shows a 'Variables List' on the left and a 'Tritex Inputs from Host Outputs' section on the right, which contains a 'Translation Table' with columns for Parameter, Consume, and Description. The 'Translation Table' lists various parameters such as '8200-Control InputEvents.Mode' and '8201-Control InputEvents.MoveLevel'. The right-hand panel features buttons for 'Enable (Momentary)', 'Enable (Maintained)', 'Stop', 'Pause', 'Jog (+)', 'Jog (-)', 'Jog Fast', 'Alternate Mode', 'Home', 'Dedicated Position', 'Define Home', 'Teach Enable', 'Reset Faults', 'Moves Maintained', 'Moves Momentary', 'Moves Teach', and 'Switches'. The bottom status bar shows 'Status: Disabled' and numerical values for Position (0.000 REVS), Velocity (0.0 RPM), and Current (0.0 AMPS), along with 'Reset Faults' and 'Diagnostics' buttons.

Motion Setup

Exlar configuration provides several templates for various applications. These can serve as your configuration, or as a starting point for your configuration. You can also begin by selecting configuration details specific to your application. At the click of a button, you can configure a move to position, move to switch, or move to force motion. Tritex II products offer absolute and incremental motion, as well as moves ending on a condition, such as a specific force or torque.

Control Page

The Expert control page gives you the ability to initiate all motion functions from one simple screen. This screen provides you with very easy system start-up and testing, without all the inconvenience of machine wiring.

The control page offers the capability to enable and disable the drive, and perform fast and slow jogs. This gives you the ability to verify motion, before needing any I/O wiring.

Monitoring and Diagnostics

All input functions can be monitored and activated from the Expert monitor page, and all output functions can be monitored. Critical fault and status data is available as a separate page, or as a fixed window on the bottom of each page of the software.

Configuring I/O

A drop down menu allows all I/O to be set up in a matter of minutes. Inputs can be configured to be maintained or momentary, depending on the application requirements. Input and output logic can be inverted with a single click.

Scope

The Expert Software includes a four-channel digital oscilloscope feature.

You can select up to four Tritex drive parameters to be monitored simultaneously.

For high speed requirements, the data can be captured in the drive's memory at an adjustable rate, down to 100 micro seconds, and then uploaded for plotting. The plots can be saved or printed, and the captured data can be saved as a comma separated file for further analysis with Excel.

Homing

You can home to an input, by using a proximity or limit switch, or home to a specific force or torque.

Homing to a force or torque is ideal for setting up applications that require motion referenced to a hard stop, like the closed position of a valve, or the final position of a press.

Teach Mode

In this mode, you can jog the actuator to the desired position, and activate an input. Alternatively, you can click a button in the Expert software and the current position of the actuator becomes the defined distance or absolute position associated with a particular move command.

EtherNet IP Mapping Screen

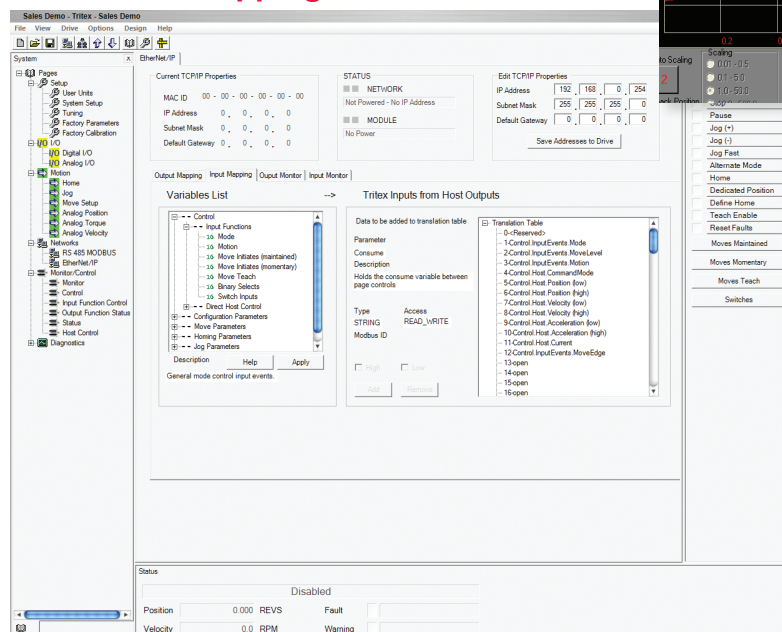

Scope

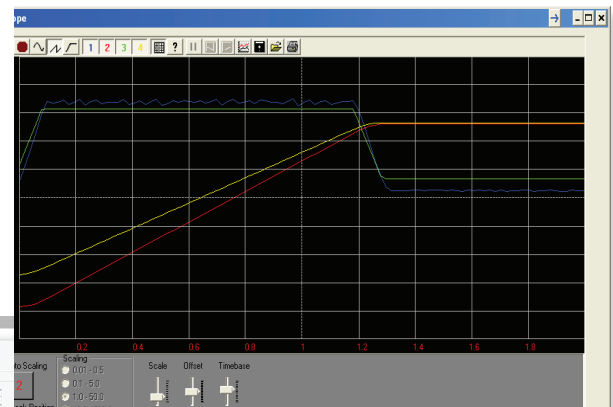

Tritex II Overview

Process Control Functionality

Precise valve and damper control are perfect applications for Tritex II actuators. They outperform other electric, hydraulic and pneumatic actuators by providing small hysteresis and dead band, quick response to small signal changes, and stable dynamic responses. Fully programmable to follow an analog or digital signal representing either position or force, the Tritex II linear actuator is well suited for control valve applications with thrust requirements up to 3225 lbf or rotary torque applications up to 95 lbf-in continuous.

The Tritex II Rotary actuators are also ideal for directly operating quarter-turn valves. Gear ratios of 4:1 to 100:1 allow the power of Tritex II to be applied to a broad range of applications, providing high turndown without loss of accuracy.

Additionally, Tritex II actuators can be mounted on any valve from any manufacturer giving you maximum flexibility.

Valve Software

The valve software is simple to use and features a teach mode for foolproof stroke configuration. A programmable valve cut off position enables a firm valve seat on either new valves or retrofitted valves. Several diagnostics and auxiliary I/O options are also available.

Class I, Division 2 Rating

Exlar Tritex II actuators are available for applications requiring CSA Class I Division 2 certification. Ordering a standard I/O interconnect with or without 4-20 mA Analog I/O, and the N option for the NPT port will provide you with a Class I Division 2 rated product.

Benefits for Process Control Applications

Extreme Accuracy

The Exlar actuators stroke the valve based on position, not air or oil pressure. Accuracy and repeatability are better than 0.1%.

100% Duty Cycle

A roller screw provides a unique way of converting rotary motor motion to a linear force, and offers full modulation capability. Life is measured in hundreds of million strokes vs. thousands like typical electric actuators.

Built in Positioner

Tritex II actuators include a built in positioner with a 4-20 mA or digital signal to tell you the exact stroke position. An analog output is also available.

Flexibility

These actuators include digital I/O and analog control. This provides the user with options for additional control such as emergency stop, +/- jog, or various diagnostic conditions.

Low Power Consumption

The Tritex II actuator only uses the current needed for a given force. This extreme efficiency makes it suitable for use with solar panels and batteries.

Fast Response and Stroke Speeds

Most other electric actuators are known for being slow—a major disadvantage. Tritex II response rate is measured in milliseconds. Stroke speeds can be up to 33 in/sec.

The screenshot displays the Tritex II valve software interface, which is organized into several functional areas:

- Actuator Direction:** A dropdown menu set to "Extend to Close".
- Close Valve / Open Valve:** Two columns of input fields for "Parameters when valve is Closed" and "Parameters when valve is Open". Values include 4.000 mA, 20.000 mA, and 0.000 REVS.
- Valve Stroke:** A text box explaining that the stroke length is the difference between the Open and Closed Valve Positions, with a note that the Open Valve Position must be greater.
- Velocity / Acceleration:** Input fields for "Velocity Limit" (100.0 RPM) and "Acceleration Limit" (3000 RPM/S).
- Manual Teach Controls:** A section with a "Digital (Jog) Mode" button and four jog buttons: "Jog to Closed Position", "Seating Current", "Jog to Open Position", and "Teach Closed Position", "Teach Open Position".
- Diagnosis / Status:**
 - Power-Up:** Shows 69 Time and 19.08 HRS.
 - Last Fault/Warning:** A table listing various faults like Peak Current, Continuous Current, Position Tracking, etc., with their counts and times.
 - Recent Fault History:** A table listing recent faults such as "Communications", "Following Error", and "Position Tracking" with their occurrence times.
 - Maximum Stress Values:** A table showing current (20.5 AMPS), voltage (114.72 VOLTS), board temp (52.5 DEGC), and actuator temp (0.0 DEGC).
 - Clear Run Time / Current Power-On Stress Values:** A table showing current (0.0) and voltage (23.91).
- Valve Seating:** A section for configuring "Close Valve" and "Open Valve" travel cut-off positions (0.00% and 100.00%) and seating limits (Seating Velocity: 10.0 RPM, Peak Seating Current: 2.0 AMPS, Foldback Seating Current: 2.0 AMPS).

Hydraulic Replacement

Tritex actuators have the same capabilities as a hydraulic equivalent, but without the cost or maintenance issues. High force, fast speeds and precise movements make it a superior substitute for hydraulic applications.

Absolute Feedback

The absolute feedback option gives the actuator memory after teaching the valve limits. So upon power loss, the battery backup will maintain the valve limits.

Diagnostics

All inputs and outputs can be monitored including position, temperature, current, and many more. An oscilloscope feature allows you to select up to four parameters to be monitored simultaneously. The data can be captured in the drive's memory at an adjustable rate, down to 100 micro sec, and then uploaded for plotting.

Tritex II Agency Approval

If your application requires CSA Class I, Division 2 Certification, please order the "N" connection option for the NPT port. This, in combination with one of the following I/O option boards, will provide Class I, Division 2 Certification:

- SIO • EIN • TCN • IA4 • PIN

Shown below are additional agency approvals applied to Tritex II Actuators.

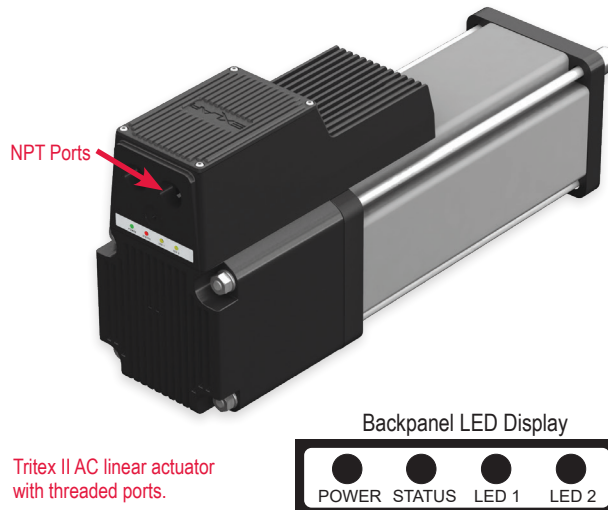

Tritex II DC Standards/Agency Approvals	
Agency/Standard	Tritex II Models/Options
CE, EMC EN61800-3	All models
CSA 139	All models, when supply voltage is 24 VDC or less
CSA Class I, Div 2, Groups A, B, C, D	75 and 90 mm frames require NPT connection option (N/A with 60 mm frame)
IP Rating	TDX = IP65S, RDM/G = IP65
Vibration Rating	IEC 60068-2-64 random vibration standard, 5g rms, 50 to 500 Hz.
ODVA	EIP
PROFINET	PIO

Tritex II AC Standards/Agency Approvals	
Agency/Standard	Tritex II Models/Options
CE, EMC EN61800-3, Safety EN 61800-5-1	All options
CSA 139	All options
CSA Class I, Div 2, Groups A, B, C, D	Requires NPT connection option. Option Board EIN, PIN, TCN, and SIO, or IA4
UL 508 C, Type 4 Enclosure T2M090/R2M090 T2M115/R2M115	Requires NPT connection option. Option Board EIN, PIN, TCN, and SIO, or IA4
IP Rating	TDX = IP65S, T2X = IP65S R2M/G & RDM/G = IP65S, R2M/G075, RDM/G075 = IP65S
Vibration Rating	IEC 61800-5-1 safety standard for drives. 1g peak, up to 150 Hz for <2 hrs. IEC 60068-2-64 random vibration standard, 2.5 g rms, 5 to 500 Hz.
ODVA	EIP

Up-to-date certifications for all products shown on www.exlar.com.

Tritex II AC

No Compromising on Power, Performance or Reliability

With forces to approximately 3,225 lbf (14 kN) continuous and 5,400 lbf peak (24 kN), and speeds to 33 in/sec (800 mm/sec), the AC Tritex II linear actuators also offer a benefit that no other integrated product offers: POWER! No longer are you limited to trivial amounts of force, or speeds so slow that many motion applications are not possible. And the Tritex II with AC power electronics operates with maximum reliability over a broad range of ambient temperatures: -40°C to +65°C. The AC powered Tritex II actuators contain a 1.5 kW servo amplifier and a very capable motion controller. With standard features such as analog following for position, compound moves, move chaining, and individual force/torque control for each move, the Tritex II Series is the ideal solution for most motion applications.

Tritex II Models

- T2X high mechanical capacity actuator-75, 90, and 115 mm
- R2M rotary motor
- R2G rotary gearmotor

Power Requirements

- AC Power 100V - 240V, +/- 10%, single phase
- Built-in AC line filter
- Connections for external braking resistor

Feedback Types

- Analog Hall with 1000 count/motor rev resolution
- Incremental encoder with 8192 count resolution
- Absolute Feedback (analog hall with multi-turn, battery backup)

Connectivity

- Internal terminals accessible through removable cover
- Threaded ports for cable glands
- Optional connectors:
 - M23 Power
 - M16 I/O (M23 on 75 mm)
- M8 connector for RS485
- M12 connector for Ethernet options
- Custom connection options

Tritex II AC Linear Actuator (90 mm)



Technical Characteristics	
Frame Sizes in (mm)	2.9 (75), 3.5 (90), 4.5 (115)
Screw Leads	0.1 (2), 0.2 (5), 0.5 (13), 0.75 (19)
Standard Stroke Lengths in (mm)	3 (76), 4 (102), 6 (152), 10 (254), 12 (305), 14 (356), 18 (457)
Force Range	up to 3225 lbf (14 kN)
Maximum Speed	up to 33.3 in/s (846 mm/s)

Operating Conditions and Usage		
Accuracy:		
Screw Lead Error	in/ft (µm / 300 mm)	0.001 (25)
Screw Travel Variation	in/ft (µm / 300 mm)	0.0012 (30)
Screw Lead Backlash	in	0.004 (T2X),
Ambient Conditions:		
Standard Ambient Temperature	°C	0 to 65
Extended Ambient Temperature**	°C	-40 to 65
Storage Temperature	°C	-40 to 85
IP Rating		T2X = IP65S R2M/R2G = IP65S R2M/G075 = IP66S
NEMA ratings	T2X090/R2M090 T2X115/R2M115	UL Type 4 UL Type 4
Vibration		2.5 g rms, 5 to 500 hz

* Ratings for R2M075 at 40°C, operation over 40°C requires de-rating. Ratings for R2M090 and R2M115 at 25°C, operation over 25°C requires de-rating.

**Consult Exlar for extended temperature operation.

Communications & I/O

Digital Inputs:

10 to 30 VDC Opto-isolated

Digital Outputs:

30 VDC maximum

100 mA continuous output Isolated

Analog Input AC:

0-10V or +/-10V

0-10V mode, 12 bit resolution

+/-10V mode, 12 bit resolution on 90/115, 13 bit resolution on

75 assignable to Position, Velocity,

Torque, or Velocity Override commands.

Analog Output AC:

0-10V

12 bit resolution on 90/115, 11 bit resolution on 75

IA4 option:

4-20 mA input

16 bit resolution Isolated

Assignable to Position, Velocity, or Torque command

4-20 mA output

12 bit resolution

Assignable to Position, Velocity, Current, Temperature, etc

Standard Communications:

- 1 RS485 port, Modbus RTU, opto-isolated for programming, controlling and monitoring

The IO count and type vary with the actuator model and option module selected.

All models include isolated digital IO, and an isolated RS485 communication port when using Modbus RTU protocol.

Tritex II AC I/O			
	75/90/115 mm frame with SIO, EIP, PIO, TCP	90/115 mm frame with IA4	75 mm frame with IA4
Isolated digital inputs	8	8	4
Isolated digital outputs	4	4	3
Analog input, non isolated	1	1	0
Analog output, non isolated	1	1	0
Isolated 4-20ma input	0	1	1
Isolated 4-20ma output	0	1	1

Product Features

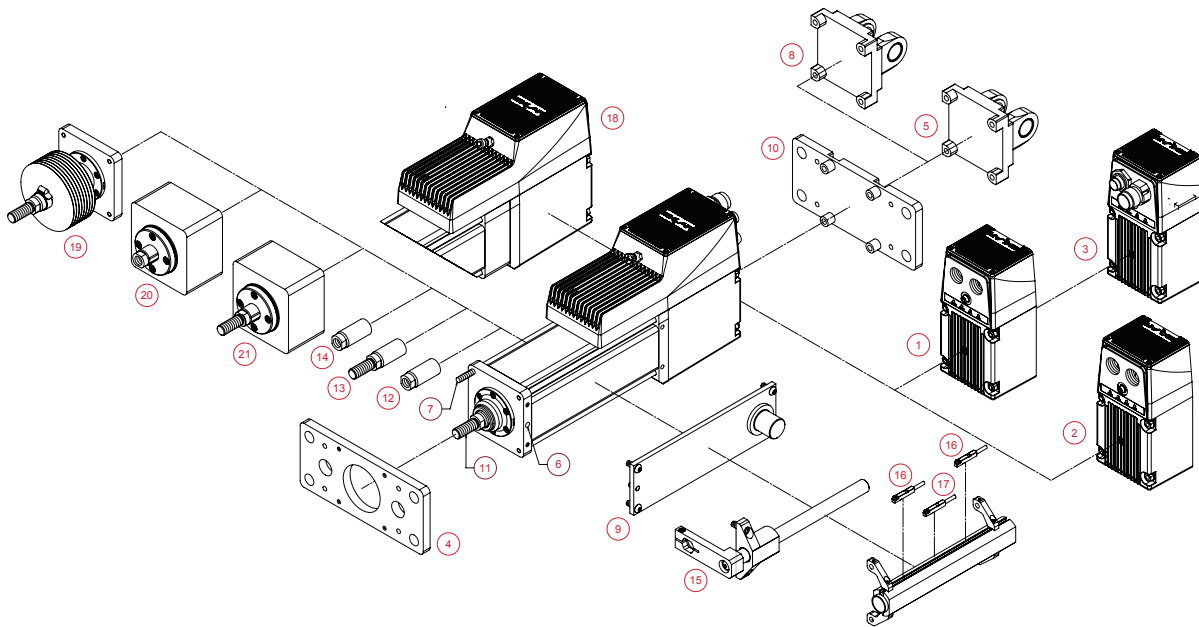
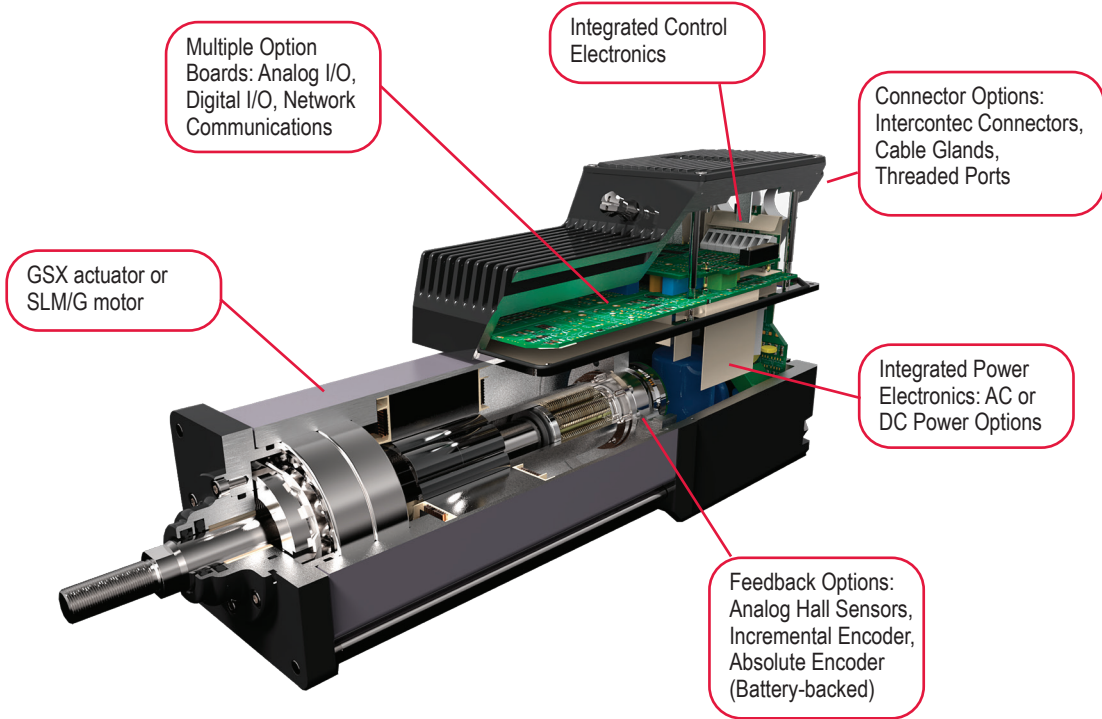

- 1 - Standard Straight Threaded Port with Internal terminals, M20 x 1.5
- 2 - NPT Threaded Port via Adapter with Internal Terminals, 1/2" NPT
- 3 - Intercontec Style - Exlar standard, M16/M23 Style Connector
- 4 - Front flange
- 5 - Rear clevis
- 6 - Double side mount and metric double side mount
- 7 - Extended tie rods and metric extended tie rods
- 8 - Metric rear clevis
- 9 - Side trunnion and metric side trunnion
- 10 - Rear flange
- 11 - Male, metric thread
- 12 - Female, metric thread
- 13 - Male, US standard thread
- 14 - Female, US standard thread
- 15 - External anti-rotate
- 16 - External limit switch - N.C., PNP
- 17 - External limit switch - N.O., PNP
- 18 - Rear brake
- 19 - Protective bellows
- 20 - Splined main rod - Female
- 21 - Splined main rod - Male

Industries and Applications

Hydraulic cylinder replacement
Ball screw replacement
Pneumatic cylinder replacement

Automotive

Clamping
Dispensing
Automated Assembly
Flexible Tooling

Food Processing

Depositing
Slicing
Diverters / Product Conveyance
Sealing

Process Control

Oil & Gas Wellhead Valve Control
Pipeline Valve Control
Damper Control
Knife Valve Control
Chemical pumps

Entertainment / Simulation

Ride Motion Bases
Animatronics

Medical Equipment

Volumetric Pumps

Plastics

Forming
Part Eject
Core Pull

Material Handling

Robotic End Effectors
Edge Guiding

Efficient food processing and packaging operations demand robust technologies that are powerful, durable, precise, and safe for food. Exlar products are ideal for these for harsh, high-capacity production environments

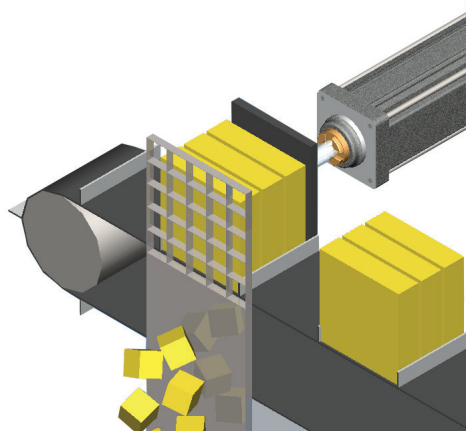

Exlar actuators can provide precision at high force loads for fluid dispensing in a medical environment.

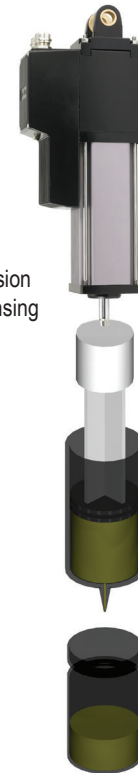

Mechanical Specifications

T2X075

		Stator	1 Stack	2 Stack	3 Stack
Lead		RPM @ 240 VAC	4000	3000	2000
0.1	Continuous Force	lbf (N)	589 (2,620)	990 (4,404)	NA
	Peak Force	lbf (N)	1,178 (5,240)	1,980 (8,808)***	NA
	Max Speed	in/sec (mm/sec)	6.67 (169)	5.00 (127)	NA
	T2X - C _a (Dynamic Load Rating)	lbf (N)	5516 (24536)		NA
0.2	Continuous Force	lbf (N)	334 (1,486)	561 (2,496)	748 (3,327)
	Peak Force	lbf (N)	668 (2,971)	1,122 (4,991)	1,495 (6,650)
	Max Speed	in/sec (mm/sec)	13.33 (339)	10.00 (254)	6.67 (169)
	T2X - C _a (Dynamic Load Rating)	lbf (N)	5800 (25798)		
0.5	Continuous Force	lbf (N)	141 (627)	238 (1,059)	317 (1,410)
	Peak Force	lbf (N)	283 (1,259)	475 (2,113)	633 (2,816)
	Max Speed	in/sec (mm/sec)	33.33 (847)	25.00 (635)	16.67 (423)
	T2X - C _a (Dynamic Load Rating)	lbf (N)	4900 (21795)		
Drive Current @ Continuous Force	Amps	3.1	3.8	3.6	
Available Stroke Lengths	in (mm)	3 (76), 6 (150), 10 (254), 12 (305), 14 (356), 18 (457)			
Inertia (zero stroke)	lb-in-s ² / Kg-m ²	0.002655 (0.000003000)	0.002829 (0.000003196)	0.003003 (0.0000033963)	
Inertia Adder (per inch of stroke)	lb-in-s ² /in/ Kg-m ² /in	0.0001424 (0.0000001609)			
Approximate Weight	lb (kg)	10.8 (4.9) for 3 inch stroke, 1 stack. Add 1.1 (0.5) per inch of stroke. Add 1.1 (0.5) per motor stack. Add .8 (0.4) for brake.			
Operating Temperature Range ¹		-20C to 65C (-40°C available, consult Exlar)			
Continuous AC Input Current ²	Amps	4.3	4	3.6	

* Ratings based on 40°C conditions. ** Continuous input current rating is defined by UL and CSA *** T2X peak force for 0.1 inch lead is 1980 lbf (8808 N)

T2X090

		Stator	1 Stack	2 Stack	2 Stack
Lead		RPM @ 240 VAC	4000	4000	3000
0.1	Continuous Force	lbf (N)	1,130 (5062)	1,488 (6619)	NA
	Peak Force	lbf (N)	2,260 (10053)	2,700 (12010)***	NA
	Max Speed	in/sec (mm/sec)	6.67 (169)	6.67 (169)	NA
	T2X - C _a (Dynamic Load Rating)	lbf (N)	5516 (24536)		NA
0.2	Continuous Force	lbf (N)	640 (2847)	843 (3750)	1,113 (4951)
	Peak Force	lbf (N)	1,281 (5698)	1,687 (7504)	2,225 (9897)
	Max Speed	in/sec (mm/sec)	13.33 (338)	13.33 (338)	10.00 (254)
	T2X - C _a (Dynamic Load Rating)	lbf (N)	5800 (25798)		
0.5	Continuous Force	lbf (N)	271 (1205)	357 (1588)	471 (2095)
	Peak Force	lbf (N)	542 (2410)	714 (3176)	942 (4190)
	Max Speed	in/sec (mm/sec)	33.33 (847)	33.33 (847)	25.00 (635)
	T2X - C _a (Dynamic Load Rating)	lbf (N)	4900 (21795)		
Drive Current @ Continuous Force	Amps	5.7	7.5	7.5	
Available Stroke Lengths	in (mm)	3 (75), 6 (150), 10 (254), 12 (300), 18 (450)			
Inertia (zero stroke)	lb-in-s ² / Kg-m ²	0.002655 (0.000003000)	0.002829 (0.000003196)	0.003003 (0.0000033963)	
Inertia Adder (per inch of stroke)	lb-in-s ² /in/ Kg-m ² /in	0.0001424 (0.0000001609)			
Approximate Weight	lb (kg)	14 (6.35) for 3 inch stroke, 1 stack. Add 1 (0.5) per inch of stroke. Add 3 (1.4) per motor stack. Add 3 (1.4) for brake.			
Operating Temperature Range ¹		-20 to 65° C (-40°C available, consult Exlar)			
Continuous AC Input Current ²	Amps	6.3	6.3	6.3	

* Ratings based on 25°C conditions. ** Continuous input current rating is defined by UL and CSA. *** T2X peak force for 0.1 inch lead is 2700 lbf (12010 N)

T2X115

		Stator	1 Stack	2 Stack	2 Stack
Lead		RPM @ 240 VAC	3000	2000	1500
0.1	Continuous Force	lbf (N)	2,060 (9,163)	3,224 (14,341)	NA
	Peak Force	lbf (N)	4,120 (18,327)	5,400 (24,020)***	NA
	Max Speed	in/sec (mm/sec)	5.00 (127)	3.33 (84)	NA
	T2X - C _a (Dynamic Load Rating)	lbf (N)	7900 (35141)		NA
0.2	Continuous Force	lbf (N)	1,177 (5,235)	1,843 (8,198)	2,380 (10,586)
	Peak Force	lbf (N)	2,354 (10,471)	3,685 (16,392)	4,760 (21,174)
	Max Speed	in/sec (mm/sec)	10.00 (254)	6.67 (169)	5.00 (127)
	T2X - C _a (Dynamic Load Rating)	lbf (N)	8300 (36920)		
0.5	Continuous Force	lbf (N)	530 (2,358)	829 (3,688)	1,071 (4,764)
	Peak Force	lbf (N)	1,059 (4,711)	1,658 (7,375)	2,142 (9,528)
	Max Speed	in/sec (mm/sec)	25.00 (635)	16.67 (423)	12.50 (317)
	T2X - C _a (Dynamic Load Rating)	lbf (N)	7030 (31271)		
0.75	Continuous Force	lbf (N)	353 (1,570)	553 (2,460)	714 (3,176)
	Peak Force	lbf (N)	706 (3,140)	1,106 (4,920)	1,428 (6,352)
	Max Speed	in/sec (mm/sec)	37.5 (953)	25 (635)	17.75 (450)
	T2X - C _a (Dynamic Load Rating)	lbf (N)	6335 (28179)		
Drive Current @ Continuous Force	Amps	8.5	8.5	8.5	
Available Stroke Lengths	in (mm)	4 (102), 6 (150), 10 (254), 12 (300), 18 (450)			
Inertia (zero stroke)	lb-in-s ² / Kg-m ²	0.01132 (0.000012790)	0.01232 (0.00001392)	0.01332 (0.00001505)	
Inertia Adder (per inch of stroke)	lb-in-s ² /in/ Kg-m ² /in	0.0005640 (0.0000006372)			
Approximate Weight	lb (kg)	34 (15.5) for 6 inch stroke, 1 stack. Add 2 (1) per inch of stroke. Add 8 (4) per motor stack. Add 4 (2) for brake.			
Operating Temperature Range ¹		-20 to 65° C (-40° C available, consult Exlar)			
Continuous AC Input Current ²	Amps	8.3	8.3	8.3	

* Ratings based on 25°C conditions.

** Continuous input current rating is defined by UL and CSA.

*** T2X peak force for 0.1 inch lead is 5400 lbf (24020 N)

Rear Brake Current Draw

T2X075	0.50 Amps @ 24 VDC
T2X090	0.67 Amps @ 24 VDC
T2X115	0.75 Amps @ 24 VDC

DEFINITIONS:

Continuous Force: The linear force produced by the actuator at continuous motor torque.

Peak Force: The linear force produced by the actuator at peak motor torque.

Max Speed: The maximum rated speed produced by the actuator at rated voltage.

C_a (Dynamic Load Rating): A design constant used in calculating the estimated travel life of the roller screw.

Estimated Service Life

T2X075 and T2X090 Estimated L₁₀ Travel Life

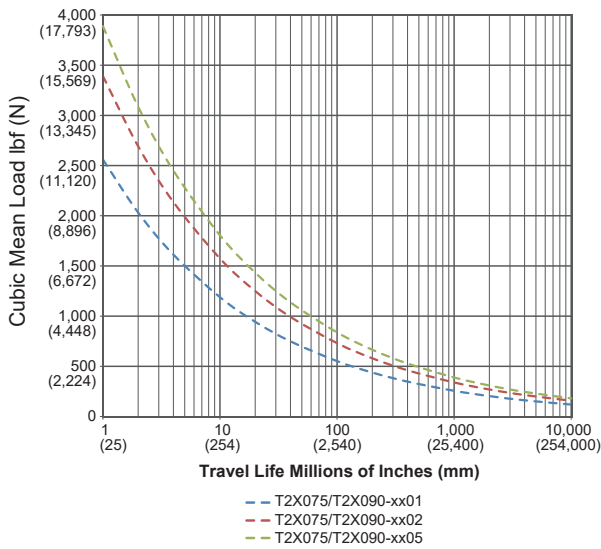

T2X115 Estimated L₁₀ Travel Life

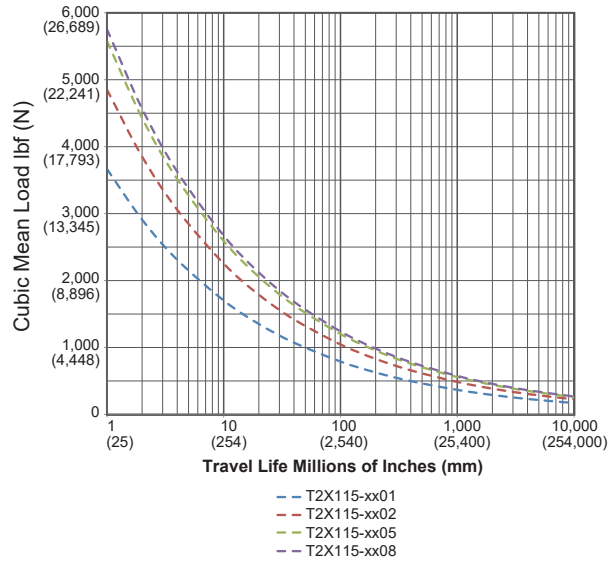

The L₁₀ expected life of a roller screw linear actuator is expressed as the linear travel distance that 90% of properly maintained roller screws are expected to meet or exceed. For higher than 90% reliability, the result should be multiplied by the following factors: 95% x 0.62; 96% x 0.53; 97% x 0.44; 98% x 0.33; 99% x 0.21. This is not a guarantee; these charts should be used for estimation purposes only.

The underlying formula that defines this value is:

Travel life in millions of inches, where:

C_a = Dynamic load rating (lbf)

F_{cmf} = Cubic mean applied load (lbf)

ℓ = Roller screw lead (inches)

$$L_{10} = \left(\frac{C_a}{F_{cmf}} \right)^3 \times \ell$$

All curves represent properly lubricated and maintained actuators.

Speed vs. Force Curves

Temperature Derating

The speed/torque curves are based on 25° C ambient conditions. The actuators may be operated at ambient temperatures up to 65° C. Use the curve (shown right) for continuous torque/force deratings above 25° C.

Note: T2X075 ratings are at 40° C.

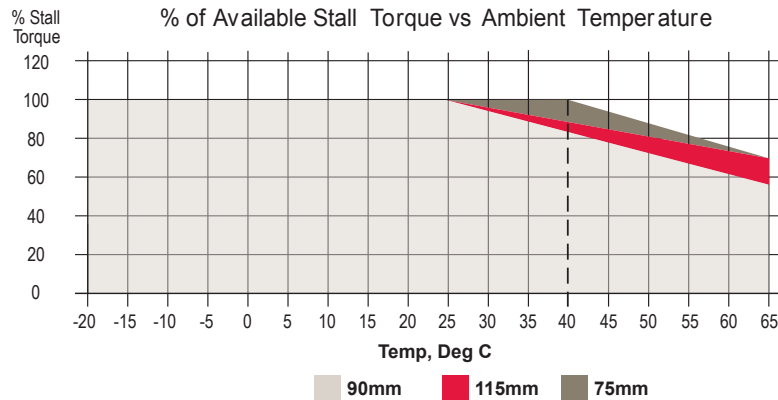

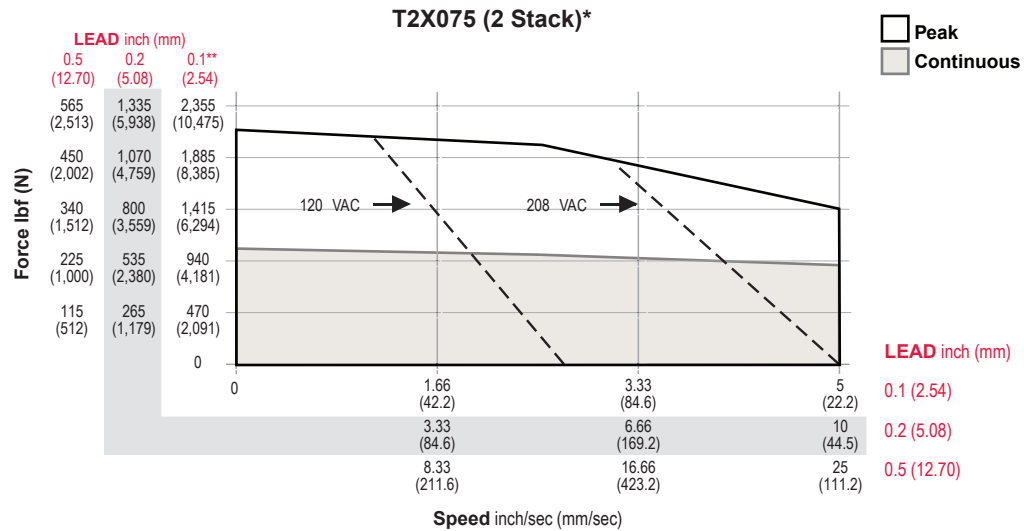
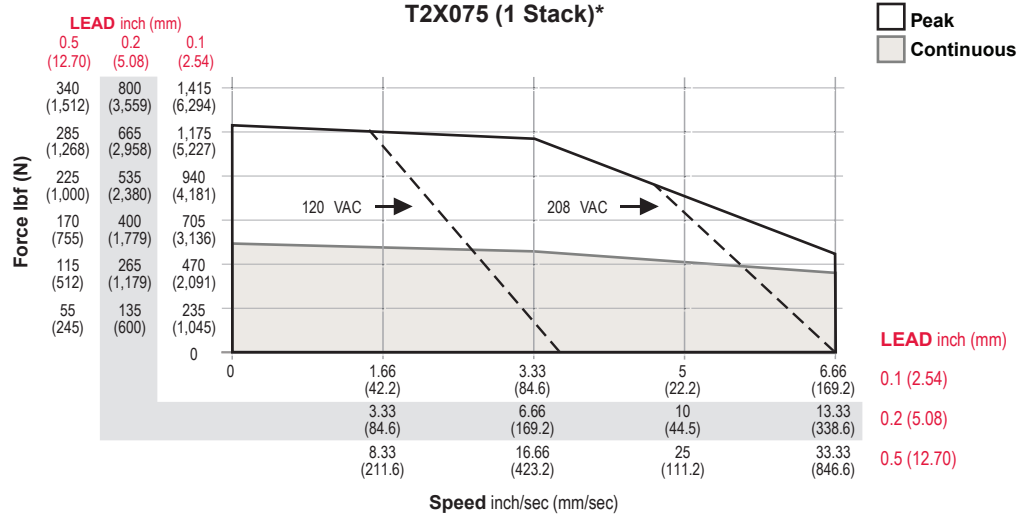

**T2X peak force for 0.1 inch lead is 1980 lbf (8808 N).

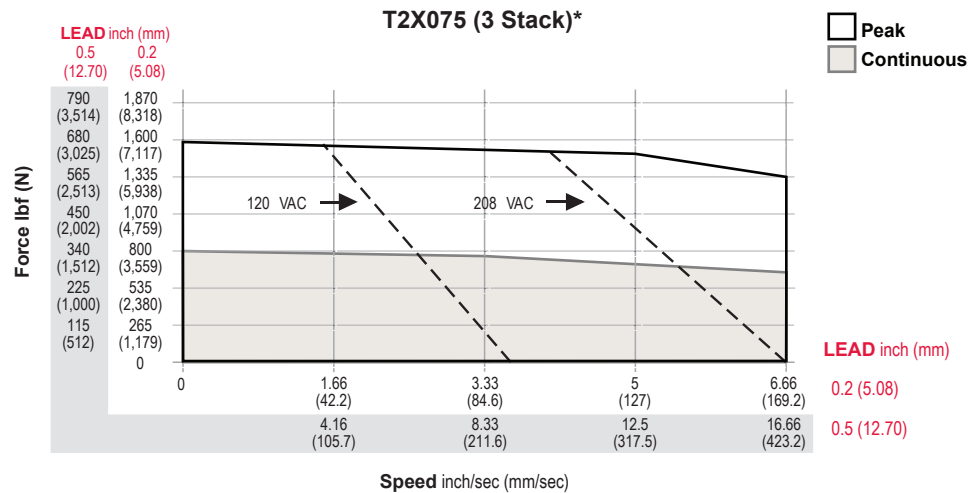

*Test data derived using NEMA recommended aluminum heatsink 10" x 10" x 3/8" at 40°C ambient.

T2X090 (1 Stack)*

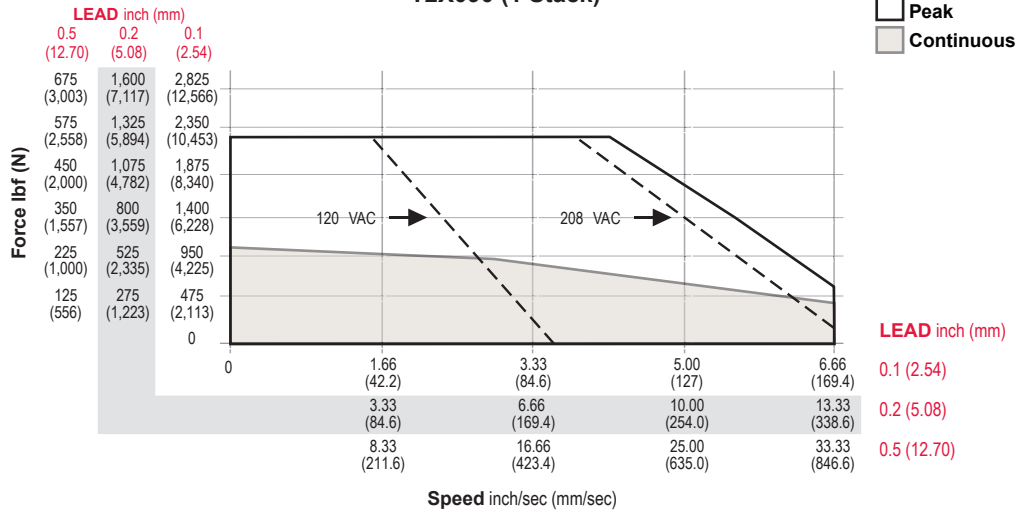

T2X090 (2 Stack, 4000 rpm)*

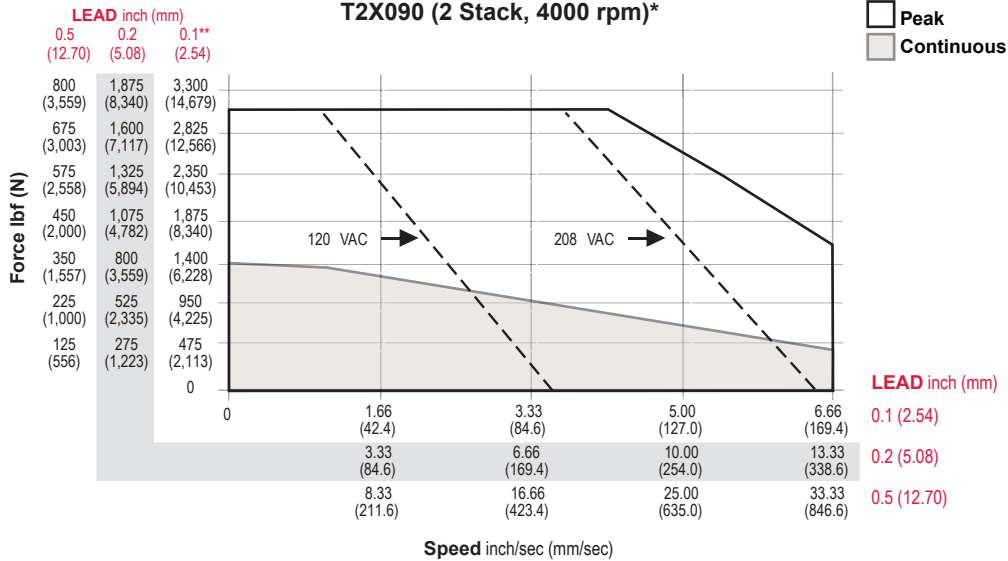

**T2X peak force for 0.1 inch lead is 2700 lbf (12010 N).

T2X090 (2 Stack, 3000 rpm)*

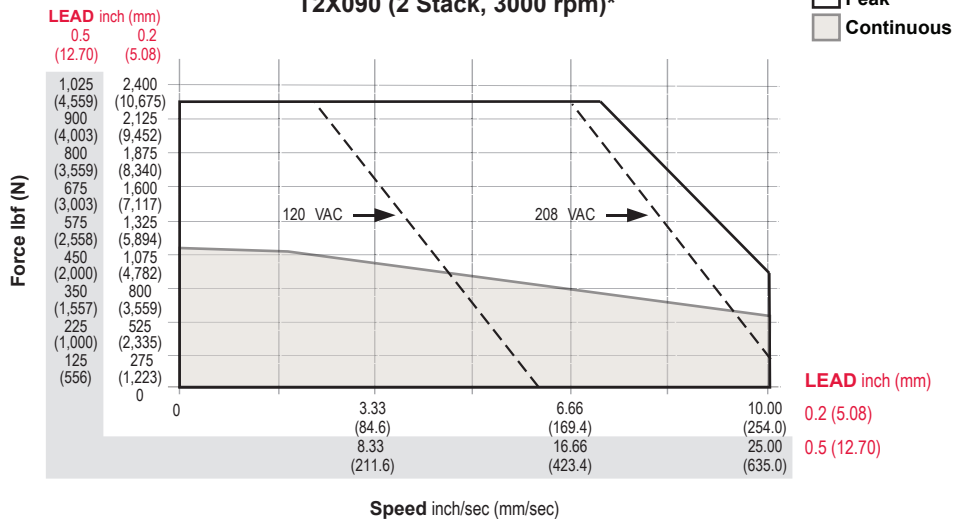

*Test data derived using NEMA recommended aluminum heatsink 10" x 10" x 3/8" at 25°C ambient.

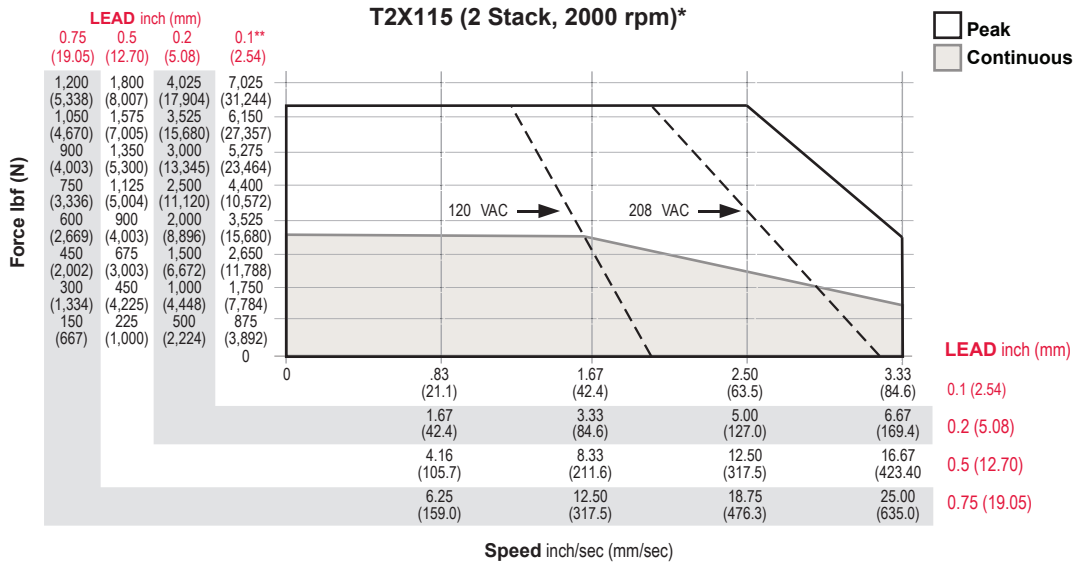
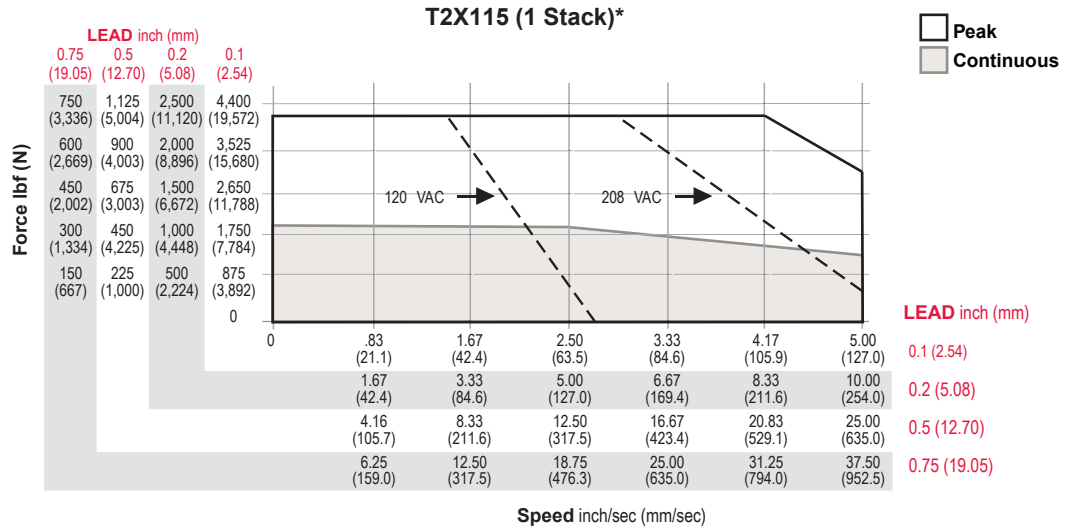

**T2X peak force for 0.1 inch lead is 5400 lbf (24020 N).

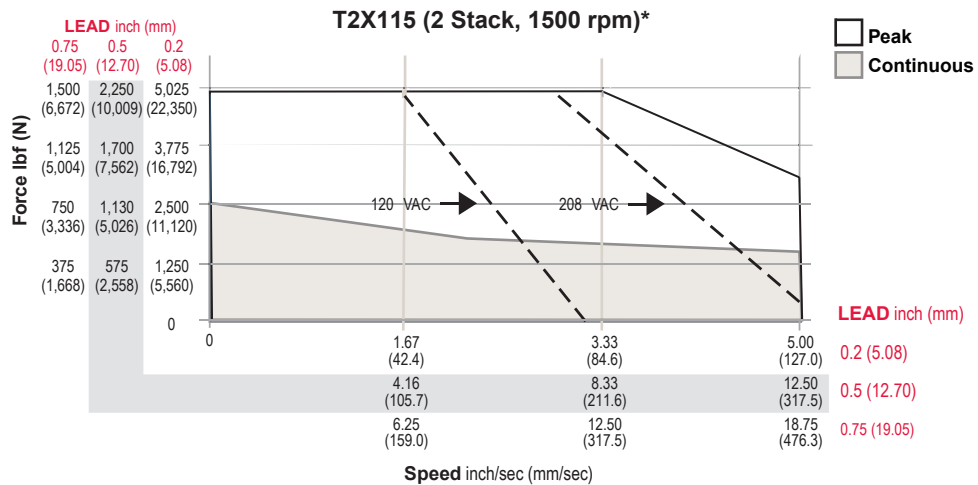

*Test data derived using NEMA recommended aluminum heatsink 12" x 12" x 1/2" at 25°C ambient.

Options

AR = External Anti-rotate Assembly

This option provides a rod and bushing to restrict the actuator rod from rotating when the load is not held by another method. Shorter actuators have single sided anti-rotation attachments. Longer lengths require attachments on both sides for proper operation. For AR dimensions, see page 56.

L1, L2, L3 = Adjustable External Travel Switches

This option allows up to 3 external switches to be included. These switches provide travel indication to the controller and are adjustable. See drawing on page 29. Must purchase external anti-rotate with this option.

PB = Protective Bellows

This option provides an accordion style protective bellows to protect the main actuator rod from damage due to abrasives or other contaminants in the environment in which the actuator must survive. The standard material of this bellows is S2 Neoprene Coated Nylon,

Sewn Construction. This standard bellows is rated for environmental temperatures of -40 to 250 degrees F. Longer strokes may require the main rod of the actuator to be extended beyond standard length. Not available with extended tie rod mounting option. Please contact your local sales representative.

RB = Rear Electric Brake

This option provides an internal holding brake. The brake is spring activated and electrically released.

SR = Splined Main Rod

A ball spline shafting main rod with a ball spline nut that replaces the standard front seal and bushing assembly. This rod restricts rotation without the need for an external mechanism. The rod diameter will be the closest metric equivalent to our standard rod sizes. Since this option is NOT sealed, it is not suitable for environments in which contaminants may enter the actuator.

Note: Adding this option affects the overall length and mounting dimensions.

Dimensions

T2X075 Double Side Mount or Extended Tie Rod Mount

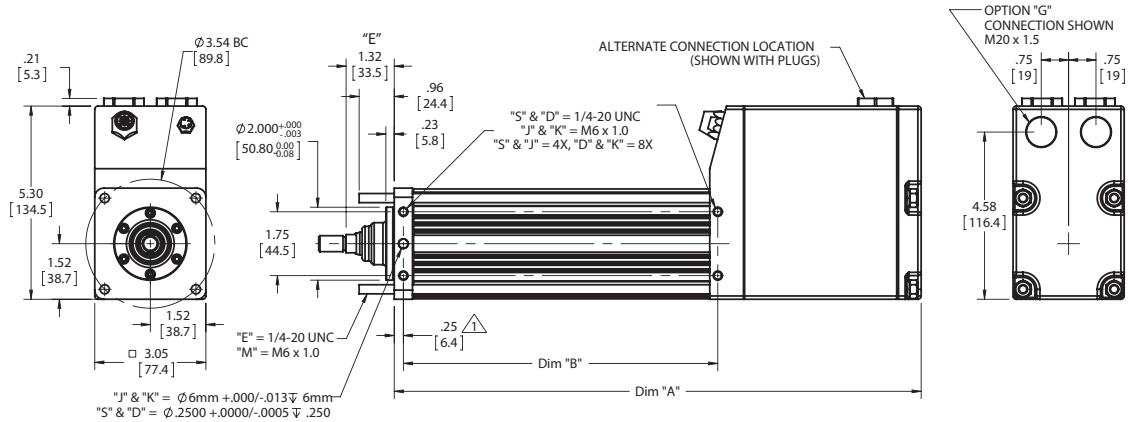

T2X075 Side Trunnion Mount or Rear Clevis Mount

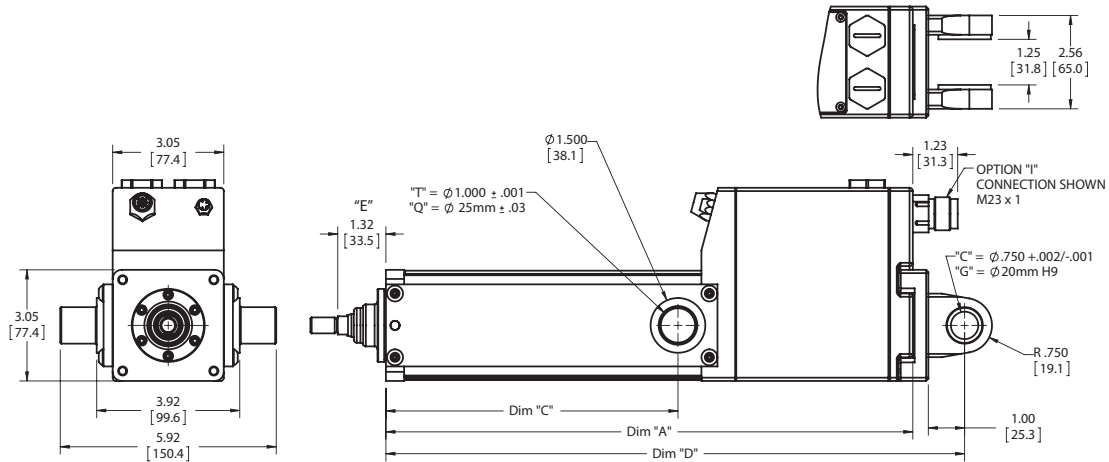

T2X075 Front, Rear, or Front and Rear Flange Mount

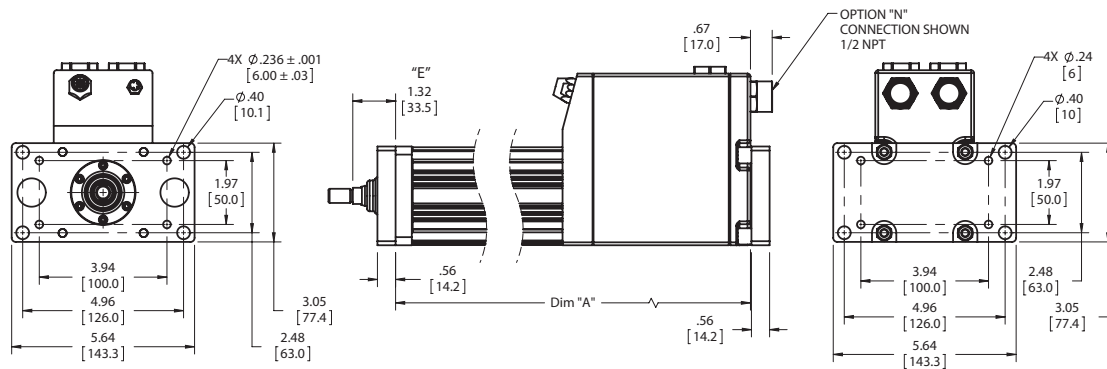

DIM	3 in (75 mm) stroke in (mm)	6 in (150 mm) stroke in (mm)	10 in (250 mm) stroke in (mm)	12 in (300 mm) stroke in (mm)	14 in (350 mm) stroke in (mm)	18 in (450 mm) stroke in (mm)
A	11.98 (304.3)	14.45 (367.0)	18.95 (481.3)	20.95 (532.1)	22.95 (582.9)	26.95 (684.5)
B	6.15 (156.2)	8.62 (218.9)	13.12 (333.2)	15.12 (384.0)	17.12 (434.8)	21.12 (536.4)
C	5.38 (136.7)	8.00 (203.2)	10.00 (254.0)	12.00 (304.8)	14.00 (355.6)	18.00 (457.2)
D	13.40 (340.4)	15.87 (403.1)	20.37 (517.4)	22.37 (568.2)	24.37 (619.0)	28.37 (720.6)

* Add 1.61 inches to dimensions "A", "B" and "D" if ordering a brake. Add 1.2 inches to dimensions "A", "C" and "D" and dimension if ordering a splined Δ main rod.

**Add 2 in (50.8 mm) to dimension "E" if ordering protective bellows.

Pre-sale drawings and models are representative and are subject to change. Certified drawings and models are available for a fee. Consult your local Exlar representative for details.

T2X090 Double Side Mount or Extended Tie Rod Mount

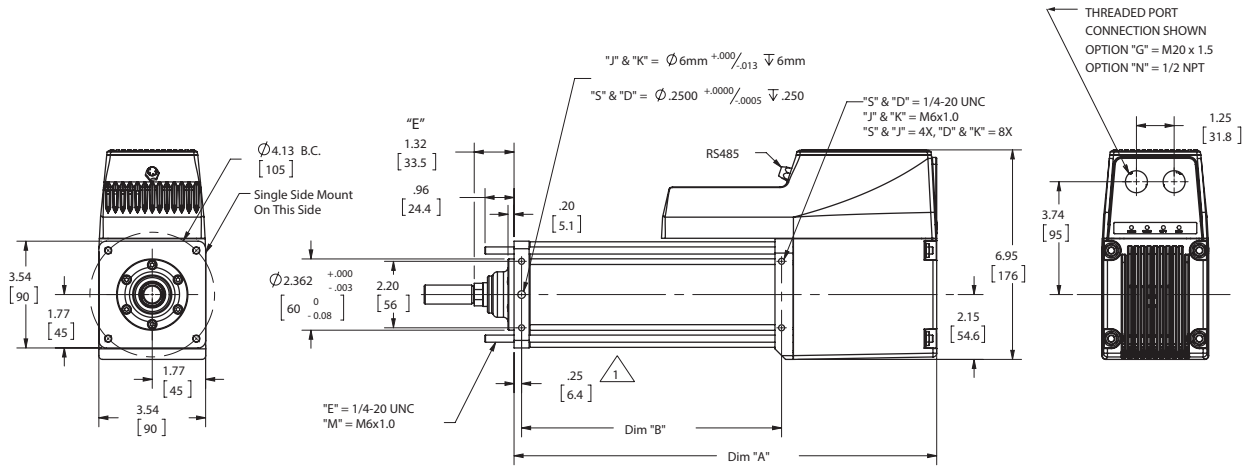

T2X090 Side Trunnion Mount or Rear Clevis Mount

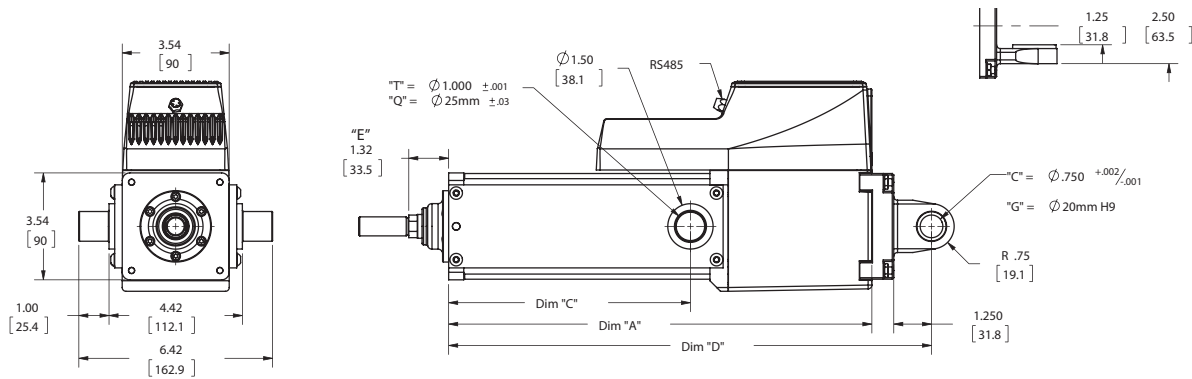

T2X090 Front, Rear, or Front and Rear Flange Mount

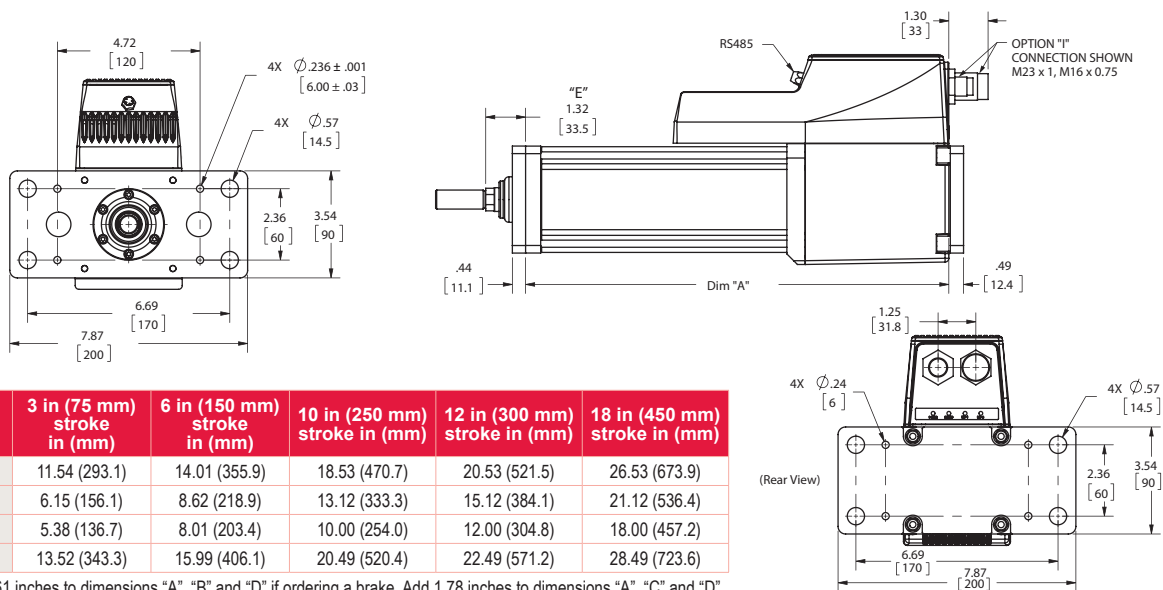

DIM	3 in (75 mm) stroke in (mm)	6 in (150 mm) stroke in (mm)	10 in (250 mm) stroke in (mm)	12 in (300 mm) stroke in (mm)	18 in (450 mm) stroke in (mm)
A	11.54 (293.1)	14.01 (355.9)	18.53 (470.7)	20.53 (521.5)	26.53 (673.9)
B	6.15 (156.1)	8.62 (218.9)	13.12 (333.3)	15.12 (384.1)	21.12 (536.4)
C	5.38 (136.7)	8.01 (203.4)	10.00 (254.0)	12.00 (304.8)	18.00 (457.2)
D	13.52 (343.3)	15.99 (406.1)	20.49 (520.4)	22.49 (571.2)	28.49 (723.6)

* Add 1.61 inches to dimensions "A", "B" and "D" if ordering a brake. Add 1.78 inches to dimensions "A", "C" and "D" and dimension if ordering a splined Δ main rod.

**Add 2 in (50.8 mm) to dimension "E" if ordering protective bellows.

Pre-sale drawings and models are representative and are subject to change. Certified drawings and models are available for a fee. Consult your local Exlar representative for details.

T2X115 Double Side Mount or Extended Tie Rod Mount

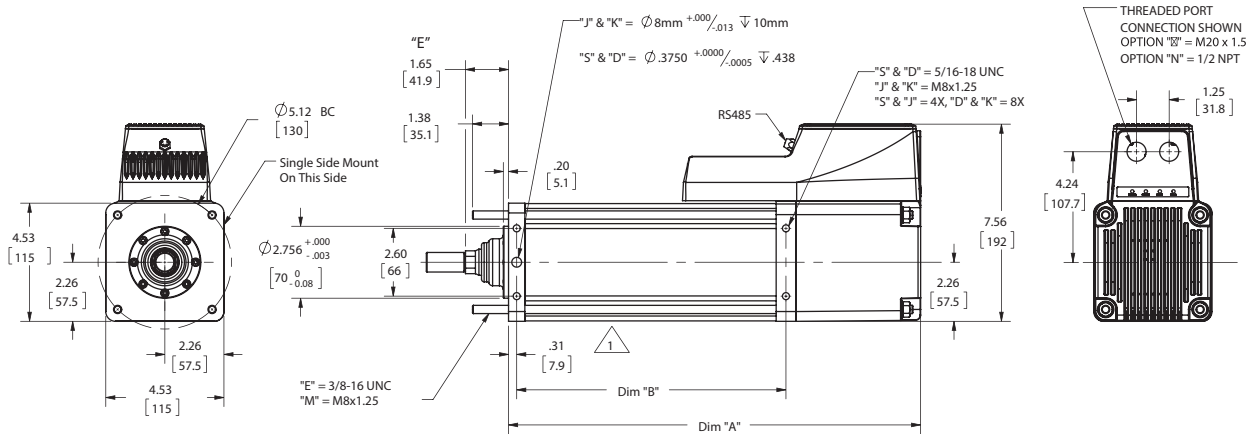

T2X115 Side Trunnion Mount or Rear Clevis Mount

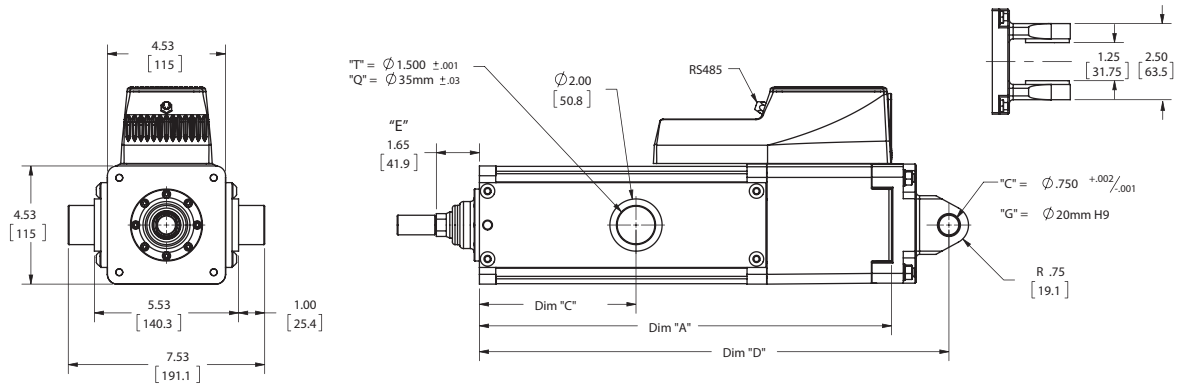

T2X115 Front, Rear, or Front and Rear Flange Mount

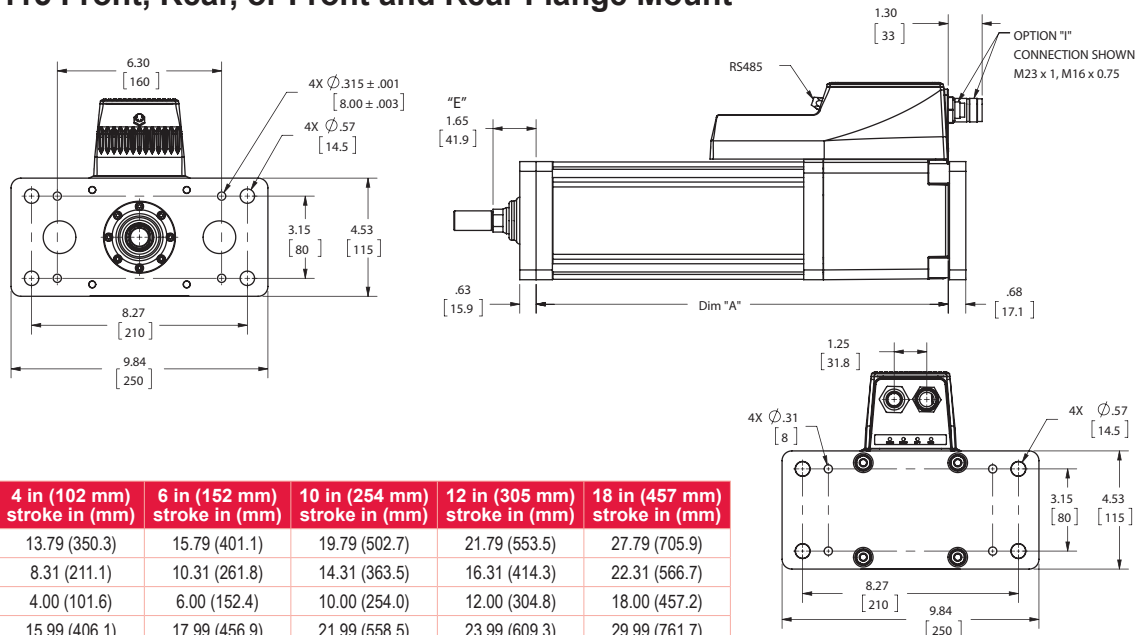

DIM	4 in (102 mm) stroke in (mm)	6 in (152 mm) stroke in (mm)	10 in (254 mm) stroke in (mm)	12 in (305 mm) stroke in (mm)	18 in (457 mm) stroke in (mm)
A	13.79 (350.3)	15.79 (401.1)	19.79 (502.7)	21.79 (553.5)	27.79 (705.9)
B	8.31 (211.1)	10.31 (261.8)	14.31 (363.5)	16.31 (414.3)	22.31 (566.7)
C	4.00 (101.6)	6.00 (152.4)	10.00 (254.0)	12.00 (304.8)	18.00 (457.2)
D	15.99 (406.1)	17.99 (456.9)	21.99 (558.5)	23.99 (609.3)	29.99 (761.7)

* Add 2.33 inches to dimensions "A", "B" and "D" if ordering a brake. Add 1.77 inches to dimensions "A", "C" and "D" and dimension if ordering a splined Δ main rod.

**Add 2 in (50.8 mm) to dimension "E" if ordering protective bellows.

Pre-sale drawings and models are representative and are subject to change. Certified drawings and models are available for a fee. Consult your local Exlar representative for details.

Anti-Rotate Option

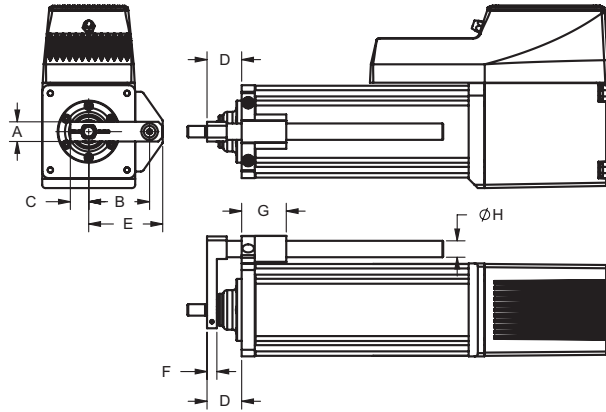

DIM in (mm)	T2X075	T2X090	T2X115
A	0.82 (20.8)	0.75 (19.1)	1.13 (28.7)
B	2.20 (56.0)	2.32 (58.9)	3.06 (77.7)
C	0.60 (15.3)	0.70 (17.8)	1.00 (25.4)
D	1.32 (33.5)	1.32 (33.5)	1.65 (41.9)
E	2.70 (68.7)	2.82 (71.6)	3.63 (92.2)
F	0.39 (9.9)	0.38 (9.7)	0.50 (12.7)
G	1.70 (43.2)	1.70 (43.2)	1.97 (50.0)
ØH	0.63 (16.0)	0.63 (16.0)	0.75 (19.1)

Actuator Rod End Option

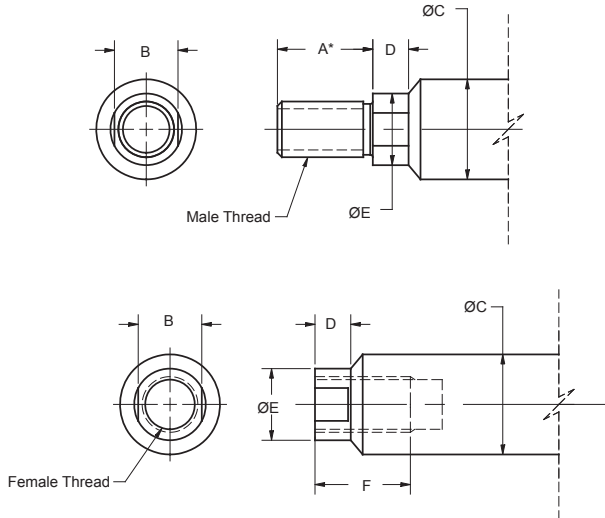

DIM in (mm)	T2X075	T2X090	T2X115
A*	0.750 (19.1)*	1.250 (31.8)	1.500 (38.1)
B	0.500 (12.7)	0.625 (17.0)	0.750 (19.1)
ØC	0.625 (15.9)	0.787 (20.0)	1.000 (25.4)
D	0.281 (7.1)	0.281 (7.1)	0.381 (9.7)
ØE	0.562 (14.3)	0.725 (18.4)	0.875 (22.2)
F	0.750 (19.1)	1.000 (25.4)	1.000 (25.4)
Male-Inch "M"	7/16-20 UNF-2A	1/2-20 UNF-2A	3/4-16 UNF-2A
Male-Metric "A"	M12 x 1.75 6g	M16 x 1.5 6g	M16 x 1.5 6g
Female-Inch "F"	7/16-20 UNF-2B	1/2-20 UNF-2B	5/8-18 UNF-2B
Female-Metric "B"	M10 x 1.5 6H	M16 x 1.5 6H	M16 x 1.5 6H

*When ordering the male M12x1.75 main rod for the T2M/X075 dimension "A" will be 1.57 in (40 mm)

Clevis Pin

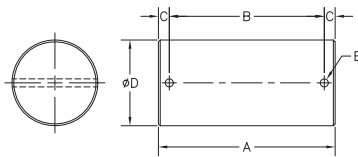

	T2X075/T2X090	T2X075/T2X090	T2X115
	CP050 Fits Rod Eye, Rod Clevis in (mm)	CP075 Fits Rear Clevis in (mm)	CP075 Fits Rod Eye, Rod Clevis, Spherical Eye, Rear Clevis in (mm)
A	2.28 (57.9)	3.09 (78.5)	3.09 (78.5)
B	1.94 (49.28)	2.72 (69.1)	2.72 (69.1)
C	0.17 (4.32)	0.19 (4.82)	1.19 (4.82)
ØD	0.50 -0.001/-0.002 (112.7 mm +0.00/-0.05)	0.75 -0.001/-0.002 (19.1 mm +0.00/-0.05)	0.75 -0.001/-0.002 (19.1 mm +0.00/-0.05)
ØE	0.106 (2.69)	0.14 (3.56)	0.14 (3.56)

Pre-sale drawings and models are representative and are subject to change. Certified drawings and models are available for a fee. Consult your local Exlar representative for details.

Spherical Rod Eye

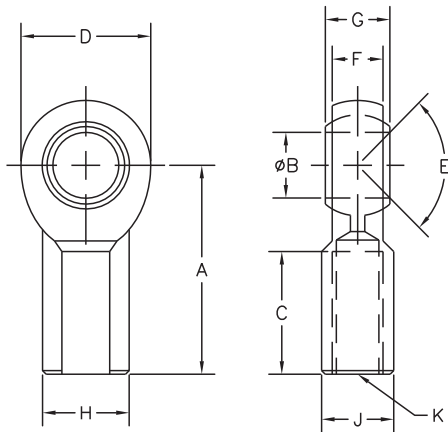

DIM in (mm)	T2X075	T2X090	T2X115
	SRM044	SRM050	SRM075
A	1.81 (46.0)	2.125 (54.0)	2.88 (73.2)
ϕB	0.438 (11.13)	0.500 (12.7)	0.75 (19.1)
C	1.06 (26.9)	1.156 (29.4)	1.72 (43.7)
D	1.13 (28.7)	1.312 (33.3)	1.75 (44.5)
E	14 Deg	6 Deg	14 Deg
F	0.44 (11.1)	0.500 (12.7)	0.69 (17.5)
G	0.56 (14.2)	0.625 (15.9)	0.88 (22.3)
H	0.75 (19.1)	0.875 (22.2)	1.13 (28.7)
J	0.63 (16.0)	0.750 (19.1)	1.00 (25.4)
K	7/16-20	1/2-20	3/4-16

Rod Eye

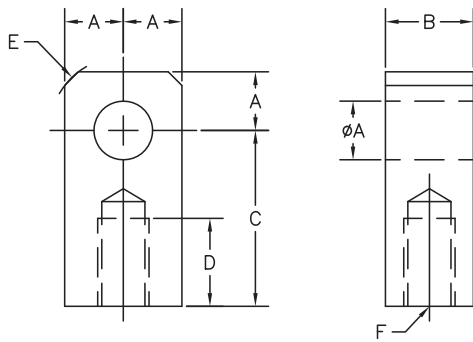

DIM in (mm)	T2X075	T2X090	T2X115
	RE050	REI050	RE075
ϕA	0.50 (12.7)	0.50 (12.7)	0.75 (19.05)
B	0.75 (19.1)	0.75 (19.05)	1.25 (31.8)
C	1.50 (38.1)	1.50 (38.1)	2.06 (52.3)
D	0.75 (19.1)	0.75 (19.05)	1.13 (28.7)
E	0.63 (15.9)	0.375 (9.53)	0.88 (22.2)
F	7/16-20	1/2-20	3/4-16

Rod Clevis

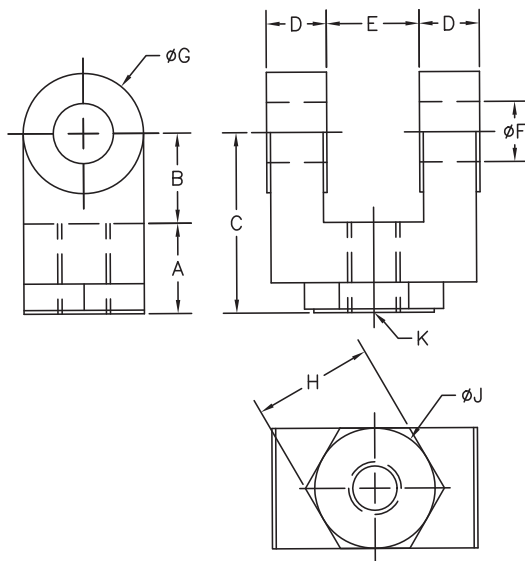

DIM in (mm)	T2X075	T2X090	T2X115
	RC050	RCI050	RC075
A	0.750 (19.05)	0.750 (19.05)	1.125 (28.58)
B	0.750 (19.05)	0.750 (19.05)	1.25 (31.75)
C	1.500 (38.1)	1.500 (38.1)	2.375 (60.3)
D	0.500 (12.7)	0.500 (12.7)	0.625 (15.88)
E	0.765 (19.43)	0.765 (19.43)	1.265 (32.12)
ϕF	0.500 (12.7)	0.500 (12.7)	0.75 (19.1)
ϕG	1.000 (25.4)	1.000 (25.4)	1.50 (38.1)
H	1.000 (25.4)	1.000 (25.4)	1.25 (31.75)
ϕJ	1.000 (25.4)	N/A	1.25 (31.75)
K	7/16-20	1/2-20	3/4-16

Pre-sale drawings and models are representative and are subject to change. Certified drawings and models are available for a fee. Consult your local Exlar representative for details.

Mechanical Specifications

R2M/G075

Rotary Motor Torque and Speed Ratings				
	Stator	1 Stack	2 Stack	3 Stack
	RPM at 240 VAC	4000	3000	2000
Continuous Torque	lbf-in (Nm)	13 (1.47)	21 (2.37)	28 (3.16)
Peak Torque	lbf-in (Nm)	25 (2.8)	42 (4.75)	56 (6.33)
Drive Current @ Continuous Torque	Amps	3.1	3.8	3.8
Operating Temperature Range*	-20 to 65° C (-40°C available, consult Exlar)			
Continuous AC Input Current**	Amps	4.3	4	3.6

*Ratings based on 40° C ambient conditions.

**Continuous input current rating is defined by UL and CSA.

For output torque of R2G gearmotors, multiply by ratio and efficiency. Please note maximum allowable output torques shown below.

Inertia				
	Stator	1 Stack	2 Stack	3 Stack
R2M Motor Armature Inertia (+/-5%)	lb-in-sec ² (kg-cm ²)	0.000545 (0.6158)	0.000973 (1.0996)	0.001401 (1.5834)
R2G Gearmotor Armature Inertia* (+/-5%)	lb-in-sec ² (kg-cm ²)	0.000660 (0.7450)	0.001068 (1.2057)	0.001494 (1.6868)

*Add armature inertia to gearing inertia for total R2G system inertia.

L ₁₀ Radial Load and Bearing Life						
RPM	50	100	250	500	1000	3000
R2M075 lbf (N)	278 (1237)	220 (979)	162 (721)	129 (574)	102 (454)	71 (316)
R2G075 lbf (N)	343 (1526)	272 (1210)	200 (890)	159 (707)	126 (560)	88 (391)

Side load ratings shown above are for 10,000 hour bearing life at 25 mm from motor face at given rpm.

Gearmotor Mechanical Ratings					
Model	Ratio	Maximum Allowable Output Torque-Set by User lbf-in (Nm)	Output Torque at Motor Speed for 10,000 Hour Life		
			1000 RPM lbf-in (Nm)	2500 RPM lbf-in (Nm)	4000 RPM lbf-in (Nm)
R2G075-004	4:1	1618 (182.8)	384 (43.4)	292 (32.9)	254 (28.7)
R2G075-005	5:1	1446 (163.4)	395 (44.6)	300 (33.9)	260 (29.4)
R2G075-010	10:1	700 (79.1)	449 (50.7)	341 (38.5)	296 (33.9)

Two torque ratings for the R2G gearmotors are given in the table above. The left hand columns give the maximum (peak) allowable output torque for the indicated ratios of each size R2G gearmotor. This is not the rated output torque of the motor multiplied by the ratio of the reducer.

It is possible to select a configuration of the motor selection and gear ratio such that the rated motor torque, multiplied by the gear ratio exceeds these ratings. It is the responsibility of the user to ensure that the settings of the system do not allow these values to be exceeded.

The right hand columns give the output torque at the indicated speed which will result in 10,000 hour life (L10). The setup of the system will determine the actual output torque and speed.

Gearing Reflected Inertia		
Single Reduction		
Gear Stages	lbf-in-sec ²	(kg-cm ²)
4:1	0.000095	(0.107)
5:1	0.000062	(0.069)
10:1	0.000017	(0.019)

Backlash and Efficiency		
	Single Reduction	Double Reduction
Backlash at 1% Rated Torque	10 Arc min	13 Arc min
Efficiency	91%	86%

Motor and Gearmotor Weights			
	R2M075 without Gears	R2G075 with 1 Stage Gearing	Added Weight for Brake
1 Stack Stator lb (kg)	7.4 (3.4)	9.8 (4.4)	1.0 (0.5)
2 Stack Stator lb (kg)	9.2 (4.2)	11.6 (5.3)	
3 Stack Stator lb (kg)	11 (4.9)	13.4 (6.1)	

R2M/G090

Rotary Motor Torque and Speed Ratings				
	Stator	2 Stack	2 Stack	3 Stack
	RPM at 240 VAC	4000	3000	2000
Continuous Torque	lbf-in (Nm)	30 (3.4)	40 (4.5)	52 (5.9)
Peak Torque	lbf-in (Nm)	60 (6.8)	80 (9.0)	105 (11.9)
Drive Current @ Continuous Torque	Amps	7.5	7.5	6.6
Operating Temperature Range*	-20 to 65° C (-40° C available, consult Exlar)			
Continuous AC Input Current**	Amps	6.3	6.3	6.3

*Ratings based on 25° C ambient conditions.

**Continuous input current rating is defined by UL and CSA.

For output torque of R2G gearmotors, multiply by ratio and efficiency. Please note maximum allowable output torques shown below.

Inertia			
	Stator	2 Stack	3 Stack
R2M Motor Armature Inertia (+/-5%)	lb-in-sec ² (kg-cm ²)	0.00097 (1.09)	0.00140 (1.58)
R2G Gearmotor Armature Inertia* (+/-5%)	lb-in-sec ² (kg-cm ²)	0.00157 (1.77)	0.00200 (2.26)

*Add armature inertia to gearing inertia for total inertia.

L ₁₀ Radial Load and Bearing Life							
RPM	50	100	250	500	1000	3000	
R2M090 lbf (N)	427 (1899)	340 (1512)	250 (1112)	198 (881)	158 (703)	109 (485)	
R2G090 lbf (N)	350 (1557)	278 (1237)	205 (912)	163 (725)	129 (574)	89 (396)	

Side load ratings shown above are for 10,000 hour bearing life at 25 mm from motor face at given rpm.

Gearmotor Mechanical Ratings					
Model	Ratio	Maximum Allowable Output Torque-Set by User lbf-in (Nm)	Output Torque at Motor Speed for 10,000 Hour Life		
			1000 RPM lbf-in (Nm)	2500 RPM lbf-in (Nm)	4000 RPM lbf-in (Nm)
R2G090-004	4:1	2078 (234.8)	698 (78.9)	530 (59.9)	460 (51.9)
R2G090-005	5:1	1798 (203.1)	896 (101.2)	680 (76.8)	591 (66.8)
R2G090-010	10:1	1126 (127.2)	1043 (117.8)	792 (89.4)	688 (77.7)
R2G090-016	16:1	2078 (234.8)	1057 (119.4)	803 (90.7)	698 (78.9)
R2G090-020	20:1	2078 (234.8)	1131 (127.8)	859 (97.1)	746 (84.3)
R2G090-025	25:1	1798 (203.1)	1452 (164.1)	1103 (124.6)	958 (108.2)
R2G090-040	40:1	2078 (234.8)	1392 (157.3)	1057 (119.4)	918 (103.7)
R2G090-050	50:1	1798 (203.1)	1787 (201.9)	1358 (153.4)	1179 (133.2)
R2G090-100	100:1	1126 (127.2)	1100 (124.3)	1100 (124.3)	1100 (124.3)

Two torque ratings for the R2G gearmotors are given in the table above. The left hand columns give the maximum (peak) allowable output torque for the indicated ratios of each size R2G gearmotor. This is not the rated output torque of the motor multiplied by the ratio of the reducer.

It is possible to select a configuration of the motor selection and gear ratio such that the rated motor torque, multiplied by the gear ratio exceeds these ratings. It is the responsibility of the user to ensure that the settings of the system do not allow these values to be exceeded.

The right hand columns give the output torque at the indicated speed which will result in 10,000 hour life (L10). The setup of the system will determine the actual output torque and speed.

Gearing Reflected Inertia					
Gear Stages	Single Reduction		Double Reduction		
	lbf-in-sec ²	(kg-cm ²)	Gear Stages	lbf-in-sec ²	(kg-cm ²)
4:1	0.000154	(0.174)	16:1	0.000115	(0.130)
5:1	0.000100	(0.113)	20:1, 25:1	0.0000756	(0.0854)
10:1	0.0000265	(0.0300)	40:1, 50:1, 100:1	0.0000203	(0.0230)

Backlash and Efficiency		
	Single Reduction	Double Reduction
Backlash at 1% Rated Torque	10 Arc min	13 Arc min
Efficiency	91%	86%

Motor and Gearmotor Weights				
	R2M090 without Gears	R2G090 with 1 Stage Gearing	R2G090 with 2 Stage Gearing	Added Weight for Brake
2 Stack Stator lb (kg)	14 (6.4)	22 (10)	25 (11.3)	1.5 (0.7)
3 Stack Stator lb (kg)	17 (7.7)	25 (11.3)	28 (12.7)	

R2M/G115

Rotary Motor Torque and Speed Ratings				
	Stator	1 Stack	2 Stack	2 Stack
	RPM at 240 VAC	3000	2000	1500
Continuous Torque	lbf-in (Nm)	47 (5.3)	73 (8.3)	95 (10.7)
Peak Torque	lbf-in (Nm)	94 (10.6)	146 (16.5)	190 (21.5)
Drive Current @ Continuous Torque	Amps	8.5	8.5	8.5
Operating Temperature Range [†]	-20 to 65° C (-40°C available, consult Exlar)			
Continuous AC Input Current ^{**}	Amps	8.3	8.3	8.3

[†]Ratings based on 25° C ambient conditions.

^{**}Continuous input current rating is defined by UL and CSA.

For output torque of R2G gearmotors, multiply by ratio and efficiency. Please note maximum allowable output torques shown below.

Inertia			
	Stator	1 Stack	2 Stack
R2M Motor Armature Inertia (+/-5%)	lb-in-sec ² (kg-cm ²)	0.00344 (3.89)	0.00623 (7.036)
R2G Gearmotor Armature Inertia*	lb-in-sec ² (kg-cm ²)	0.00538 (6.08)	0.00816 (9.22)

*Add armature inertia to gearing inertia for total R2M system inertia.

L ₁₀ Radial Load and Bearing Life						
RPM	50	100	250	500	1000	3000
R2M115 lbf (N)	579 (2576)	460 (2046)	339 (1508)	269 (1197)	214 (952)	148 (658)
R2G115 lbf (N)	858 (3817)	681 (3029)	502 (2233)	398 (1770)	316 (1406)	218 (970)

Side load ratings shown above are for 10,000 hour bearing life at 25 mm from motor face at given rpm.

Gearmotor Mechanical Ratings					
Model	Ratio	Maximum Allowable Output Torque-Set by User lbf-in (Nm)	Output Torque at Motor Speed for 10,000 Hour Life		
			1000 RPM lbf-in (Nm)	2000 RPM lbf-in (Nm)	3000 RPM lbf-in (Nm)
R2G115-004	4:1	4696 (530.4)	1392 (157.3)	1132 (127.9)	1000 (112.9)
R2G115-005	5:1	4066 (459.4)	1455 (163.3)	1175 (132.8)	1040 (117.5)
R2G115-010	10:1	2545 (287.5)	1660 (187.6)	1350 (152.6)	1200 (135.6)
R2G115-016	16:1	4696 (530.4)	2112 (238.6)	1714 (193.0)	1518 (171.0)
R2G115-020	20:1	4696 (530.4)	2240 (253.1)	1840 (207.9)	1620 (183.0)
R2G115-025	25:1	4066 (459.4)	2350 (265.5)	1900 (214.7)	1675 (189.2)
R2G115-040	40:1	4696 (530.4)	2800 (316.4)	2240 (253.1)	2000 (225.9)
R2G115-050	50:1	4066 (459.4)	2900 (327.7)	2350 (265.5)	2100 (237.3)
R2G115-100	100:1	2545 (287.5)	2500 (282.5)	2500 (282.5)	2400 (271.2)

Two torque ratings for the R2G gearmotors are given in the table above. The left hand columns give the maximum (peak) allowable output torque for the indicated ratios of each size R2G gearmotor. This is not the rated output torque of the motor multiplied by the ratio of the reducer.

It is possible to select a configuration of the motor selection and gear ratio such that the rated motor torque, multiplied by the gear ratio exceeds these ratings. It is the responsibility of the user to ensure that the settings of the system do not allow these values to be exceeded.

The right hand columns give the output torque at the indicated speed which will result in 10,000 hour life (L10). The setup of the system will determine the actual output torque and speed.

Gearing Reflected Inertia					
Single Reduction			Double Reduction		
Gear Stages	lbf-in-sec ²	(kg-cm ²)	Gear Stages	lbf-in-sec ²	(kg-cm ²)
4:1	0.000635	(0.717)	16:1	0.000513	(0.580)
5:1	0.000428	(0.484)	20:1, 25:1	0.000350	(0.396)
10:1	0.000111	(0.125)	40:1, 50:1, 100:1	0.0000911	(0.103)

Backlash and Efficiency		
	Single Reduction	Double Reduction
Backlash at 1% Rated Torque	10 Arc min	13 Arc min
Efficiency	91%	86%

Motor and RTG115 Gearmotor Weights				
	R2M115 without Gears	R2G115 with 1 Stage Gearing	R2G115 with 2 Stage Gearing	Added Weight for Brake
1 Stack Stator lb (kg)	19 (8.6)	34 (15.4)	40 (18.1)	2.7 (1.2)
2 Stack Stator lb (kg)	27 (12.2)	42 (19.1)	48 (21.8)	
3 Stack Stator lb (kg)	35 (15.9)	50 (22.7)	56 (25.4)	

Speed vs. Torque Curves

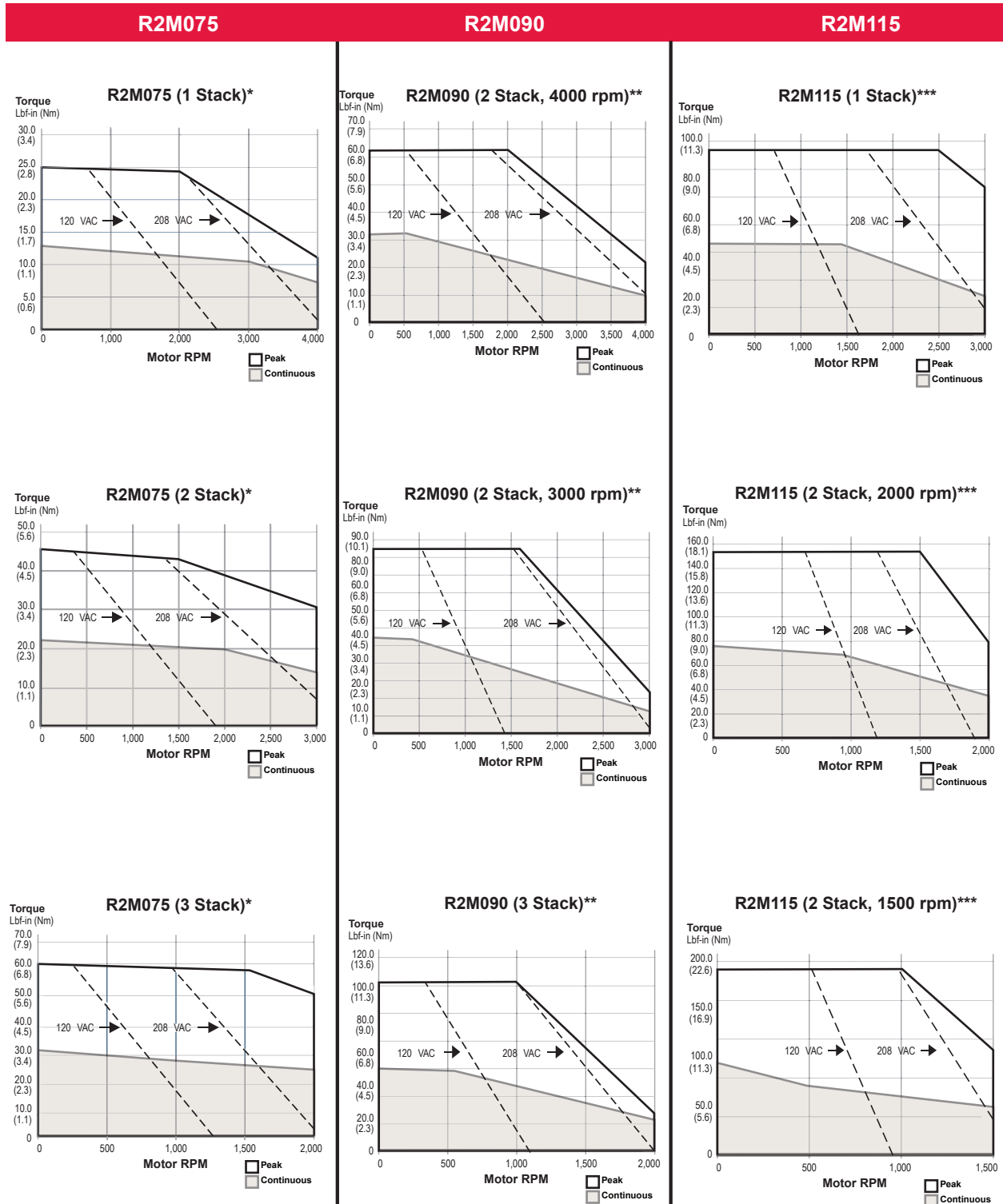

For R2G gearmotors, multiply torque by gear ratio and efficiency. Divide speed by gear ratio efficiencies; 1 Stage = 0.91, 2 Stage = 0.86

*R2M075 test data derived using NEMA recommended aluminum heatsink 10" x 10" x 3/8" at 40°C ambient.

**R2M090 test data derived using NEMA recommended aluminum heatsink 10" x 10" x 3/8" at 25°C ambient.

***R2M115 test data derived using NEMA recommended aluminum heatsink 12" x 12" x 1/2" at 25°C ambient.

Dimensions

R2M/G075 Base Actuator

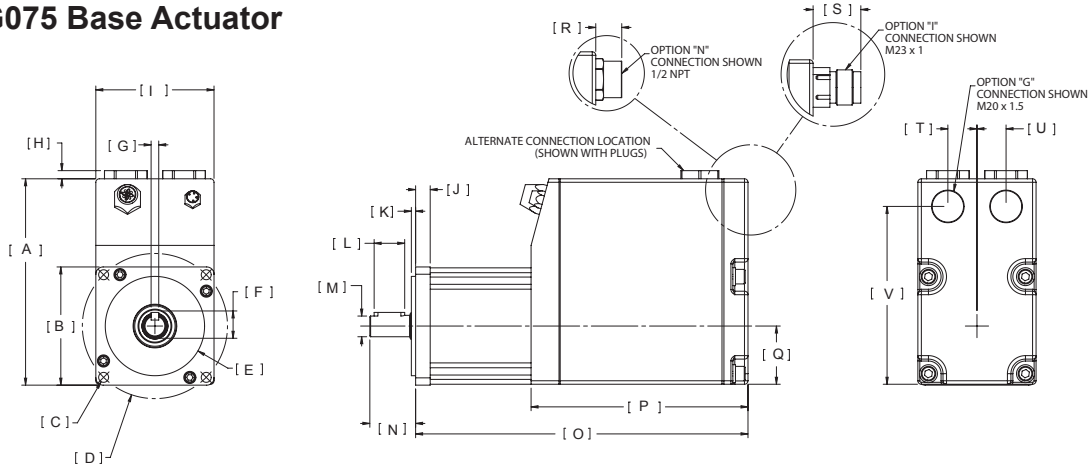

		R2M075	R2G075			R2M075	R2G075
A	in	5.32	5.32	L	in	0.79	0.79
	mm	135.1	135.1		mm	20.0	20.0
B	in	□ 3.05	□ 3.05	M	in	∅ 0.5512 / 0.5508	∅ 0.6302 / 0.6298
	mm	77.4	77.4		mm	14 h6	16 j6
C	in	4X ∅ 0.26 ON BC	4X ∅ 0.26 ON BC	N	in	1.18	1.18
	mm	6.5	6.5		mm	30.0	30.0
D	in	∅ 3.74 BC	∅ 3.74 BC	O	in	See Below	See Below
	mm	95.0	95.0		mm	See Below	See Below
E	in	∅ 2.5587 / 2.5580	∅ 2.5587 / 2.5580	P	in	5.59	5.59
	mm	65 g6	65 g6		mm	142.0	142.0
F	in	0.70	0.70	Q	in	1.50	1.50
	mm	17.9	17.9		mm	38.1	38.1
G	in	∅ 0.1969 / 0.1957	∅ 0.1969 / 0.1957	R	in	0.67	0.67
	mm	5 h9	5 h9		mm	17.0	17.0
H	in	0.21	0.21	S	in	1.23	1.23
	mm	5.3	5.3		mm	31.3	31.3
I	in	3.05	3.05	T	in	0.75	0.75
	mm	77.4	77.4		mm	19.1	19.1
J	in	0.38	0.45	U	in	0.75	0.75
	mm	9.5	11.5		mm	19.1	19.1
K	in	0.11	0.11	V	in	4.58	4.58
	mm	2.8	2.8		mm	116.4	116.4

R2M075

With Brake Option			
DIM	1 Stack Stator	2 Stack Stator	3 Stack Stator
O	9.85 (250.2)	10.85 (275.6)	11.85 (301.0)

Without Brake Option			
DIM	1 Stack Stator	2 Stack Stator	3 Stack Stator
O	8.57 (217.7)	9.57 (243.1)	10.57 (268.5)

R2G075

Without Brake Option			
DIM	1 Stack Stator 1 Stage Gearhead	2 Stack Stator 1 Stage Gearhead	3 Stack Stator 1 Stage Gearhead
O	10.19 (258.8)	11.19 (284.2)	12.19 (309.6)

With Brake Option			
DIM	1 Stack Stator 1 Stage Gearhead	2 Stack Stator 1 Stage Gearhead	3 Stack Stator 1 Stage Gearhead
O	11.42 (290.1)	12.42 (315.5)	13.42 (340.9)

Pre-sale drawings and models are representative and are subject to change. Certified drawings and models are available for a fee. Consult your local Exlar representative for details.

R2M/G090 Base Actuator

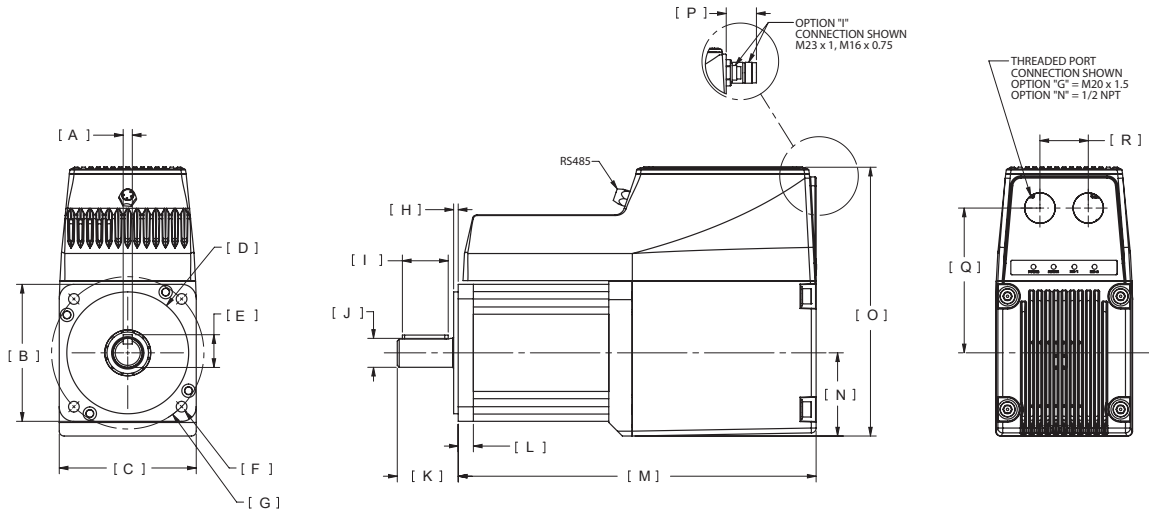

		R2M090	R2G090			R2M090	R2G090
A	in	0.2360 / 0.2348	0.2362 / 0.2350	J	in	Ø 0.7480 / 0.7475	Ø 0.8665 / 0.8659
	mm	6 h9	6 h9		mm	19 h6	22 j6
B	in	3.54	3.54	K	in	1.57	1.89
	mm	90	90		mm	40	48
C	in	3.54	3.54	L	in	0.39	0.63
	mm	90	90		mm	10	16
D	in	Ø 3.1492 / 3.1485	Ø 3.1492 / 3.1485	M	in	See Below	See Below
	mm	80 g6	80 g6		mm	See Below	See Below
E	in	0.85	0.96	N	in	2.15	2.15
	mm	21.5	24.5		mm	55	55
F	in	4X Ø 0.28 ON BC	4X Ø 0.257 ON BC	O	in	6.95	6.95
	mm	7	6.5		mm	177	177
G	in	Ø 3.94 BC	Ø 3.94 BC	P	in	1.30	1.30
	mm	100	100		mm	33	33
H	in	0.12	0.118	Q	in	3.74	3.74
	mm	3	3		mm	95	95
I	in	1.38	1.417	R	in	1.25	1.25
	mm	35	36		mm	32	32

R2M090

Without Brake Option		
DIM	2 Stack Stator	3 Stack Stator
M	10.25 (256.3)	11.25 (285.8)

With Brake Option		
DIM	2 Stack Stator	3 Stack Stator
M	11.6 (294.6)	12.6 (320.0)

R2G090

Without Brake Option		
DIM	2 Stack Stator 1 Stage Gearhead	3 Stack Stator 1 Stage Gearhead
M	12.36 (313.9)	13.36 (339.3)
DIM	2 Stack Stator 2 Stage Gearhead	3 Stack Stator 2 Stage Gearhead
M	13.63 (346.2)	14.63 (371.6)

With Brake Option		
DIM	2 Stack Stator 1 Stage Gearhead	3 Stack Stator 1 Stage Gearhead
M	13.67 (347.2)	14.67 (372.6)
DIM	2 Stack Stator 2 Stage Gearhead	3 Stack Stator 2 Stage Gearhead
M	14.94 (379.5)	15.94 (404.9)

Pre-sale drawings and models are representative and are subject to change. Certified drawings and models are available for a fee. Consult your local Exlar representative for details.

Tritex II AC Rotary

R2M/G115 Base Actuator

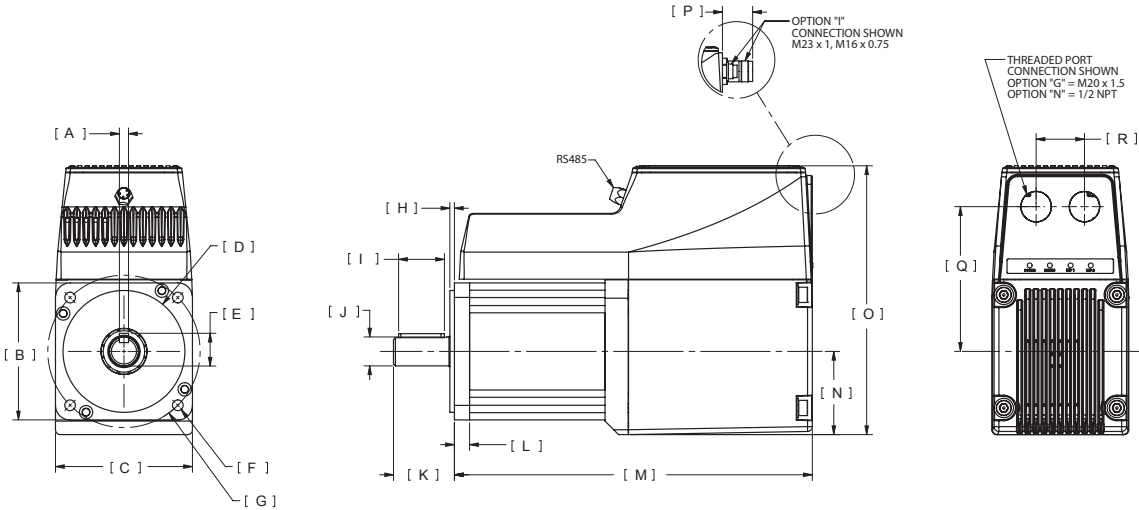

		R2M115	R2G115			R2M115	R2G115
A	in	0.3150 / 0.3135	0.3937 / 0.3923	J	in	Ø 0.9449 / 0.9444	Ø 1.2603 / 1.2596
	mm	8 h9	10 h9		mm	24 h6	32 j6
B	in	4.53	4.530	K	in	1.97	2.55
	mm	115	115		mm	50	65
C	in	4.53	4.530	L	in	0.45	0.64
	mm	115	115		mm	12	16
D	in	Ø 4.3302 / 4.3294	Ø 4.3302 / 4.3294	M	in	See Below	See Below
	mm	110 g6	110 g6		mm	See Below	See Below
E	in	1.06	1.380	N	in	2.27	2.27
	mm	27	35		mm	58	58
F	in	4 X Ø 0.34 ON BC	4 X Ø 0.34 ON BC	O	in	7.56	7.56
	mm	8.5	8.5		mm	192	192
G	in	Ø 5.12 BC	Ø 5.12 BC	P	in	1.30	1.30
	mm	130	130		mm	33	33
H	in	0.16	0.16	Q	in	4.23	4.23
	mm	4	4		mm	108	108
I	in	1.41	1.58	R	in	1.25	1.25
	mm	35.9	40		mm	32	32

R2M115

Without Brake Option		
DIM	1 Stack Stator	2 Stack Stator
M	9.87 (250.7)	11.87 (301.5)

With Brake Option		
DIM	1 Stack Stator	2 Stack Stator
M	11.60 (294.6)	13.60 (345.4)

R2G115

Without Brake Option		
DIM	1 Stack Stator 1 Stage Gearhead	2 Stack Stator 1 Stage Gearhead
M	13.88 (352.6)	15.88 (403.4)
DIM	1 Stack Stator 2 Stage Gearhead	2 Stack Stator 2 Stage Gearhead
M	15.49 (393.4)	17.49 (444.2)

With Brake Option		
DIM	1 Stack Stator 1 Stage Gearhead	2 Stack Stator 1 Stage Gearhead
M	15.43 (391.9)	17.43 (442.7)
DIM	1 Stack Stator 2 Stage Gearhead	2 Stack Stator 2 Stage Gearhead
M	17.04 (432.8)	19.04 (483.6)

Pre-sale drawings and models are representative and are subject to change. Certified drawings and models are available for a fee. Consult your local Exlar representative for details.

Tritex II AC Linear Ordering Guide

[Return to Table of Contents](#)

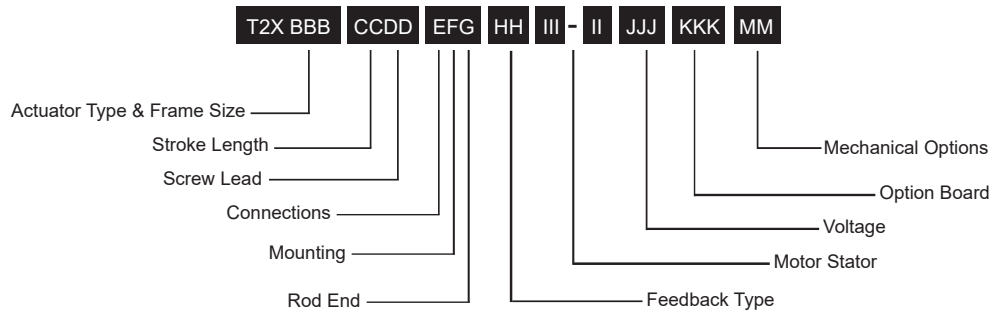

Actuator Type

T2X = Tritex II Linear Actuator, high mechanical capacity

BBB = Actuator Frame Size

075 = 75 mm
090 = 90 mm
115 = 115 mm

CC = Stroke Length

03 = 3 inch (76 mm) (N/A T2M/X115)
04 = 4 inch (102 mm) (T2M/X115 only)
06 = 6 inch (152 mm)
10 = 10 inch (254 mm)
12 = 12 inch (305 mm)
14 = 14 inch (356 mm)
18 = 18 inch (457 mm)

DD = Screw Lead (linear travel per screw revolution)

01 = 0.1 inch (2.54 mm)
02 = 0.2 inch (5.08 mm)
05 = 0.5 inch (12.7 mm)
08 = 0.75 inch (19.05 mm) (T2M/X115 only) ²

E = Connections

G = Standard Straight Threaded Port with Internal terminals, M20 x 1.5
N = NPT Threaded Port via Adapter with Internal Terminals, 1/2" NPT
I = Intercontec Style - Exlar std, M16/M23 Style Connector

F = Mounting

C = Rear Clevis
D = Double Side Mount
E = Extended Tie Rod
F = Front Flange
G = Metric Rear Clevis
K = Metric Double Side Mount
M = Metric Extended Tie Rod
Q = Metric Side Trunnion
R = Rear Flange
T = Side Trunnion

G = Rod End

A = Male Metric Thread ¹
B = Female Metric Thread ¹
F = Female US Standard Thread ¹
M = Male US Standard Thread ¹

HH = Feedback Type

HD = Analog Hall Device
IE = Incremental Encoder, 8192 count resolution
AF = Absolute Feedback

III-II = Motor Stator, All 8 Pole

T2X075 Stator Specifications
138-40 = 1 Stack, 230 VAC, 4000 rpm
238-30 = 2 Stack, 230 VAC, 3000 rpm
338-20 = 3 Stack, 230 VAC, 2000 rpm

T2X090 Stator Specifications

138-40 = 1 Stack, 230 VAC, 4000 rpm
238-40 = 2 Stack, 230 VAC, 4000 rpm
238-30 = 2 Stack, 230 VAC, 3000 rpm ⁶

T2X115 Stator Specifications

138-30 = 1 Stack, 230 VAC, 3000 rpm
238-20 = 2 Stack, 230 VAC, 2000 rpm ⁸
238-15 = 2 Stack, 230 VAC, 1500 rpm ^{6,8}
(N/A with 0.1" lead)

JJJ = Voltage

230 = 115-230 VAC, single phase

KKK = Option Board

SIO = Standard I/O Interconnect
IA4 = 4-20 mA Analog I/O
EIP = SIO plus Ethernet/IP w/M12 connector
EIN = SIO plus Ethernet/IP without M12 connector ⁷
PIO = SIO plus Profinet IO w/M12 connector
PIN = SIO plus Profinet IO without M12 connector ⁷
TCP = SIO plus Modbus TCP w/M12 connector
TCN = SIO plus Modbus TCP without M12 connector ¹⁰

MM = Mechanical Options ³

AR = External Anti-rotate
L1/2/3 = External Limit Switches ⁴
RB = Rear Brake
PB = Protective Bellows (N/A with extended tie rod mounting option)
SR = Splined Main Rod ⁵



For options or specials not listed above or for extended temperature operation, please contact Exlar

NOTES:

1. Chrome-plated carbon steel. Threads not chrome-plated.
2. 0.75 inch lead not available above 12 inch stroke.
3. For extended temperature operation consult factory for model number.

4. Limit switch option requires AR option.
5. This option is not sealed and is not suitable for any environment in which contaminants come in contact with actuator and may enter the actuator.

6. N/A with 0.1 inch lead
7. Requires customer supplied Ethernet cable through I/O port for Class 1 Division 2 compliance only.
8. Not available with 4 inch stroke.

Tritex II AC Rotary Ordering Guide

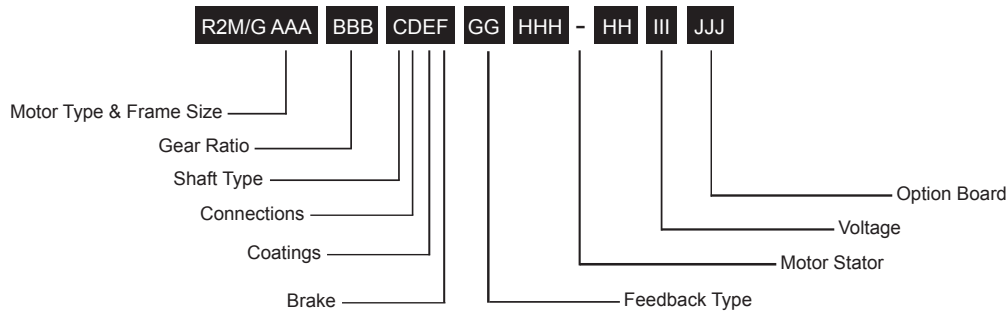

R2M/G = Motor Type

R2M = Tritex II AC Rotary Motor
R2G = Tritex II AC Rotary Gearmotor

AAA = Frame Size

075 = 75 mm
090 = 90 mm
115 = 115 mm

BBB = Gear Ratio

Blank = R2M
Single Reduction Ratios
004 = 4:1
005 = 5:1
010 = 10:1
Double Reduction Ratios (N/A on 75 mm)
016 = 16:1 020 = 20:1
025 = 25:1 040 = 40:1
050 = 50:1 100 = 100:1

C = Shaft Type

K = Keyed

D = Connections

G = Standard Straight Threaded Port with Internal Terminals, M20 x 1.5
N = NPT Threaded Port with Internal Terminals, 1/2" NPT
I = Intercontec style - Exlar Standard, M16/M23 Style Connector

E = Coating Options

G = Exlar Standard

F = Brake Option

S = No Brake, Standard
B = Electric Brake, 24 VDC

GG = Feedback Type

HD = Analog Hall Device
IE = Incremental Encoder, 8192 Count Resolution
AF = Absolute Feedback

HHH-HH = Motor Stators

R2M/G075 Stator Specifications
138-40 = 1 Stack, 230 VAC, 4000 rpm
238-30 = 2 Stack, 230 VAC, 3000 rpm
338-20 = 3 Stack, 230 VAC, 2000 rpm

R2M/G090 Stator Specifications
238-40 = 2 Stack, 230 VAC, 4000 rpm
238-30 = 2 Stack, 230 VAC, 3000 rpm
338-20 = 3 Stack, 230 VAC, 2000 rpm

R2M/G115 Stator Specifications
138-30 = 1 Stack, 230 VAC, 3000 rpm
238-20 = 2 Stack, 230 VAC, 2000 rpm
238-15 = 2 Stack, 230 VAC, 1500 rpm

III = Voltage

230 = 115-230 VAC, Single Phase

JJJ = Option Board

SIO = Standard I/O Interconnect
IA4 = 4-20 mA Analog I/O
EIP = SIO plus Ethernet/IP w/M12 connector
EIN = SIO plus Ethernet/IP without M12 connector¹
PIO = SIO plus Profinet IO w/M12 connector
PIN = SIO plus Profinet IO without M12 connector¹
TCP = SIO plus Modbus TCP w/M12 connector
TCN = SIO plus Modbus TCP without M12 connector¹



For options or specials not listed above or for extended temperature operation, please contact Exlar

NOTES:

- Requires customer supplied Ethernet cable through I/O port for Class 1 Division 2 compliance only.
- For extended temperature operation consult factory for model number.

Cable and Accessories

Tritex II AC Series Cable & Accessories	Part No.
Communications Accessories - Tritex uses a 4 pin M8 RS485 communications connector	
Recommended PC to Tritex communications cable-USB/RS485 to M8 connector - xxx = Length in feet, 006 or 015 only	CBL-T2USB485-M8-xxx
Multi-Drop RS485 Accessories	
RS485 splitter - M8 Pin plug to double M8 Socket receptacle	TT485SP
Multidrop Communications Cable M8 to M8 for use with TT485SP/RS485 splitter - xxx = Length in feet, 006 or 015 only	CBL-TTDAS-xxx
"G" Connection Accessories	
Nickel plated cable gland- M20 x 1.5 - CE shielding- 2 required	GLD-T2M20 x 1.5
Power cable prepared on one end for use with GLD-T2M20 x 1.5 xxx = Length in ft, Standard lengths 015, 025, 050, 075, 100	CBL-T2IPC-RAW-xxx
I/O cable prepared on one end for use with GLD-T2M20 x 1.5 xxx = Length in ft, Standard lengths 015, 025, 050, 075, 100	CBL-T2IOC-RAW-xxx
"N" Connection Accessories	
M20 x 1.5 to 1/2" NPT threaded hole adapter for use with conduit	ADAPT-M20-NPT1/2
"I" Connection	
Power cable with M23 6 pin xxx = Length in feet, std lengths 015, 025, 050, 075, 100	CBL-T2IPC-SMI-xxx
I/O cable (75 mm) with M23 19 pin xxx = Length in feet, std lengths 015, 025, 050, 075, 100	CBL-TTIOC-SMI-xxx
I/O cable (90 & 115 mm) with M16 19 pin xxx = Length in feet, std lengths 015, 025, 050, 075, 100	CBL-T2IOC-SMI-xxx
Multi-Purpose Communications Accessories for long runs, requires terminal block interconnections	
USB to RS485 convertor/cable - USB to RS485 flying leads - xxx = Length in feet, 006 or 015 only	CBL-T2USB485-xxx
Communications cable M8 to flying leads cable xxx = Length in feet, standard lengths 015, 025, 050, 075, 100	CBL-TTCOM-xxx
Option Board Cables and Accessories	
EIP, PIO and TCP option Ethernet cable - M12 to RJ45 cable xxx = Length in feet, std lengths 015, 025, 050, 075, 100.	CBL-T2ETH-R45-xxx
Electrical Accessories	
Dynamic Braking Resistor - 100W470hm	T2BR1
Replacement -AF Battery - used for absolute feedback option	T2BAT1
Replacement Normally Closed External Limit Switch (Turck Part number BIM-UNT-RP6X)	43404
Replacement Normally Open External Limit Switch (Turck Part number BIM-UNT-AP6X)	43403
Mechanical Accessories	
Clevis Pin for T2X090 male "M" rod end 1/2-20 thread	CP050
Clevis Pin for T2X115 male "M" rod end 3/4-16 thread	CP075
Spherical Rod Eye for T2X090 male "M" rod end 1/2-20 thread	SRM050
Spherical Rod Eye for T2X115 male "M" rod end 3/4-16 thread	SRM075
Rod Eye for T2X090 male "M" rod end 1/2-20 thread	REI050
Rod Eye for T2X115 male "M" rod end 3/4-16 thread	RE075
Rod Clevis for T2X090 male "M" rod end 1/2-20 thread	RCI050
Rod Clevis for T2X115 male "M" rod end 3/4-16 thread	RC075
Jam Nut for T2X090 male rod end, 1/2 - 20	JAM1/2-20-SS
Jam Nut for T2X115 male rod end, 3/4-16	JAM3/4-16-SS



CBL-T2USB485-M8-xxx
Our recommended communications cable. No special drivers or setup required for use with MS Windows™.



CBL-T2USB485-xxx
Use for terminal connections with CBL-TTCOM for long cable runs. No special drivers or setup required for use with MS Windows™.



CBL-TTIOC-SMI-xxx



CBL-TTIPC-SMI-xxx



CBL-TTCOM-xxx
Use with CBL-T2USB485-xxx for long cable runs.



CBL-TTDAS-xxx
For use with TT485SP for multi-drop applications.



TT485SP
RS485 communications splitter. Use to daisy-chain multiple Tritex actuators.

[Return to Table of Contents](#)

Tritex II DC

Linear & Rotary Actuators

No Compromising on Power, Performance or Reliability
 With forces to approximately 950 lbs (4kN) continuous and 1,300 lbf peak (6 kN), and speeds to 33 in/sec (800 mm/sec), the DC Tritex II linear actuators also offer a benefit that no other integrated product offers: POWER! No longer are you limited to trivial amounts of force, or speeds so slow that many motion applications are not possible. And the new Tritex II with DC power electronics operates with maximum reliability over a broad range of ambient temperatures: -40°C to +65°C. The DC powered Tritex II actuators contain a 750 W servo amplifier and a very capable motion controller. With standard features such as analog following for position, compound moves, move chaining, and individual force/torque control for each move, the Tritex II Series is the ideal solution for most motion applications.

Tritex II Models

- TDX high mechanical capacity actuator, 60, and 75 mm
- RDM rotary motor, 60, 75, and 90 mm
- RDG rotary gearmotor, 60, 75, and 90 mm

Power Requirements

- DC Power 12-48 VDC nominal
- Connections for external braking resistor

Feedback Types

- Analog Hall with 1000 count resolution
- Incremental encoder with 8192 count resolution
- Absolute Feedback (analog hall with multi-turn, battery backup)

Connectivity

- Internal terminals accessible through removable cover (75 and 90 mm models)
- Threaded ports for cable glands (75 and 90 mm models)
- Optional connectors - M23 Power - M23 I/O
- M8 connector for RS485
- M12 connector for EtherNet options
- Custom connection options
- Embedded leads

Technical Characteristics	
Frame Sizes in (mm)	2.3 (60), 2.9 (75)
Screw Leads in (mm)	0.1 (2), 0.2 (5), 0.4 (10), 0.5 (13)
Standard Stroke Lengths in (mm)	3 (76), 6 (152), 10 (254), 12 (305), 14 (356), 18 (457)
Force Range	up to 872 lbf (3879 N)
Maximum Speed	up to 33.3 in/s (846 mm/s)

Tritex II Linear DC Actuator



Tritex II Rotary Motor with Connectors

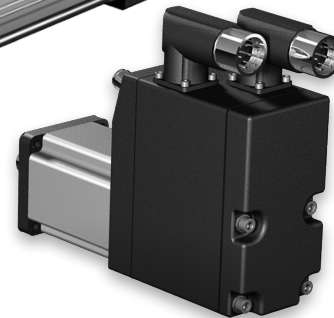

Tritex II Linear Actuator with Customer-supplied Cable Glands Ports

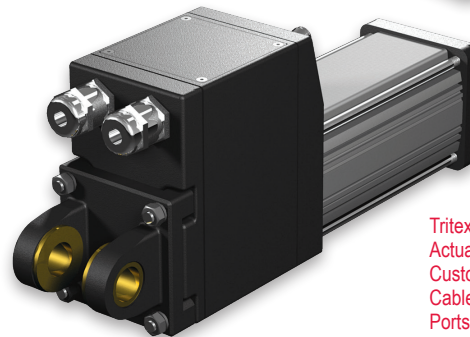

Operating Conditions and Usage		
Accuracy:		
Screw Lead Error	in/ft (μm / 300 mm)	0.001 (25)
Screw Travel Variation	in/ft (μm / 300 mm)	0.0012 (30)
Screw Lead Backlash	in	0.004 (TDX),
Ambient Conditions:		
Standard Ambient Temperature	°C	0 to 65
Extended Ambient Temperature**	°C	-40 to 65
Storage Temperature	°C	-40 to 85
IP Rating		TDX = IP66S RDM/RDG = IP66S
NEMA Ratings		None
Vibration		5.0 g rms, 5 to 500 hz

*Ratings at 40°C, operation over 40°C requires de-rating. See page 73.

**Consult Exlar for extended temperature operation.

Communications & I/O

Digital Inputs:

9 to 30 VDC Opto-isolated

Digital Outputs:

30 VDC maximum

100 mA continuous output

Isolated

Short circuit and over temperature protected

Analog Input DC:

0-10V or +/-10V

0-10V mode, 12 bit resolution

+/-10V mode, 13 bit resolution assignable to Position, Velocity, Torque, or Velocity override command

Analog Output DC:

0-10V

11 bit resolution

IA4 option:

4-20 mA input

16 bit resolution

Isolated

Assignable to Position, Velocity, Torque, or Velocity Override command

4-20 mA output

12 bit resolution

Assignable to Position, Velocity, Current, Temperature, etc.

Standard Communications:

- 1 RS485 port, Modbus RTU, opto-isolated for programming, controlling and monitoring

Tritex II DC I/O		
	60/75/90 mm frame with SIO, EIP, PIO, TCP	60/75/90 mm frame with IA4
Isolated digital inputs	8	4
Isolated digital outputs	4	3
Analog input, non isolated	1	0
Analog output, non isolated	1	0
Isolated 4-20ma input	0	1
Isolated 4-20ma output	0	1

The IO count and type vary with the actuator model and option module selected.

All models include isolated digital IO, and an isolated RS485 communication port when using Modbus RTU protocol.

Product Features

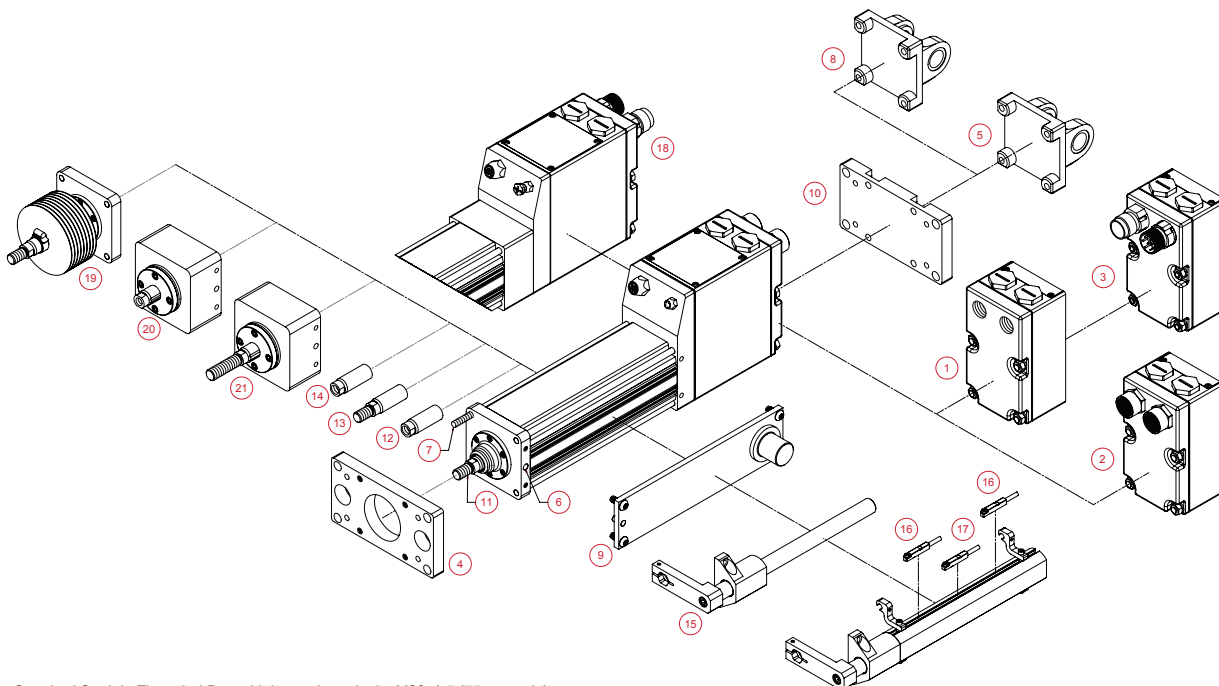
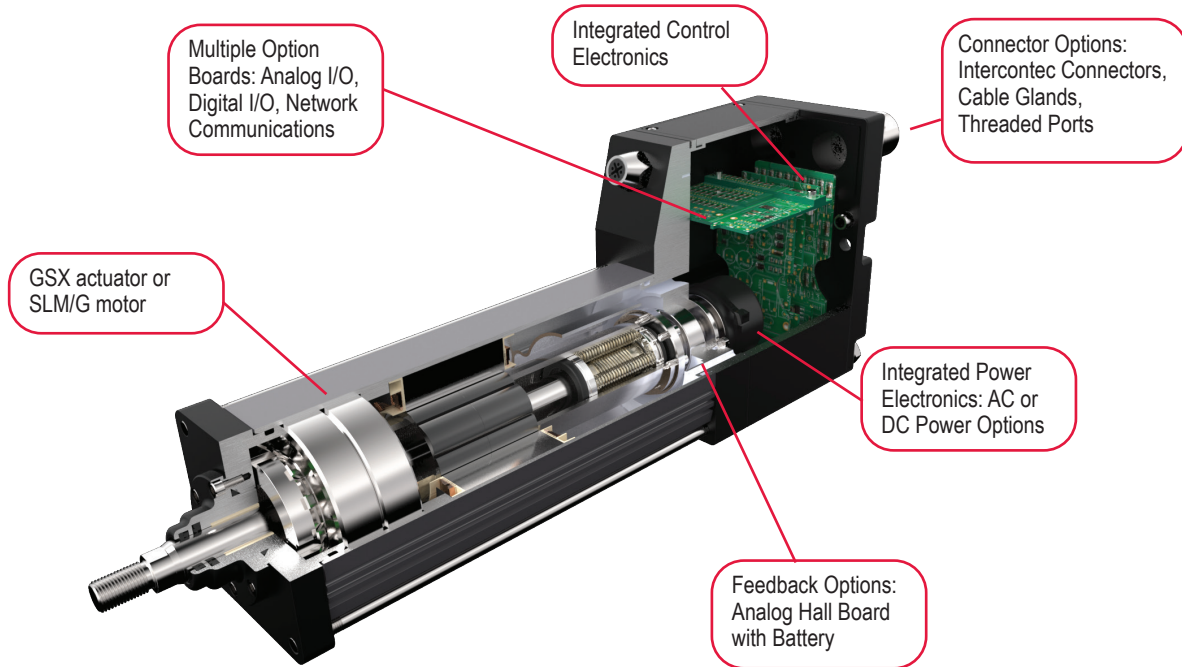

- 1 - Standard Straight Threaded Port with internal terminals, M20x1.5 (75 mm only)
- 2 - NPT Threaded Port via Adapter with Internal Terminals, 1/2" NPT (75 mm only)
- 3 - Interconnect Style - Exlar standard, M23 Style Connector
- 4 - Front Flange
- 5 - Rear Clevis
- 6 - Double Side Mount and Metric Double Side Mount
- 7 - Extended Tie Rod and Metric Extended Tie Rod
- 8 - Metric Rear Clevis
- 9 - Metric Side Trunnion and Side Trunnion
- 10 - Female Metric Thread
- 11 - Male Metric Thread
- 12 - Female Metric Thread
- 13 - Male US Standard Thread
- 14 - Female US Standard Thread
- 15 - External Anti-rotate
- 16 - External Limit Switch - N.C., PNP
- 17 - External Limit Switch - N.O., PNP
- 18 - Rear Brake
- 19 - Protective Bellows
- 20 - Splined Main Rod - Female
- 21 - Splined Main Rod - Male

[Return to Table of Contents](#)

Industries and Applications

Hydraulic cylinder replacement
Ball screw replacement
Pneumatic cylinder replacement

Process Control

Oil & Gas Wellhead Valve Control
Pipeline Valve Control
Damper Control
Knife Valve Control
Chemical pumps

Entertainment / Simulation

Ride Motion Bases
Animatronics

Mobile Equipment

Unmanned Vehicles

Since no fluids and associated equipment (pumps, compressors, filters, accumulators, hose/tubing, oil testing, etc.) are required, electromechanical actuators offer greater energy efficiency, less environmental impact and lower total life-cycle cost.

The Tritex II Series DC actuators integrate a DC powered servo drive, digital position controller, brushless motor, and linear actuator in a compact, sealed package making it perfect for environments where AC power is difficult to achieve.

Mechanical Specifications

TDX060

	Stator	1 Stack	2 Stack	3 Stack	
Lead	RPM @ 48 VDC	5000	5000	4000	
0.1	Continuous Force	lbf (N)	339 (1508)	528 (2349)	N/A
	Peak Force	lbf (N)	641 (2851)	666 (2963)	N/A
	Max Speed @ 48 VDC	in/sec (mm/sec)	8.33 (211.6)	8.33 (211.6)	N/A
	TDX - C _a (Dynamic Load Rating)	lbf (N)	2075 (9230)		NA
0.2	Continuous Force	lbf (N)	180 (801)	280 (1246)	347 (1544)
	Peak Force	lbf (N)	340 (1512)	354 (1575)	454 (2019)
	Max Speed @ 48 VDC	in/sec (mm/sec)	16.67 (423.4)	16.67 (423.4)	13.33 (338.6)
	TDX - C _a (Dynamic Load Rating)	lbf (N)	1540 (6850)		
0.4	Continuous Force	lbf (N)	95 (423)	148 (658)	184 (818)
	Peak Force	lbf (N)	180 (801)	187 (832)	240 (1068)
	Max Speed @ 48 VDC	in/sec (mm/sec)	33.33 (847)	33.33 (847)	26.67 (677.4)
	TDX - C _a (Dynamic Load Rating)	lbf (N)	1230 (5471)		
Drive Current @ Continuous Force	Amps	14.75	21.5	21.5	
Available Stroke Lengths	in (mm)	3 (75), 6 (150), 10 (254), 12 (300)			
Inertia (zero stroke)	lb-in-s ² / Kg-m ²	0.0007758 (0.0000008766)	0.0008600 (0.0000009717)	0.0009442 (0.000001067)	
Inertia Adder (per unit of stroke)	lb-in-s ² /in/ Kg-m ² /in	0.00004667 (0.0000005273)			
Approximate Weight	lb (kg)	4 lbs – 3 in stroke, 1 stack, add 1 lb per inch of stroke, add 3 lbs per stack, add 3 lbs for brake. (1.8 kg – 75 mm stroke, 1 stack, add 0.5 kg per 25 mm of stroke, add 1.4 kg per stack, add 1.4 kg for brake.)			
Operating Temperature Range**		-20 to 65° C (-40° C available, consult Exlar)			
Maximum Continuous Power Supply Current†	Amps	11	15	15	

†Power supply current is based on software current limit, not thermal limit. Consideration for peak current should also be considered when sizing power supplies.

**Rating based on 40° C ambient conditions.

TDX075

		Stator	1 Stack	2 Stack	3 Stack
Lead		RPM @ 48 VDC	3000	3000	2000
0.1	Continuous Force	lbf (N)	613 (2727)	872 (3879)	NA
	Peak Force	lbf (N)	884 (3932)	1190 (5293)	NA
	Max Speed @ 48 VDC	in/sec (mm/sec)	5.00 (127)	5.00 (127)	NA
	TDX - C _s (Dynamic Load Rating)	lbf (N)	5516 (24536)		NA
0.2	Continuous Force	lbf (N)	347 (1544)	494 (2197)	774 (3443)
	Peak Force	lbf (N)	501 (2229)	674 (2998)	1095 (4871)
	Max Speed @ 48 VDC	in/sec (mm/sec)	10.00 (254)	10.00 (254)	6.67 (169.4)
	TDX - C _s (Dynamic Load Rating)	lbf (N)	5800 (25798)		
0.5	Continuous Force	lbf (N)	147 (654)	209 (930)	328 (1459)
	Peak Force	lbf (N)	212 (943)	286 (1272)	464 (2064)
	Max Speed @ 48 VDC	in/sec (mm/sec)	25.00 (635)	25.00 (635)	16.67 (423.4)
	TDX - C _s (Dynamic Load Rating)	lbf (N)	4900 (21795)		
Drive Current @ Continuous Force	Amps	18.5	22.5	22.5	
Available Stroke Lengths	in (mm)	3 (75), 6 (150), 10 (254), 12 (300), 14 (355), 18 (450)			
Inertia (zero stroke)	lb-in-s ² / Kg-m ²	0.01132 (0.000012790)	0.01232 (0.00001392)	0.01332 (0.00001505)	
Inertia Adder (per unit of stroke)	lb-in-s ² /in/ Kg-m ² /in	0.0005640 (0.0000006372)			
Approximate Weight	lb (kg)	11 lbs – 3 in stroke, add 1 lb per inch of stroke, add 3 lbs per stack, add 3 lbs for brake. (5 kg – 75 mm stroke, 1 stack, add 0.5 kg per 25 mm of stroke, add 1.4 kg per stack, add 1.4 kg for brake.)			
Operating Temperature Range**		-20 to 65° C (-40° C available, consult Exlar)			
Maximum Continuous Power Supply Current*	Amps	15	18	18	

*Power supply current is based on software current limit, not thermal limit. Consideration for peak current should also be considered when sizing power supplies.

**Rating based on 40° C ambient conditions.

DEFINITIONS:

Continuous Force: The linear force produced by the actuator at continuous motor torque.

Peak Force: The linear force produced by the actuator at peak motor torque.

Max Speed: The maximum rated speed produced by the actuator at rated voltage.

C_s (Dynamic Load Rating): A design constant used in calculating the estimated travel life of the roller screw.

Estimated Service Life

TDX060 Estimated L_{10} Travel Life

TDX075 Estimated L_{10} Travel Life

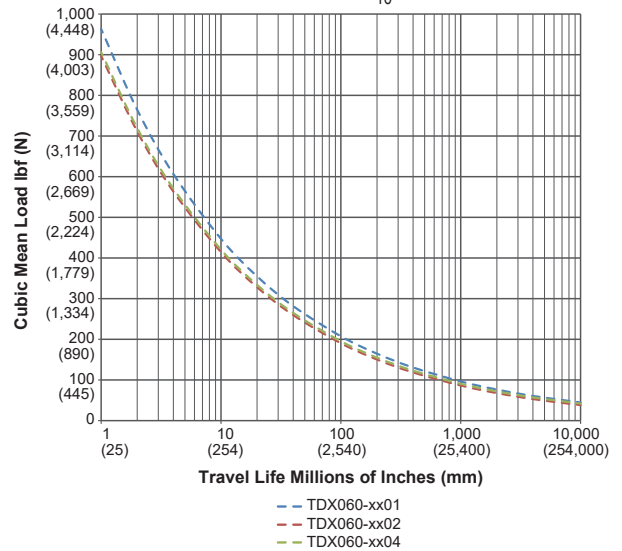

The L_{10} expected life of a roller screw linear actuator is expressed as the linear travel distance that 90% of properly maintained roller screws are expected to meet or exceed. For higher than 90% reliability, the result should be multiplied by the following factors: 95% x 0.62; 96% x 0.53; 97% x 0.44; 98% x 0.33; 99% x 0.21. This is not a guarantee; these charts should be used for estimation purposes only.

The underlying formula that defines this value is:

Travel life in millions of inches, where:

C_a = Dynamic load rating (lbf)

F_{cml} = Cubic mean applied load (lbf)

l = Roller screw lead (inches)

$$L_{10} = \left(\frac{C_a}{F_{cml}} \right)^3 \times l$$

All curves represent properly lubricated and maintained actuators.

Speed vs. Force Curves

Temperature Derating

The speed/torque curves are based on 40° C ambient conditions. The actuators may be operated at ambient temperatures up to 65° C. Use the curve (shown right) for continuous torque/force deratings above 40° C.

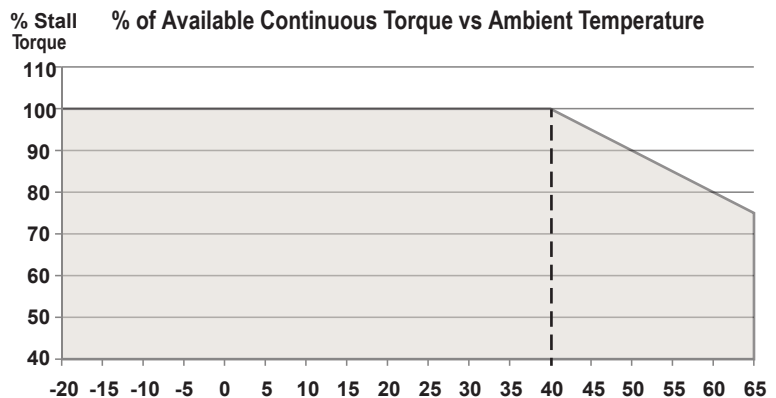

Tritex II DC Linear

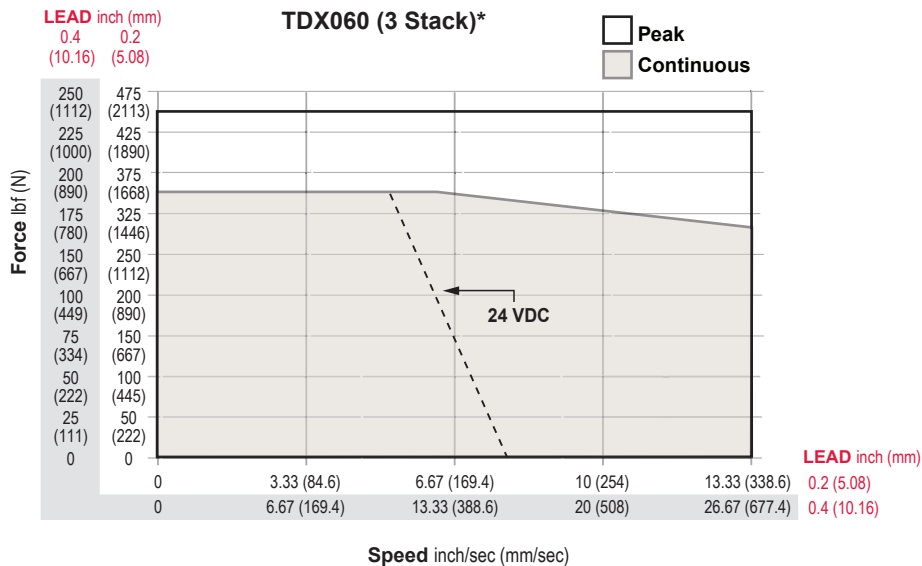
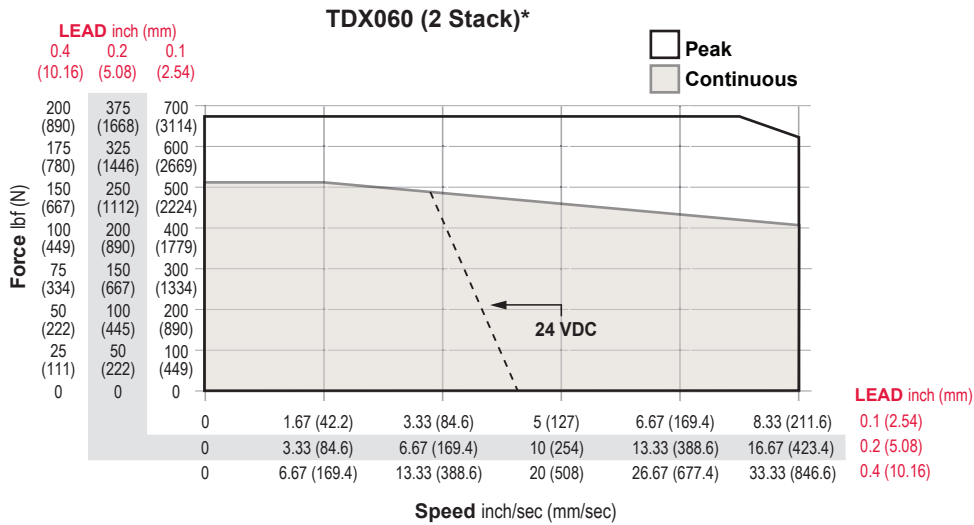
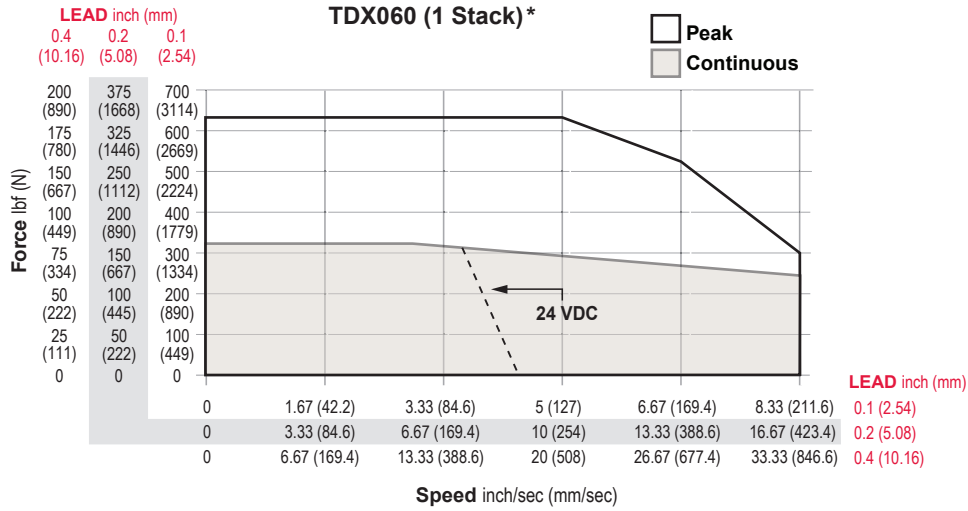

*Test data derived using NEMA recommended aluminum heatsink 10" x 10" x 3/8" at 40°C ambient.

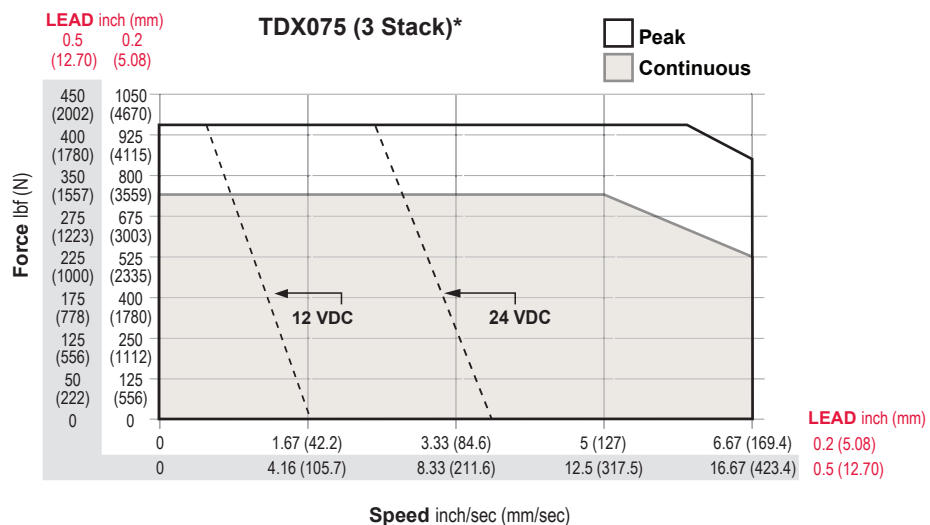
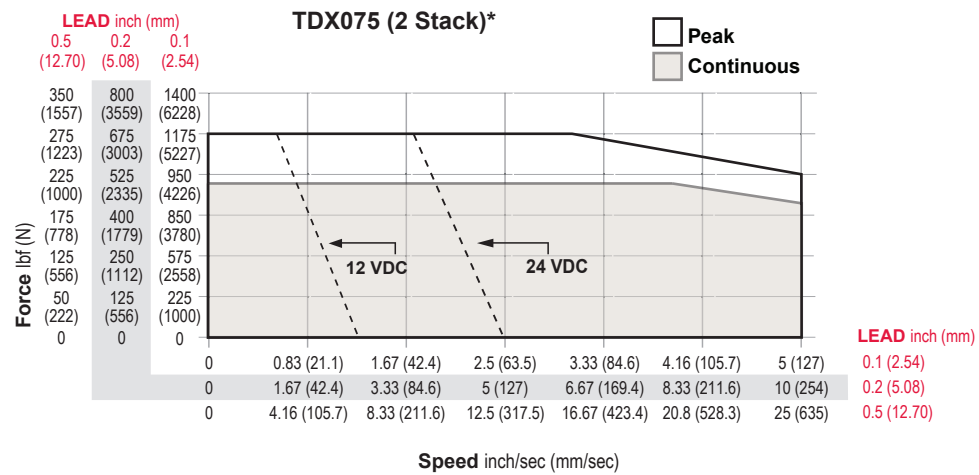
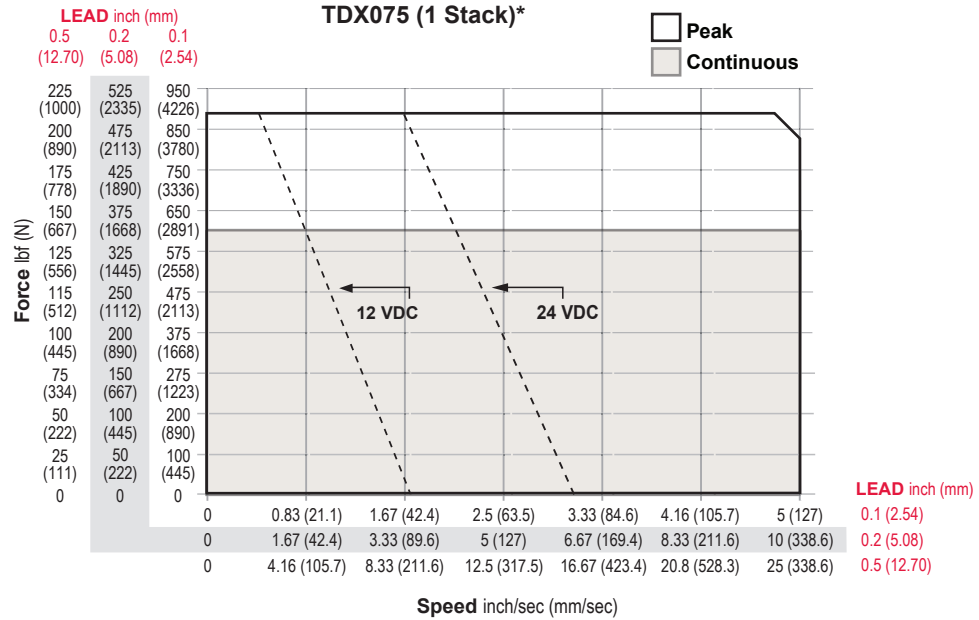

*Test data derived using NEMA recommended aluminum heatsink 10" x 10" x 3/8" at 40°C ambient.

Options

AR = External Anti-rotate Assembly

This option provides a rod and bushing to restrict the actuator rod from rotating when the load is not held by another method. Shorter actuators have single sided anti-rotation attachments. Longer lengths require attachments on both sides for proper operation. For AR dimensions, see page 79.

L1, L2, L3 = Adjustable External Travel Switches

This option allows up to 3 external switches to be included. These switches provide travel indication to the controller and are adjustable. See drawing on page 29. Must purchase external anti-rotate with this option.

RB = Rear Electric Brake

This option provides an internal holding brake. The brake is spring activated and electrically released.

PB = Protective Bellows

This option provides an accordion style protective bellows to protect the main actuator rod from damage due to abrasives or other contaminants in the environment in which the actuator must survive. The standard material of this bellows is S2 Neoprene Coated Nylon, Sewn Construction. This standard bellows is rated for environmental temperatures of -40 to 250 degrees F. Longer strokes may require the main rod of the actuator to be extended beyond standard length. Not available with extended tie rod mounting option. Please contact your local sales representative.

SR = Splined Main Rod

A ball spline shafting main rod with a ball spline nut that replaces the standard front seal and bushing assembly. This rod restricts rotation without the need for an external mechanism. The rod diameter will be the closest metric equivalent to our standard rod sizes. Since this option is NOT sealed, it is not suitable for environments in which contaminants may enter the actuator.

Note: Adding this option affects the overall length and mounting dimensions.

Dimensions

TDX060 Double Side Mount or Extended Tie Rod Mount

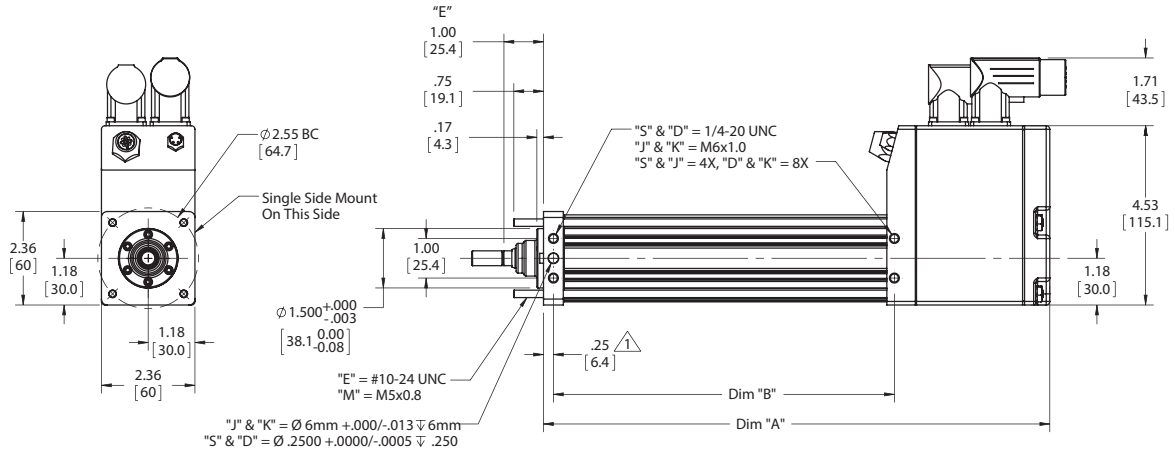

TDX060 Side Trunnion Mount or Rear Clevis Mount

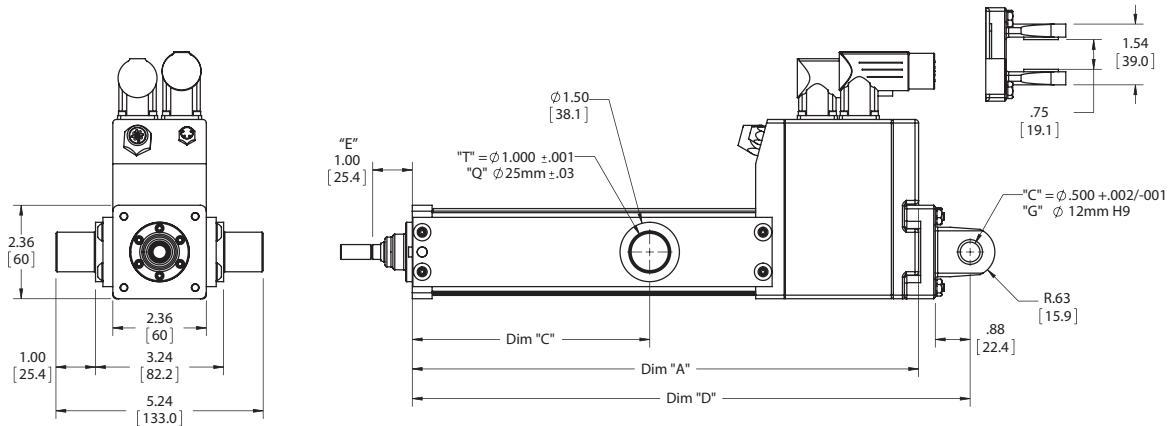

TDX060 Front, Rear, or Front and Rear Flange Mount

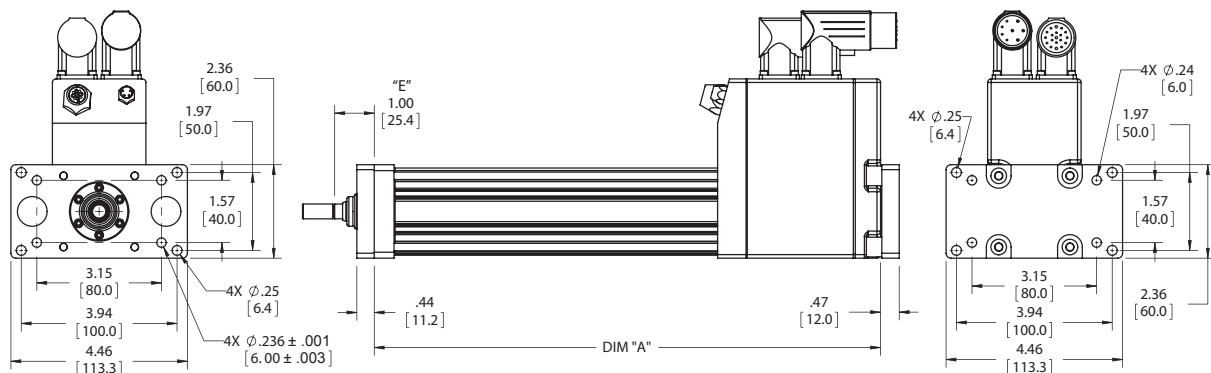

DIM	3 inch (75 mm) stroke in (mm)	6 inch (150 mm) stroke in (mm)	10 inch (250 mm) stroke in (mm)	12 inch (300 mm) stroke in (mm)
A	9.79 (248.7)	12.79 (324.9)	16.79 (426.5)	18.79 (477.3)
B	5.62 (142.8)	8.62 (218.9)	12.62 (320.6)	14.62 (371.4)
C	3.00 (76.2)	6.00 (152.4)	10.00 (254.0)	12.00 (304.8)
D	11.10 (281.9)	14.10 (358.1)	18.10 (459.7)	20.10 (510.5)

* Add 1.75 inches to dimensions "A", "B" and "D" if ordering a brake. Add .50 inches to dimensions "A", "C" and "D" and dimension if ordering a splined Δ main rod.

**Add 2 inches (50.8 mm) to "E" if ordering protective bellows.

Pre-sale drawings and models are representative and are subject to change. Certified drawings and models are available for a fee. Consult your local Exlar representative for details.

TDX075 Double Side Mount or Extended Tie Rod Mount

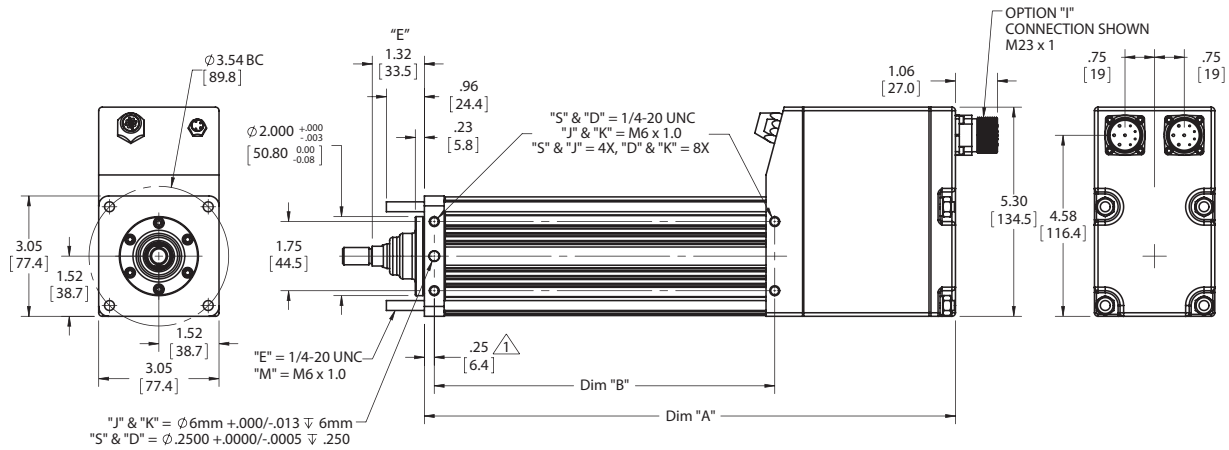

TDX075 Side Trunnion Mount or Rear Clevis Mount

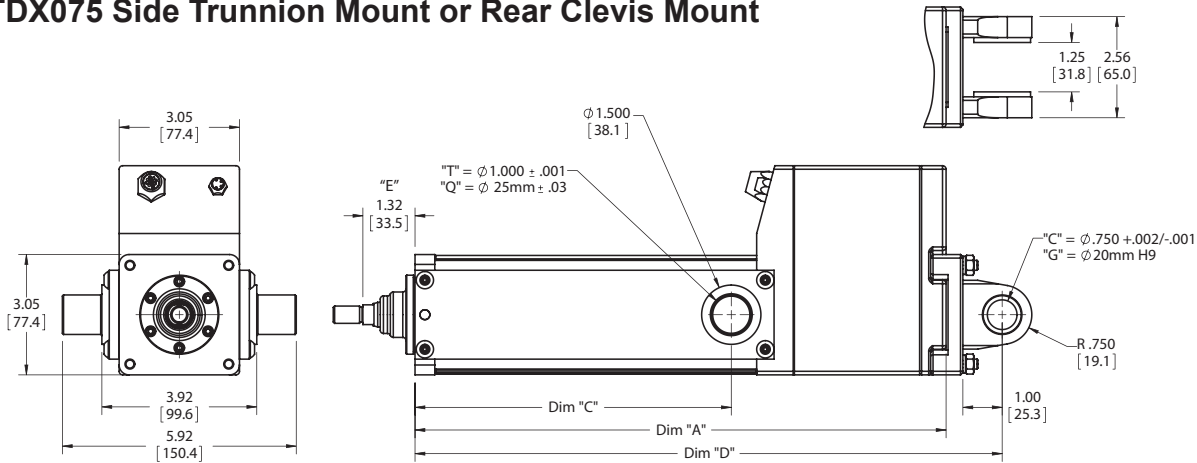

TDX075 Front, Rear, or Front and Rear Flange Mount

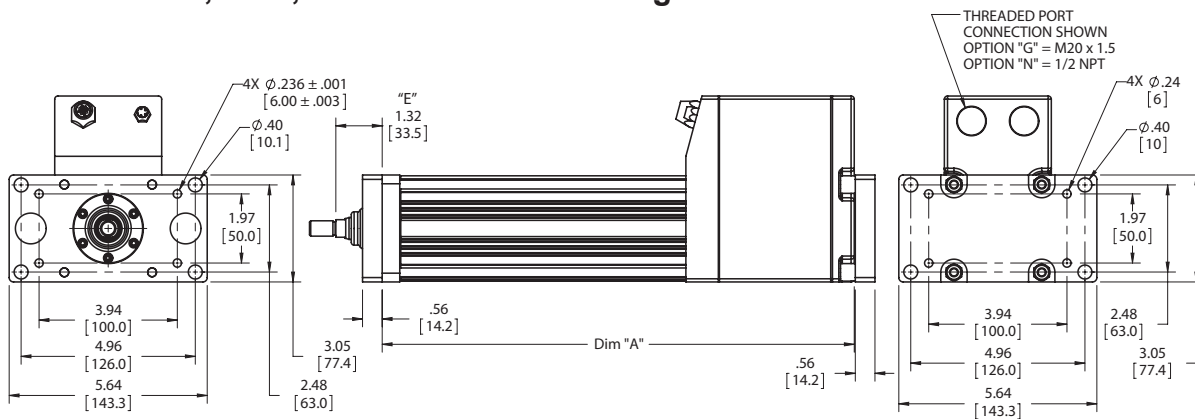

DIM	3 inch (75 mm) stroke in (mm)	6 inch (150 mm) stroke in (mm)	10 inch (250 mm) stroke in (mm)	12 inch (300 mm) stroke in (mm)	14 inch (350 mm) stroke in (mm)	18 inch (450 mm) stroke in (mm)
A	10.98 (278.9)	13.45 (341.6)	17.95 (455.9)	19.95 (506.7)	21.95 (557.5)	25.95 (659.1)
B	6.15 (156.2)	8.62 (218.9)	13.12 (333.2)	15.12 (384.0)	17.12 (434.8)	21.12 (536.4)
C	5.38 (136.7)	8.00 (203.2)	10.00 (254.0)	12.00 (304.8)	14.00 (355.6)	18.00 (457.2)
D	12.40 (315.0)	14.87 (377.7)	19.37 (492.0)	21.37 (542.8)	23.37 (593.6)	27.37 (695.2)

* Add 1.61 inches to dimensions "A", "B" and "D" if ordering a brake. Add 1.2 inches to dimensions "A", "C" and "D" and dimension if ordering a splined Δ main rod.

** Add 2 inches (50.8 mm) to "E" if ordering protective bellows.

Pre-sale drawings and models are representative and are subject to change. Certified drawings and models are available for a fee. Consult your local Exlar representative for details.

Anti-Rotate Option

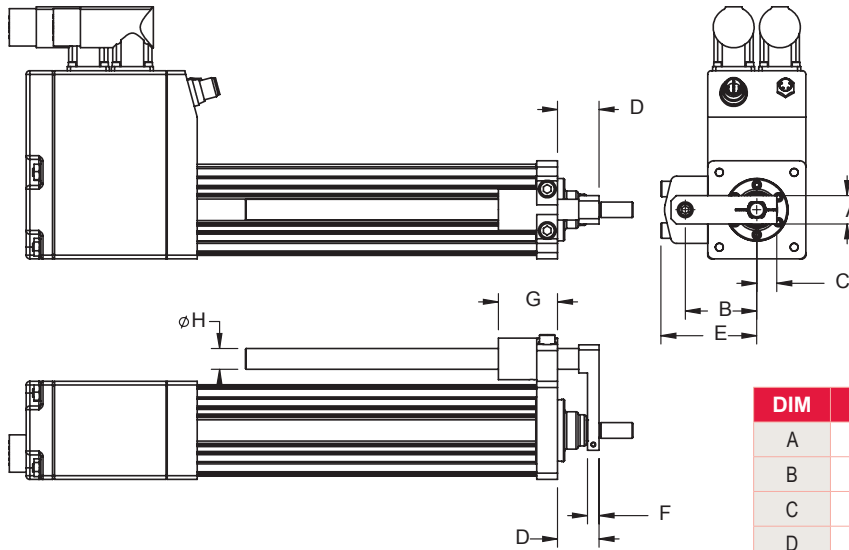

DIM	TDX060	TDX075
A	0.68 (17.3)	0.82 (20.9)
B	1.72 (43.7)	2.21 (56.1)
C	0.48 (12.2)	0.60 (15.2)
D	1.00 (25.4)	1.32 (33.5)
E	2.31 (58.7)	2.71 (68.8)
F	0.28 (7.1)	0.39 (9.9)
G	1.43 (36.3)	1.70 (43.2)
ØH	0.50 (12.7)	0.63 (15.9)

Actuator Rod End Option

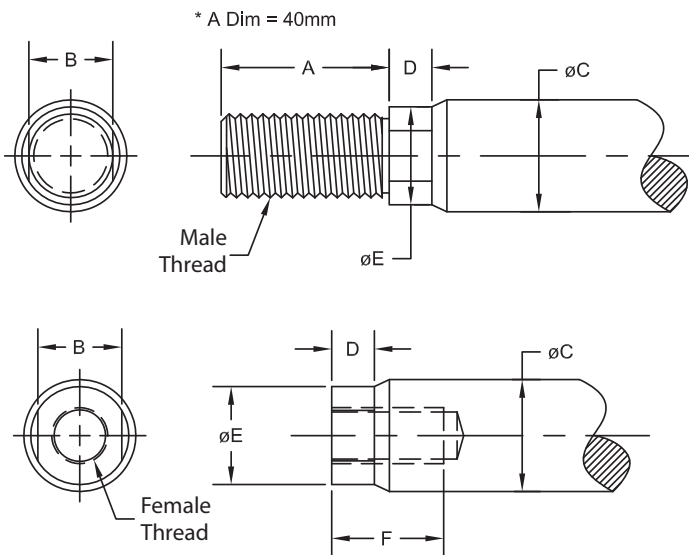

DIM	TDX060	TDX075
A	0.813 (20.7)	0.750 (19.1)
B	0.375 (9.5)	0.500 (12.7)
ØC	0.500 (12.7)	0.625 (15.9)
D	0.200 (5.1)	0.281 (7.1)
ØE	0.440 (11.2)	0.562 (14.3)
F	0.750 (19.1)	0.750 (19.1)
Male-Inch	3/8-24 UNF-2A	7/16-20 UNF-2A
Male-Metric	M8 x 1-6g	M12 x 1.75-6g [*]
Female-Inch	5/16-24 UNF-2B	7/16-20 UNF-2B
Female-Metric	M8 x 1-6h	M10 x 1.5-6h

^{*}When ordering the male M12x1.75 main rod for the TDM/X075 dimension "A" will be 1.57 in (40 mm)

Clevis Pin

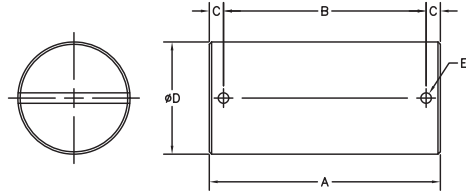

DIM	TDX060	TDX075
	CP050 in (mm) Rear Clevis, RE050 & RC050	CP075 in (mm) Rear Clevis
A	2.28 (57.9)	3.09 (78.5)
B	1.94 (49.28)	2.72 (69.1)
C	0.17 (4.32)	1.19 (4.82)
ØD	0.50 (12.7) -0.001/-0.002	0.75 (19.1) -0.001/-0.002
ØE	0.095 (2.41)	0.14 (3.56)

Spherical Rod Eye

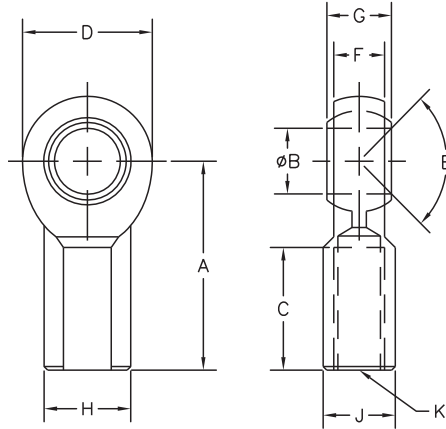

DIM	TDX060	TDX075
	SRM038 in (mm)	SRM044 in (mm)
A	1.625 (41.3)	1.81 (46.0)
ØB	0.375 (9.525)	0.438 (11.13)
C	0.906 (23.0)	1.06 (26.9)
D	1.0 (25.6)	1.13 (28.7)
E	12 Deg	14 Deg
F	0.406 (10.3)	0.44 (11.1)
G	0.500 (12.7)	0.56 (14.2)
H	0.688 (17.7)	0.75 (19.1)
J	0.562 (14.3)	0.63 (16.0)
K	3/8-24	7/16-20

Rod Eye

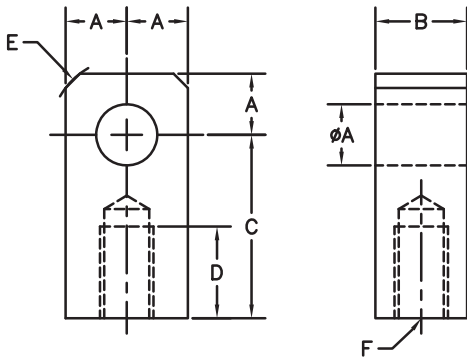

DIM	TDX060	TDX075
	RE038 in (mm)	RE050 in (mm)
ØA	0.50 (12.7)	0.50 (12.7)
B	0.560 (14.2)	0.75 (19.1)
C	1.000 (25.4)	1.50 (38.1)
D	0.500 (12.7)	0.75 (19.1)
E	0.25 x 45 (6.35)	0.63 (15.9)
F	3/8-24	7/16-20

Rod Clevis

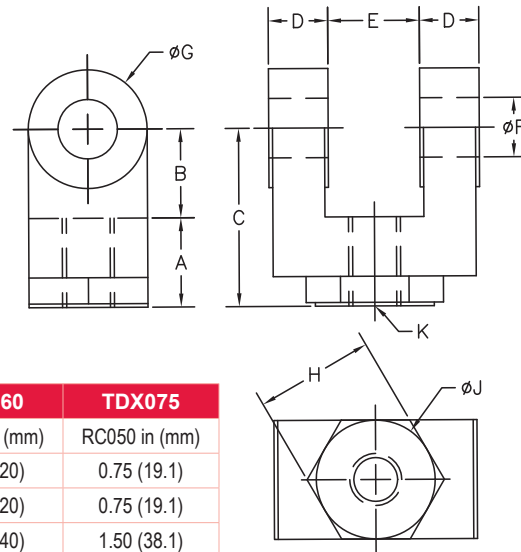

DIM	TDX060	TDX075
	RC038 in (mm)	RC050 in (mm)
A	0.787 (20)	0.75 (19.1)
B	0.787 (20)	0.75 (19.1)
C	1.574 (40)	1.50 (38.1)
D	0.183 (4.65)	0.50 (12.7)
E	0.375 (9.5)	0.765 (19.43)
ØF	0.375 (9.5)	0.50 (12.7)
ØG	0.75 (19.1)	1.00 (25.4)
H	N/A	1.00 (25.4)
ØJ	N/A	1.00 (25.4)
K	3/8-24	7/16-20

[Return to Table of Contents](#)

Mechanical Specifications

RDM/G060

Rotary Motor Torque and Speed Ratings				
	Stator	1 Stack	2 Stack	3 Stack
	RPM at 48 VDC	5000	5000	4000
Continuous Torque	lbf-in (Nm)	6.8 (0.76)	10.5 (1.18)	13 (1.47)
Peak Torque	lbf-in (Nm)	12.8 (1.44)	13.3 (1.5)	17 (1.92)
Drive Current @ Continuous Torque	Amps	14.8	21.5	21.5
Operating Temperature Range**	-20 to 65° C (-40° C available, consult Exlar)			
Maximum Continuous Power Supply Current*	Amps	8	11	13

*Power supply current is based on software current limit, not thermal limit. Consideration for peak current should also be considered when sizing power supplies. For output torque of RDG gearmotors, multiply by ratio and efficiency. Please note maximum allowable output torques found at bottom of page.

**Ratings based on 40° C ambient conditions.

Inertia				
	Stator	1 Stack	2 Stack	3 Stack
RDM Motor Armature Inertia (+/-5%)	lbf-in-sec ² (kg-cm ²)	0.000237 (0.268)	0.000413 (0.466)	0.000589 (0.665)
RDG Gearmotor Armature Inertia*	lbf-in-sec ² (kg-cm ²)	0.000226 (0.255)	0.000401 (0.453)	0.000576 (0.651)

*Add armature inertia to gearing inertia for total inertia.

L ₁₀ Radial Load and Bearing Life						
RPM	50	100	250	500	1000	3000
RDM060 lbf (N)	250 (1112)	198 (881)	148 (658)	116 (516)	92 (409)	64 (285)
RDG060 lbf (N)	189 (841)	150 (667)	110 (489)	88 (391)	70 (311)	48 (214)

Side load ratings shown above are for 10,000 hour bearing life at 25 mm from motor face at given rpm.

Gearmotor Mechanical Ratings					
Model	Ratio	Maximum Allowable Output Torque-Set by User lbf-in (Nm)	Output Torque at Motor Speed for 10,000 Hour Life		
			1000 RPM lbf-in (Nm)	3000 RPM lbf-in (Nm)	5000 RPM lbf-in (Nm)
RDG060-004	4:1	603 (68.1)	144 (16.2)	104 (11.7)	88 (9.9)
RDG060-005	5:1	522 (58.9)	170 (19.2)	125 (14.1)	105 (11.9)
RDG060-010	10:1	327 (36.9)	200 (22.6)	140 (15.8)	120 (13.6)
RDG060-016	16:1	603 (68.1)	224 (25.3)	160 (18.1)	136 (15.4)
RDG060-020	20:1	603 (68.1)	240 (27.1)	170 (19.2)	146 (16.5)
RDG060-025	25:1	522 (58.9)	275 (31.1)	200 (22.6)	180 (20.3)
RDG060-040	40:1	603 (68.1)	288 (32.5)	208 (23.5)	180 (20.3)
RDG060-050	50:1	522 (58.9)	340 (38.4)	245 (27.7)	210 (23.7)
RDG060-100	100:1	327 (36.9)	320 (36.1)	280 (31.6)	240 (27.1)

Two torque ratings for the RDG gearmotors are given in the table above. The left hand columns give the maximum (peak) allowable output torque for the indicated ratios of each size RDG gearmotor. This is not the rated output torque of the motor multiplied by the ratio of the reducer.

It is possible to select a configuration of the motor selection and gear ratio such that the rated motor torque, multiplied by the gear ratio exceeds these ratings. It is the responsibility of the user to ensure that the settings of the system do not allow these values to be exceeded.

The right hand columns give the output torque at the indicated speed which will result in 10,000 hour life (L10). The setup of the system will determine the actual output torque and speed.

Gearing Reflected Inertia					
Single Reduction			Double Reduction		
Gear Stages	lbf-in-sec ²	(kg-cm ²)	Gear Stages	lbf-in-sec ²	(kg-cm ²)
4:1	0.0000132	(0.149)	16:1	0.0000121	(0.0137)
5:1	0.0000087	(0.00984)	20:1, 25:1	0.0000080	(0.00906)
10:1	0.0000023	(0.00261)	40:1, 50:1, 100:1	0.0000021	(0.00242)

Backlash and Efficiency		
	Single Reduction	Double Reduction
Backlash at 1% Rated Torque	10 Arc min	13 Arc min
Efficiency	91%	86%

Motor and Gearmotor Weights				
	RDM060 without Gears	RDG060 with 1 Stage Gearing	RDG060 with 2 Stage Gearing	Added Weight for Brake
1 Stack Stator lb (kg)	3.0 (1.4)	7.5 (3.4)	9.3 (4.2)	0.6 (0.3)
2 Stack Stator lb (kg)	4.1 (1.9)	8.6 (3.9)	10.4 (4.7)	
3 Stack Stator lb (kg)	5.2 (2.4)	9.7 (4.4)	11.5 (5.2)	

RDM/G075

Rotary Motor Torque and Speed Ratings				
	Stator	1 Stack	2 Stack	3 Stack
	RPM at 48 VDC	4000	3000	2000
Continuous Torque	lbf-in (Nm)	13 (1.46)	18.5 (2.09)	29 (3.28)
Peak Torque	lbf-in (Nm)	18.9 (2.08)	28 (3.16)	41 (4.63)
Drive Current @ Continuous Torque	Amps	22	22	22
Operating Temperature Range**	-20 to 65° C (-40° C available, consult Exlar)			
Maximum Continuous Power Supply Current†	Amps	15	18	18

*Power supply current is based on software current limit, not thermal limit. Consideration for peak current should also be considered when sizing power supplies. For output torque of RDG gearmotors, multiply by ratio and efficiency. Please note maximum allowable output torques shown below.

**Ratings based on 40° C ambient conditions.

Inertia				
	Stator	1 Stack	2 Stack	3 Stack
RDM Motor Armature Inertia (+/-5%)	lb-in-sec ² (kg-cm ²)	0.000545 (0.6158)	0.000973 (1.0996)	0.001401 (1.5834)
RDG Gearmotor Armature Inertia† (+/-5%)	lb-in-sec ² (kg-cm ²)	0.000660 (0.7450)	0.001068 (1.2057)	0.001494 (1.6868)

*Add armature inertia to gearing inertia for total inertia.

L ₁₀ Radial Load and Bearing Life						
RPM	50	100	250	500	1000	3000
RDM075 lbf (N)	278 (1237)	220 (979)	162 (721)	129 (574)	102 (454)	71 (316)
RDG075 lbf (N)	343 (1526)	272 (1210)	200 (890)	159 (707)	126 (560)	88 (391)

Side load ratings shown above are for 10,000 hour bearing life at 25 mm from motor face at given rpm.

Gearmotor Mechanical Ratings					
Model	Ratio	Maximum Allowable Output Torque-Set by User lbf-in (Nm)	Output Torque at Motor Speed for 10,000 Hour Life		
			1000 RPM lbf-in (Nm)	2500 RPM lbf-in (Nm)	4000 RPM lbf-in (Nm)
RDG075-004	4:1	1618 (182.8)	384 (43.4)	292 (32.9)	254 (28.7)
RDG075-005	5:1	1446 (163.4)	395 (44.6)	300 (33.9)	260 (29.4)
RDG075-010	10:1	700 (79.1)	449 (50.7)	341 (38.5)	296 (33.4)

Two torque ratings for the RDG gearmotors are given in the table above. The left hand columns give the maximum (peak) allowable output torque for the indicated ratios of each size RDG gearmotor. This is not the rated output torque of the motor multiplied by the ratio of the reducer.

It is possible to select a configuration of the motor selection and gear ratio such that the rated motor torque, multiplied by the gear ratio exceeds these ratings. It is the responsibility of the user to ensure that the settings of the system do not allow these values to be exceeded.

The right hand columns give the output torque at the indicated speed which will result in 10,000 hour life (L10). The setup of the system will determine the actual output torque and speed.

Gearing Reflected Inertia		
Single Reduction (+/-5%)		
Gear Stages	lbf-in-sec ²	(kg-cm ²)
4:1	0.000095	(0.107)
5:1	0.000062	(0.069)
10:1	0.000117	(0.019)

Backlash and Efficiency	
	Single Reduction
Backlash at 1% Rated Torque	10 Arc min
Efficiency	91%

Motor and Gearmotor Weights			
		RDM075 without Gears	RDG075 with 1 Stage Gearing
1 Stack Stator	lb (kg)	7.4 (3.4)	9.8 (4.4)
2 Stack Stator	lb (kg)	9.2 (4.2)	11.6 (5.3)
3 Stack Stator	lb (kg)	11 (4.9)	13.4 (6.1)
		Added Weight for Brake	
		1.0 (0.5)	

RDM/G090

Rotary Motor Torque and Speed Ratings				
	Stator	1 Stack	2 Stack	3 Stack
	RPM at 48 VDC	3300	1800	1400
Continuous Torque	lbf-in (Nm)	17 (1.92)	28 (3.16)	41 (4.63)
Peak Torque	lbf-in (Nm)	21.8 (2.46)	36 (4.07)	52.8 (5.97)
Drive Current @ Continuous Torque	Amps	22	22	22
Operating Temperature Range**	-20 to 65° C (-40° C available, consult Exlar)			
Maximum Continuous Power Supply Current†	Amps	18	18	18

*Power supply current is based on software current limit, not thermal limit. Consideration for peak current should also be considered when sizing power supplies. For output torque of RDG gearmotors, multiply by ratio and efficiency. Please note maximum allowable output torques shown below.

**Ratings based on 40° C ambient conditions.

Inertia				
	Stator	1 Stack	2 Stack	3 Stack
RDM Motor Armature Inertia (+/-5%)	lb-in-sec ² (kg-cm ²)	0.00054 (0.609)	0.00097 (1.09)	0.00140 (1.58)
RDG Gearmotor Armature Inertia* (+/-5%)	lb-in-sec ² (kg-cm ²)	0.00114 (1.29)	0.00157 (1.77)	0.00200 (2.26)

*Add armature inertia to gearing inertia for total inertia.

L ₁₀ Radial Load and Bearing Life						
RPM	50	100	250	500	1000	3000
RDM090 lbf (N)	427 (1899)	340 (1512)	250 (1112)	198 (881)	158 (703)	109 (485)
RDG090 lbf (N)	350 (1557)	278 (1237)	205 (912)	163 (725)	129 (574)	89 (396)

Side load ratings shown above are for 10,000 hour bearing life at 25 mm from motor face at given rpm.

Gearmotor Mechanical Ratings					
Model	Ratio	Maximum Allowable Output Torque-Set by User lbf-in (Nm)	Output Torque at Motor Speed for 10,000 Hour Life		
			1000 RPM lbf-in (Nm)	2500 RPM lbf-in (Nm)	3300 RPM lbf-in (Nm)
RDG090-004	4:1	2078 (234.8)	698 (78.9)	530 (59.9)	488 (55.1)
RDG090-005	5:1	1798 (203.1)	896 (101.2)	680 (76.8)	626 (70.7)
RDG090-010	10:1	1126 (127.2)	1043 (117.8)	792 (89.5)	729 (82.4)
RDG090-016	16:1	2078 (234.8)	1057 (119.4)	803 (90.7)	739 (83.5)
RDG090-020	20:1	2078 (234.8)	1131 (127.8)	859 (97.1)	790 (89.3)
RDG090-025	25:1	1798 (203.1)	1452 (164.1)	1103 (124.6)	1015 (114.7)
RDG090-040	40:1	2078 (234.8)	1392 (157.3)	1057 (119.4)	973 (109.9)
RDG090-050	50:1	1798 (203.1)	1787 (201.9)	1358 (153.4)	1249 (141.1)
RDG090-100	100:1	1126 (127.2)	1100 (124.3)	1100 (124.3)	1100 (124.3)

Two torque ratings for the RDG gearmotors are given in the table above. The left hand columns give the maximum (peak) allowable output torque for the indicated ratios of each size RDG gearmotor. This is not the rated output torque of the motor multiplied by the ratio of the reducer.

It is possible to select a configuration of the motor selection and gear ratio such that the rated motor torque, multiplied by the gear ratio exceeds these ratings. It is the responsibility of the user to ensure that the settings of the system do not allow these values to be exceeded.

The right hand columns give the output torque at the indicated speed which will result in 10,000 hour life (L10). The setup of the system will determine the actual output torque and speed.

Gearing Reflected Inertia					
Gear Stages	Single Reduction		Double Reduction		
	lbf-in-sec ²	(kg-cm ²)	Gear Stages	lbf-in-sec ²	(kg-cm ²)
4:1	0.0000154	(0.174)	16:1	0.000115	(0.130)
5:1	0.0000100	(0.113)	20:1, 25:1	0.0000756	(0.0854)
10:1	0.0000265	(0.0300)	40:1, 50:1, 100:1	0.0000203	(0.0230)

Backlash and Efficiency		
	Single Reduction	Double Reduction
Backlash at 1% Rated Torque	10 Arc min	13 Arc min
Efficiency	91%	86%

Motor and Gearmotor Weights				
	RDM090 without Gears	RDG090 with 1 Stage Gearing	RDG090 with 2 Stage Gearing	Added Weight for Brake
1 Stack Stator lb (kg)	12.5 (5.7)	20.5 (9.3)	23.5 (10.7)	1.5 (0.7)
2 Stack Stator lb (kg)	15.5 (7.0)	23.5 (10.7)	26.5 (12)	
3 Stack Stator lb (kg)	18.5 (8.4)	26.5 (12.0)	29.5 (13.4)	

Speed vs. Torque Curves

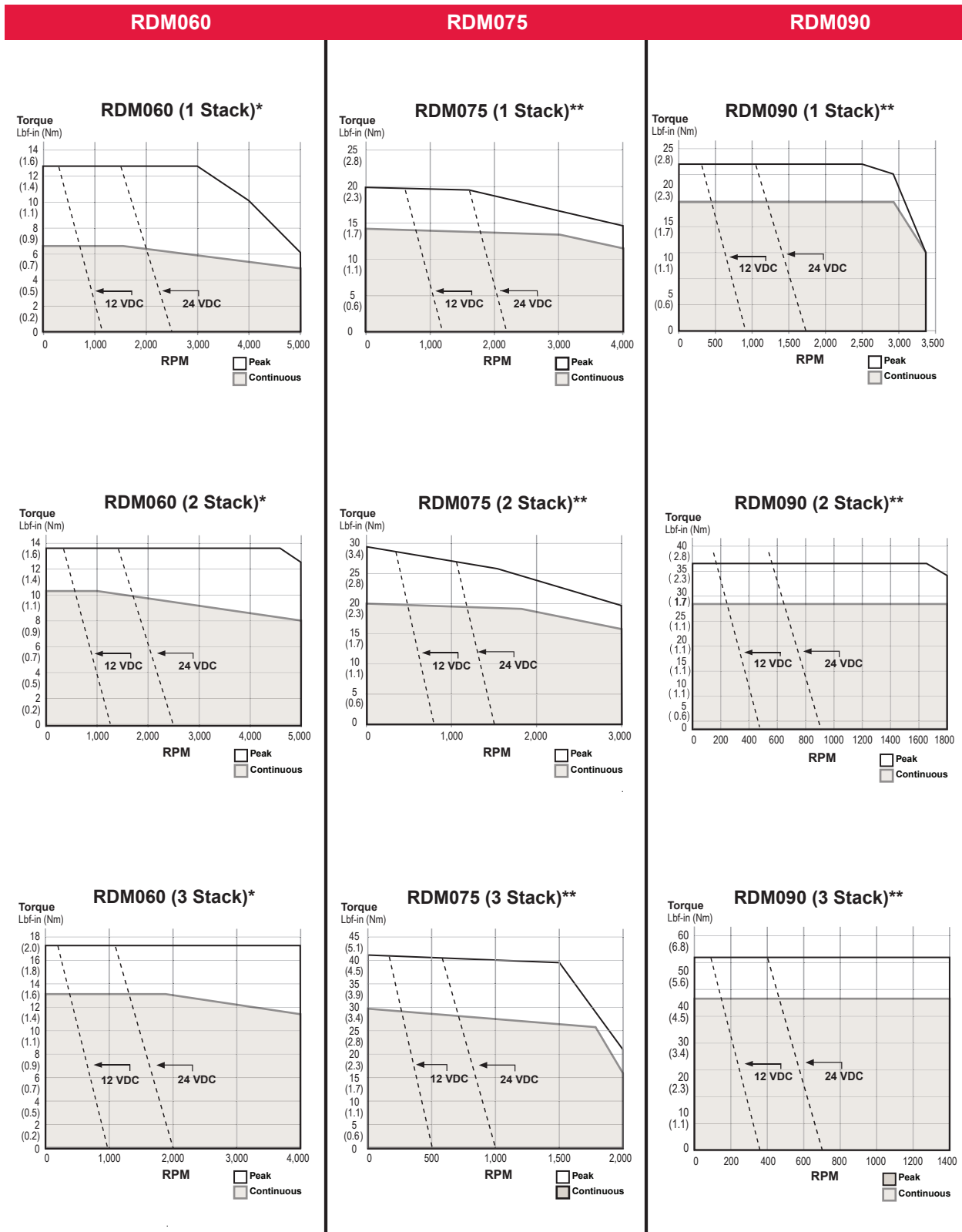

For RDG gearmotors, multiply torque by ratio and efficiency. Divide speed by gear ratio.

* RDM060 test data derived using NEMA recommended aluminum heatsink 10" x 10" x 1/4" at 40°C ambient

**RDM075 and RDM090 test data derived using NEMA recommended aluminum heatsink 10" x 10" x 3/8" at 40°C ambient

Dimensions

RDM/G060 Base Actuator

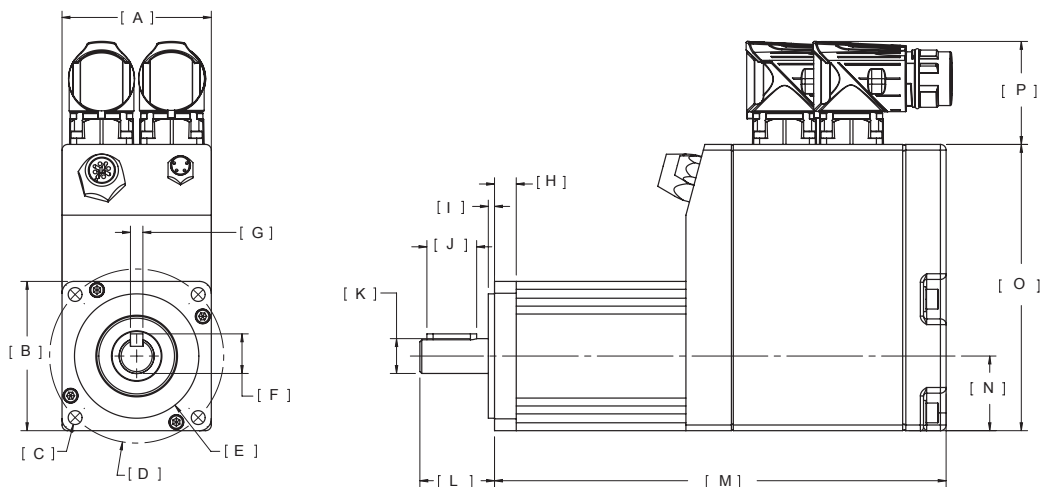

		RDM060	RDG060			RDM060	RDG060
A	in	2.36	2.36	I	in	0.10	0.12
	mm	60	60		mm	2.5	3.0
B	in	2.36	2.36	J	in	0.79	0.98
	mm	60	60		mm	20.0	25.0
C	in	4X Ø 0.22	4X Ø 0.22	K	in	Ø 0.5512 / 0.5507	Ø 0.6302 / 0.6298
	mm	5.6	5.6		mm	14 h6	16 j6
D	in	Ø 2.75 BC	Ø 2.75 BC	L	in	1.18	1.43
	mm	70.0	70.0		mm	30.0	36.3
E	in	Ø 1.9681 / 1.9675	Ø 1.9681 / 1.9675	M	in	See Below	See Below
	mm	50 g6	50 g6		mm	See Below	See Below
F	in	0.63	0.70	N	in	1.18	1.18
	mm	15.9	17.9		mm	30.0	30.0
G	in	Ø 0.1969 / 0.1957	Ø 0.1969 / 0.1957	O	in	4.53	4.53
	mm	5 h9	5 h9		mm	115.1	115.1
H	in	0.34	0.38	P	in	1.63	1.63
	mm	8.7	9.7		mm	41.4	41.4

RDM060

Without Brake Option			
DIM	1 Stack Stator	2 Stack Stator	3 Stack Stator
M	7.146 (185.1)	8.396 (213.3)	9.646 (245.0)

With Brake Option			
DIM	1 Stack Stator	2 Stack Stator	3 Stack Stator
M	7.856 (199.5)	9.106 (231.3)	10.356 (263.0)

RDG060

Without Brake Option			
DIM	1 Stack Stator 1 Stage Gearhead	2 Stack Stator 1 Stage Gearhead	3 Stack Stator 1 Stage Gearhead
M	9.434 (240)	10.684 (271)	11.934 (303)
DIM	1 Stack Stator 2 Stage Gearhead	2 Stack Stator 2 Stage Gearhead	3 Stack Stator 2 Stage Gearhead
M	10.479 (266)	11.729 (298)	12.979 (330)

With Brake Option			
DIM	1 Stack Stator 1 Stage Gearhead	2 Stack Stator 1 Stage Gearhead	3 Stack Stator 1 Stage Gearhead
M	10.144 (258)	11.394 (289)	12.644 (321)
DIM	1 Stack Stator 2 Stage Gearhead	2 Stack Stator 2 Stage Gearhead	3 Stack Stator 2 Stage Gearhead
M	11.189 (284)	12.439 (316)	13.689 (348)

Pre-sale drawings and models are representative and are subject to change. Certified drawings and models are available for a fee. Consult your local Exlar representative for details.

RDM/G075 Base Actuator

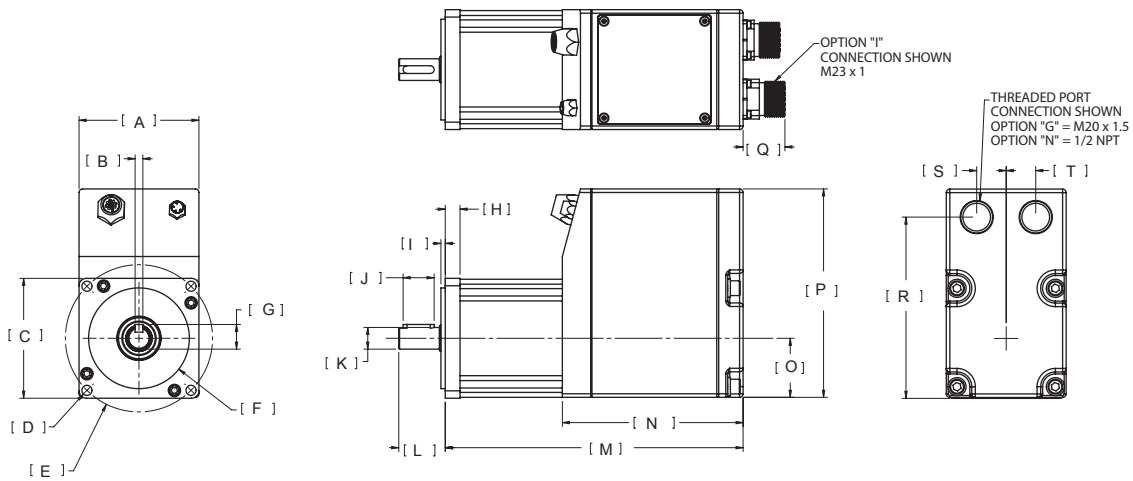

		RDM075	RDG075			RDM075	RDG075
A	in	3.05	3.05	K	in	Ø 0.5512 / 0.5508	Ø 0.6302 / 0.6298
	mm	77.4	77.4		mm	14 h6	16 j6
B	in	Ø 0.1969 / 0.1957	Ø 0.1969 / 0.1957	L	in	1.18	1.18
	mm	5 h9	5 h9		mm	30.0	30.0
C	in	□ 3.05	□ 3.05	M	in	See Below	See Below
	mm	77.4	77.4		mm	See Below	See Below
D	in	4X Ø 0.26 ON BC	4X Ø 0.26 ON BC	N	in	4.59	4.59
	mm	6.5	6.5		mm	116.6	116.6
E	in	Ø 3.74 BC	Ø 3.74 BC	O	in	1.5	1.5
	mm	95.0	95.0		mm	38.1	38.1
F	in	Ø 2.5587 / 2.5580	Ø 2.5587 / 2.5580	P	in	5.30	5.30
	mm	65 g6	65 g6		mm	134.5	134.5
G	in	0.63	0.70	Q	in	1.06	1.06
	mm	15.9	17.9		mm	27.0	27.0
H	in	0.38	0.45	R	in	4.61	4.61
	mm	9.5	11.5		mm	117.0	117.0
I	in	0.11	0.11	S	in	0.75	0.75
	mm	2.8	2.8		mm	19.1	19.1
J	in	0.79	0.79	T	in	0.75	0.75
	mm	20.0	20.0		mm	19.1	19.1

RDM075

Without Brake Option			
DIM	1 Stack Stator	2 Stack Stator	3 Stack Stator
M	7.57 (192.3)	8.57 (217.7)	9.57 (243.1)

With Brake Option			
DIM	1 Stack Stator	2 Stack Stator	3 Stack Stator
M	8.85 (224.8)	9.85 (250.2)	10.85 (275.6)

RDG075

Without Brake Option			
DIM	1 Stack Stator 1 Stage Gearhead	2 Stack Stator 1 Stage Gearhead	3 Stack Stator 1 Stage Gearhead
M	9.19 (233.4)	10.19 (258.8)	11.19 (284.2)

With Brake Option			
DIM	1 Stack Stator 1 Stage Gearhead	2 Stack Stator 1 Stage Gearhead	3 Stack Stator 1 Stage Gearhead
M	10.42 (264.7)	11.42 (290.1)	12.42 (315.5)

Pre-sale drawings and models are representative and are subject to change. Certified drawings and models are available for a fee. Consult your local Exlar representative for details.

RDM/G090 Base Actuator

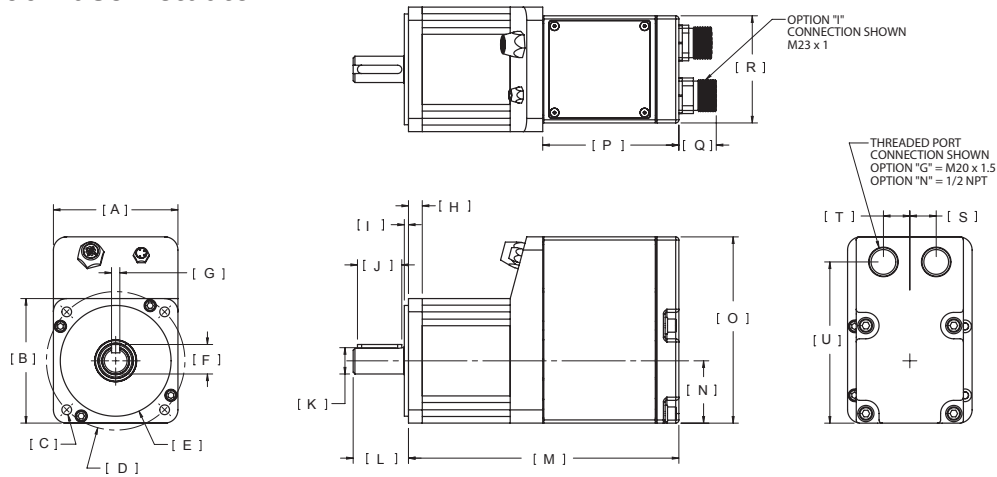

		RDM90	RDG090			RDM090	RDG090
A	in	3.54	3.54	L	in	1.57	1.89
	mm	90	90		mm	39.6	48.0
B	in	3.54	3.54	M	in	See Below	See Below
	mm	90	90		mm	See Below	See Below
C	in	4X Ø 0.28	4X Ø 0.26	N	in	1.77	1.77
	mm	7.0	6.5		mm	45.0	45.0
D	in	Ø 3.94 BC	Ø 3.94 BC	O	in	5.30	5.30
	mm	100.0	100.0		mm	134.5	134.5
E	in	Ø 3.1492 / 3.1485	Ø 3.1492 / 3.1485	P	in	3.87	3.87
	mm	80 g6	80 g6		mm	98.3	98.3
F	in	0.85	0.96	Q	in	1.06	1.06
	mm	21.5	24.3		mm	27.0	27.0
G	in	Ø 0.2362 / 0.2350	Ø 0.2362 / 0.2350	R	in	3.05	3.05
	mm	6 h9	6 h9		mm	77.4	77.4
H	in	0.39	0.63	S	in	0.75	0.75
	mm	10.0	15.9		mm	19.1	19.1
I	in	0.12	0.12	T	in	0.75	0.75
	mm	3.0	3.0		mm	19.1	19.1
J	in	1.26	1.42	U	in	4.58	4.58
	mm	32.0	36.0		mm	116.4	116.4
K	in	Ø 0.7480 / 0.7475	Ø 0.8665 / 0.8659				
	mm	19 h6	22 j6				

RDM090

Without Brake Option			
DIM	1 Stack Stator	2 Stack Stator	3 Stack Stator
M	7.69 (195.3)	8.69 (220.7)	9.69 (246.1)

With Brake Option			
DIM	1 Stack Stator	2 Stack Stator	3 Stack Stator
M	9.0 (228.6)	10.00 (254.0)	11.00 (279.4)

RDG090

Without Brake Option			
DIM	1 Stack Stator 1 Stage Gearhead	2 Stack Stator 1 Stage Gearhead	3 Stack Stator 1 Stage Gearhead
M	10.80 (274.3)	11.80 (299.7)	12.80 (325.1)
DIM	1 Stack Stator 2 Stage Gearhead	2 Stack Stator 2 Stage Gearhead	3 Stack Stator 2 Stage Gearhead
M	12.06 (306.3)	13.06 (331.7)	14.06 (357.1)

With Brake Option			
DIM	1 Stack Stator 1 Stage Gearhead	2 Stack Stator 1 Stage Gearhead	3 Stack Stator 1 Stage Gearhead
M	12.13 (308.1)	13.11 (333.0)	14.11 (358.4)
DIM	1 Stack Stator 2 Stage Gearhead	2 Stack Stator 2 Stage Gearhead	3 Stack Stator 2 Stage Gearhead
M	13.37 (339.6)	14.37 (365.0)	15.37 (390.4)

Pre-sale drawings and models are representative and are subject to change. Certified drawings and models are available for a fee. Consult your local Exlar representative for details.

Tritex II DC Linear Ordering Guide

[Return to Table of Contents](#)

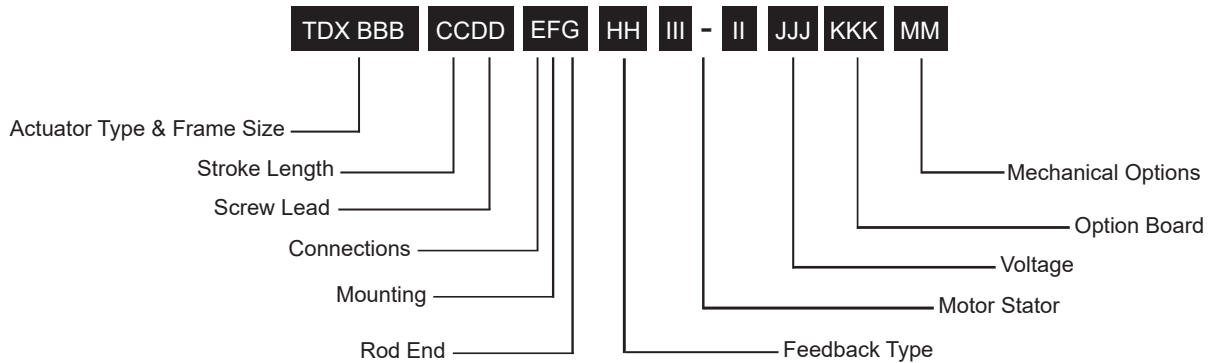

Actuator Type

TDX = Tritex II Linear Actuator, high mechanical capacity

BBB = Actuator Frame Size

060 = 60 mm
075 = 75 mm

CC = Stroke Length

03 = 3 inch (76 mm)
06 = 6 inch (152 mm)
10 = 10 inch (254 mm)
12 = 12 inch (305 mm)
18 = 18 inch (457 mm) (75 mm only)

DD = Screw Lead (linear travel per screw revolution)

01 = 0.1 inch (2.54 mm)
02 = 0.2 inch (5.08 mm)
04 = 0.4 inch (10.16 mm) (60 mm only)
05 = 0.5 inch (12.7 mm) (75 mm only)

E = Connections

G = Standard Straight Threaded Port with internal terminals, M20x1.5 (75 mm only)
N = NPT Threaded Port via Adapter with Internal Terminals, 1/2" NPT (75 mm only)
I = Intercontec Style - Exlar standard, M23 Style Connector

F = Mounting

C = Rear Clevis
G = Metric Rear Clevis
D = Double Side Mount
K = Metric Double Side Mount
E = Extended Tie Rod
M = Metric Extended Tie Rod
F = Front Flange
R = Rear Flange
T = Side Trunnion
Q = Metric Side Trunnion

G = Rod End

M = Male US Standard Thread ¹
A = Male Metric Thread ¹
F = Female US Standard Thread ¹
B = Female Metric Thread ¹

HH = Feedback Type

HD = Analog Hall Device
IE = Incremental Encoder, 8192 count resolution
AF = Absolute Feedback ⁹

III-II = Motor Stator, All 8 Pole

TDX060 Stator Specifications
1B8-50 = 1 Stack, 48 VDC, 5000 rpm
2B8-50 = 2 Stack, 48 VDC, 5000 rpm
3B8-40 = 3 Stack, 48 VDC, 4000 rpm ²

TDX075 Stator Specifications

1B8-30 = 1 Stack, 48 VDC, 3000 rpm
2B8-30 = 2 Stack, 48 VDC, 3000 rpm
3B8-20 = 3 Stack, 48 VDC, 2000 rpm ²

JJJ = Voltage

048 = 12-48 VDC

KKK = Option Board

SIO = Standard IO Interconnect
IA4 = 4-20 mA Analog I/O
EIP = SIO plus Ethernet/IP with M12 connector
EIN = SIO plus Ethernet/IP without M12 connector ⁷
PIO = SIO plus Profinet IO with M12 connector ⁷
PIN = SIO plus Profinet IO without M12 connector ⁷
TCP = SIO plus Modbus TCP with M12 connector
TCN = SIO plus Modbus TCP without M12 connector ⁹

MM = Mechanical Options ³

AR = External Anti-rotate
L1/2/3 = External Limit Switches ⁴
RB = Rear Brake
PB = Protective Bellows ⁶
SR = Splined Main Rod ^{5,8}



For options or specials not listed above or for extended temperature operation, please contact Exlar

NOTES:

1. Chrome-plated carbon steel. Threads not chrome-plated.
2. Not available on 0.1 inch lead.
3. For extended temperature operation consult factory for model number.
4. Limit switch option requires AR option.
5. This option is not sealed and is not suitable for any environment in which contaminants come in contact with actuator and may enter the actuator.
6. Not available with extended tie rod mounting option.
7. Requires customer supplied Ethernet cable through I/O port for Class 1 Division 2 compliance only.
8. Consult Exlar if ordering splined stainless steel main rod.
9. When ordering a TDM, RDM or RDG 60 mm or other sizes with top mounted connectors the battery backup for AF feedback must be mounted externally. A DIN rail mounted board (Exlar PN 48224) and battery (PN T2BAT2) are supplied.

Tritex II DC Rotary Ordering Guide

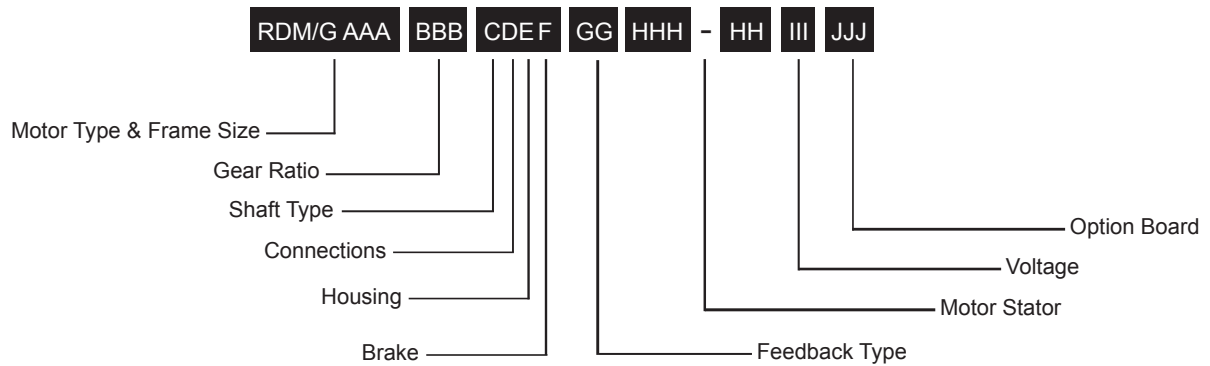

RDM/G = Motor Type

RDM = Tritex II DC Rotary Motor
RDG = Tritex II DC Rotary Gearmotor

AAA = Frame Size

060 = 60 mm
075 = 75 mm
090 = 90 mm

BBB = Gear Ratio

Blank = RDM
Single Reduction Ratios
004 = 4:1 005 = 5:1 010 = 10:1
Double Reduction Ratios (NA on 75 mm)
016 = 16:1 020 = 20:1
025 = 25:1 040 = 40:1
050 = 50:1 100 = 100:1

C = Shaft Type

K = Keyed

D = Connections

G = Standard straight threaded port with internal terminals, M20x1.5 (75 & 90 mm only)
N = NPT threaded port internal terminals, 1/2" NPT (75 & 90 mm only)
I = Intercontec style – Exlar standard, M23 Style Connector

E = Housing Options

G = Exlar Standard

F = Brake Options

S = No Brake, Standard
B = Electric Brake, 24 VDC

GG = Feedback Type

HD = Analog Hall Device
IE = Incremental Encoder, 8192 Count Resolution
AF = Absolute Feedback³

HHH-HH = Motor Stators - All 8 Pole

RDM/G060 Stator Specifications
1B8-50 = 1 Stack, 48 VDC, 5000 rpm
2B8-50 = 2 Stack, 48 VDC, 5000 rpm
3B8-40 = 3 Stack, 48 VDC, 4000 rpm

RDM/G075 Stator Specifications

1B8-40 = 1 Stack, 48 VDC, 4000 rpm
2B8-30 = 2 Stack, 48 VDC, 3000 rpm
3B8-20 = 3 Stack, 48 VDC, 2000 rpm

RDM/G090 Stator Specifications

1B8-33 = 1 Stack, 48 VDC, 3300 rpm
2B8-18 = 2 Stack, 48 VDC, 1800 rpm
3B8-14 = 3 Stack, 48 VDC, 1400 rpm

III = Voltage

048 = 12-48 VDC

JJJ = Option Board

SIO = Standard I/O Interconnect
IA4 = + 4-20 mA Analog I/O
EIP = SIO plus EtherNet/IP with M12 connector
EIN = SIO plus EtherNet/IP without M12 connector²
PIO = SIO plus Profinet IO w/M12 connector
PIN = SIO plus Profinet IO without M12 connector²
TCP = SIO plus Modbus TCP w/M12 connector
TCN = SIO plus Modbus TCP without M12 connector²



For options or specials not listed above or for extended temperature operation, please contact Exlar

NOTES:

1. For extended temperature operation consult factory for model number.
2. Requires customer supplied Ethernet cable through I/O port for Class 1 Division 2 compliance only. Also N/A on 60 mm.
3. When ordering a TDM, RDM or RDG 60 mm or other sizes with top mounted connectors the battery backup for AF feedback must be mounted externally. A DIN rail mounted board (Exlar PN 48224) and battery (PN T2BAT2) are supplied.

Cables and Accessories

Tritex II DC Series Cable & Accessories	Part No.
Communications Accessories - Tritex uses a 4 pin M8 RS485 communications connector	
Recommended PC to Tritex communications cable-USB/RS485 to M8 connector - xxx = Length in feet, 006 or 015 only	CBL-T2USB485-M8-xxx
Multi-Drop RS485 Accessories	
RS485 splitter - M8 Pin plug to double M8 Socket receptacle	TT485SP
Multidrop Communications Cable M8 to M8 for use with TT485SP/RS485 splitter - xxx = Length in feet, 006 or 015 only	CBL-TTDAS-xxx
“G” Connection Accessories (N/A for 60 mm)	
Nickel plated cable gland- M20 x 1.5 - CE shielding- 2 required	GLD-T2M20 x 1.5
Power cable prepared on one end for use with GLD-T2M20 x 1.5 xxx = Length in ft, Standard lengths 015, 025, 050, 075, 100	CBL-TDIPC-RAW-xxx
I/O cable prepared on one end for use with GLD-T2M20 x 1.5 xxx = Length in ft, Standard lengths 015, 025, 050, 075, 100	CBL-T2IOC-RAW-xxx
“N” Connection Accessories (N/A for 60 mm)	
M20 x 1.5 to 1/2" NPT threaded hole adapter for use with conduit	ADAPT-M20-NPT1/2
“I” Connection	
Power cable with M23 8 pin xxx = Length in feet, std lengths 015, 025, 050, 075, 100	CBL-TTIPC-SMI-xxx
I/O cable with M23 19 pin xxx = Length in feet, std lengths 015, 025, 050, 075, 100	CBL-TTIOC-SMI-xxx
Multi-Purpose Communications Accessories for long runs, requires terminal block interconnections	
USB to RS485 convertor/cable - USB to RS485 flying leads - xxx = Length in feet, 006 or 015 only	CBL-T2USB485-xxx
Communications cable M8 to flying leads cable xxx = Length in feet, standard lengths 015, 025, 050, 075, 100	CBL-TTCOM-xxx
Option Board Cables and Accessories	
EIP, PIO and TCP option Ethernet cable - M12 to RJ45 cable xxx = Length in feet, standard lengths 015, 025, 050, 075, 100.	CBL-T2ETH-R45-xxx
Electrical Accessories	
Shunt resistor used for Dynamic Braking	TTSR1
Replacement -AF Battery - 75 mm frame only used for absolute feedback option	54108
Replacement -External Battery, Absolute Feedback option only (60mm frame)	T2BAT2
Replacement -AF Battery Board, T2BAT2 not included, DIN Rail mounted, Absolute Feedback option only (60mm frame)	48224
Surge Filter DIN rail mounted	TDCEFS1
Replacement Normally Closed External Limit Switch (Turck Part No. BIM-UNT-RP6X)	43404
Replacement Normally Open External Limit Switch (Turck Part No. BIM-UNT-AP6X)	43403
Mechanical Accessories	
Clevis Pin for TDX060 Rod Clevis & Rear Clevis	CP050*
Clevis Pin for TDX075 Rear Clevis	CP075
Spherical Rod Eye for TDX060 male “M” rod end 3/8-24 thread	SRM038
Spherical Rod Eye for TDX075 male “M” rod end 7/16-20 thread	SRM044
Rod Eye for TDX075 male “M” rod end 7/16-20 thread	RE050
Rod Clevis for TDX060 male “M” rod end 3/8-24 thread	RC038
Rod Clevis for TDX075 male “M” rod end 7/16-20 thread	RC050
Jam Nut for TDX060 male rod end, 3/8-24	JAM3/8-24-SS
Jam Nut for TDX075 male rod end, 7/16-20	JAM7/16-20-SS

*Also available for TDX075 with RC050, RE050



CBL-T2USB485-M8-xxx
Our recommended communications cable. No special drivers or setup required for use with MS Windows™.



CBL-T2USB485-xxx
Use for terminal connections with CBL-TTCOM for long cable runs. No special drivers or setup required for use with MS Windows™.



CBL-TTIOC-SMI-xxx



CBL-TTIPC-SMI-xxx



CBL-TTCOM-xxx
Use with CBL-T2USB485-xxx for long cable runs.



CBL-TTDAS-xxx
For use with TT485SP for multi-drop applications.

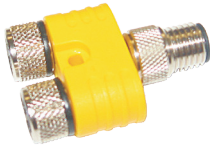

TT485SP
RS485 communications splitter. Use to daisy-chain multiple Tritex actuators.

TDCESF1
Surge filter designed for use on Tritex 48 VDC rotary and linear actuators provides EFT/B and surge disturbance immunity to IEC/EN 61800-3:2004-08 Second Environment (industrial) levels. Electrical Fast Transient/Burst (EET/B) and surge disturbances are caused by a number of events including switching inductive loads, relay contact bounce, power system switching activity or faults, nearby lightning strikes, etc.

[Return to Table of Contents](#)

FT SERIES

HIGH FORCE ROLLER SCREW ACTUATOR

Mount virtually any servo motor

Long stroke lengths available

High speed and long life

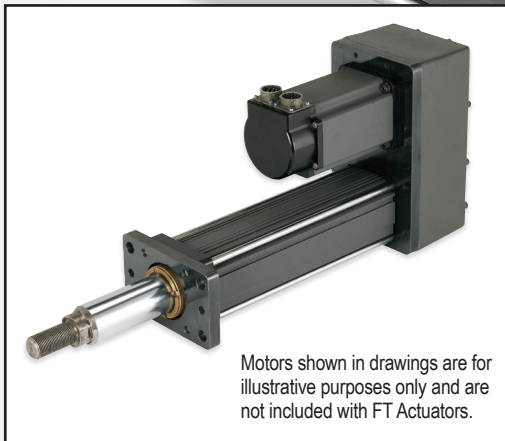
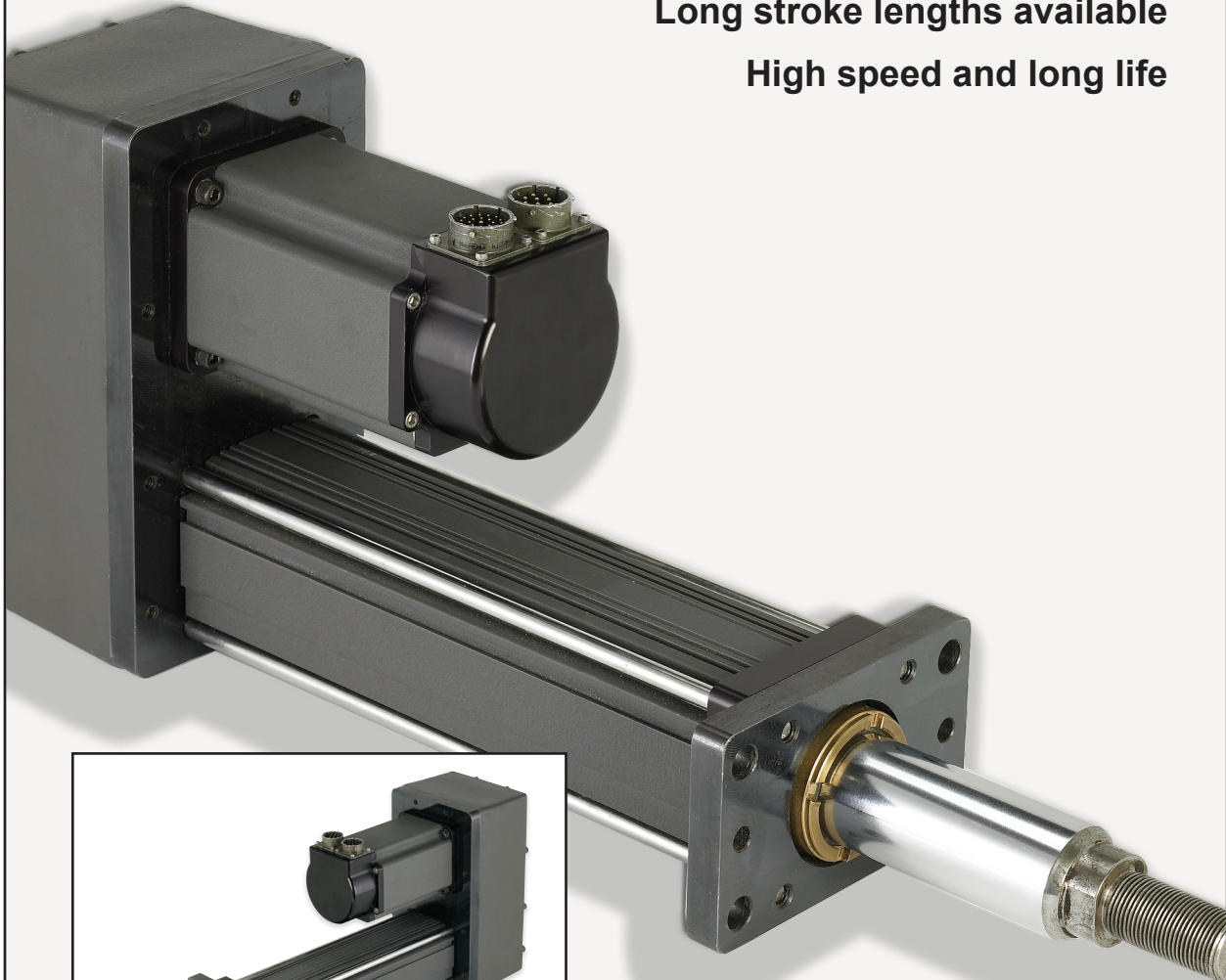

Motors shown in drawings are for illustrative purposes only and are not included with FT Actuators.

FT Series

Linear Actuators

High Performance

As with all Exlar roller screw products, the FT Series actuators deliver heavy load capacity, high speed capabilities, and exceptionally long life when compared to other linear actuator technologies.

Other comparably-sized screw actuator products on the market, specifically ball screw and acme screw actuators, have relatively low load capacities, short working lives and limited speed capabilities. At equivalent sizes, under moderate to heavy loads, it is reasonable to project that FT units will deliver up to 15 times the working life of those other methods. For OEM designers, this often means much more power and durability can be achieved from a much smaller footprint when Exlar FT units are used.

Contamination Protection

The FT Series design has all the contamination-isolation advantages of hydraulic cylinders without the limited load, life, and speed of designs built around ball or acme screws. The bearing and roller screw components in the Exlar FT Series force tubes are mounted within the sealed housing. This prevents abrasive particles and other contaminants from entering the actuator's critical mechanisms, and assures trouble-free operation even in the most severe environments.

FT Series actuators are provided with standard grease lubrication. Custom provisions can be made for oil filled lubrication.

Feature	Standard
Long Strokes	6 inch, 12 inch, 18 inch, 24 inch, 36 inch, and 48 inch
Multiple Actuator Mountings	Side Mount, Side Lug, Extended Tie Rods, Rear Clevis, Front Flange, Side Trunnion, Rear Flange, Front/Rear Flange
Multiple Motor Mounting Configurations	Inline Direct Drive, Parallel 1:1 Drive, Parallel, 2:1 Reduction

Engineered Compatibility

Exlar has removed much of the end-user-engineering burden by designing the FT series to be compatible with a wide variety of standard motors. Motor mounting, actuator mounting, and gearing configurations are available to meet nearly any application's requirements.

Exlar FT Series force tube actuators use a planetary roller screw mounted inside a tube mechanism. The follower is attached to the moveable force tube, which then extends and retracts as the screw rotates. An external motor (supplied by Exlar or the customer) provides the rotational force.

Technical Characteristics	
Frame Sizes - in (mm)	3.5 (90), 4.7 (120), 5.9 (150), 7.9 (200)
Screw Leads - in (mm)	0.2 (5), 0.25 (6), 0.4 (10), 0.5 (12), 0.8 (20), 1.2 (30)
Standard Stroke Lengths in (mm)	6 (152)*, 12 (305), 18 (457), 24 (610), 36 (914), 48 (1219)
Force Range	up to 40,000 lbf (178 kN)
Maximum Speed	up to 60 in/sec (1524 mm/s)

*Not on FT60 or FT80

Operating Conditions and Usage		
Accuracy:		
Screw Lead Error	in/ft (μm / 300 mm)	0.001 (25)
Screw Travel Variation	in/ft (μm / 300 mm)	0.0012 (30)
Screw Lead Backlash*	in (mm)	0.002 (0.06)
Friction Torque Values	lbf-in (Nm)	FT35: 7.0 (0.79) FT45: 11.00 (1.24) FT60: 14.0 (1.58) FT80: 35.0 (3.95)
Efficiency:		
Motor Inline	%	80
Motor Parallel	%	80
Ambient Conditions:		
Standard Ambient Temperature	°C	0 to 65
Extended Ambient Temperature***	°C	-30 to 65
Storage Temperature	°C	-40 to 85
IP Rating**		IP65

* System backlash will be different with various types of motor mounting arrangements and couplings. Please discuss your particular configuration with your local sales representative.

** For IP65S sealing of unit with motor mounted, please contact your local sales representative.

*** Consult Exlar for extended temperature operation.

FT Series Linear Actuators

Product Features

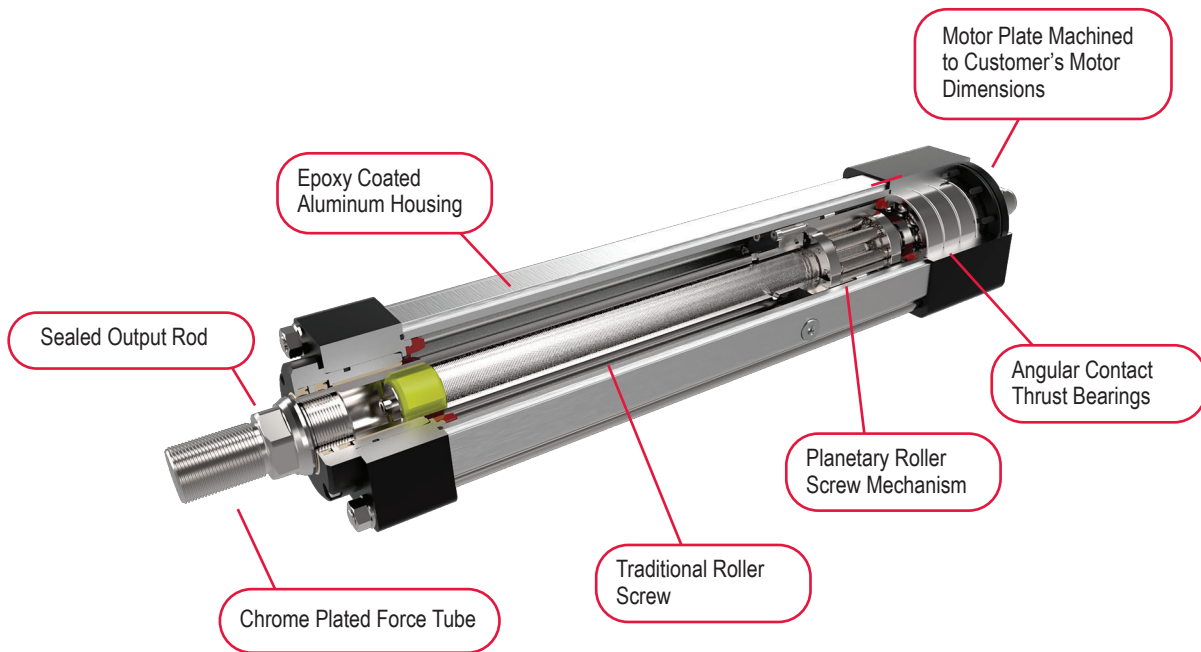

- 1 - Front flange, English
- 2 - Front flange, metric
- 3 - Rear flange, English
- 4 - Rear clevis, English
- 5 - Rear clevis, metric
- 6 - Rear eye English
- 7 - Rear eye, metric
- 8 - Side Lug Mount
- 9 - Double side mount and metric double side mount
- 10 - Side trunnion and metric side trunnion
- 11 - Rear trunnion and metric rear trunnion
- 12 - Extended tie rods and metric extended tie rods
- 13 - In-line direct drive
- 14 - Parallel, 1:1 belt reduction
Parallel, 2:1 belt reduction
- 15 - Male, US standard thread
- 16 - Male, metric thread
- 17 - Female, US standard thread
- 18 - Female, metric thread
- 19 - External limit switch - N.O., PNP or NPN
- 20 - External limit switch - N.C., PNP or NPN

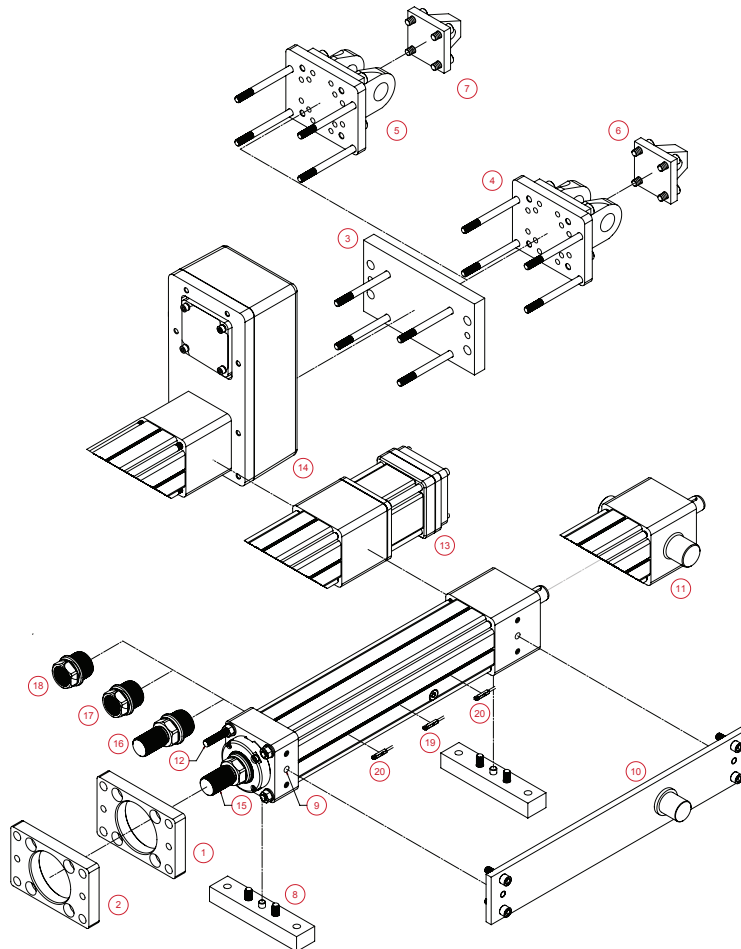

Industries and Applications

Hydraulic cylinder replacement
 Ball screw replacement
 Pneumatic cylinder replacement

Automotive

Lift station
 Automated assembly
 Riveting / fastening / joining
 Pressing

Sawmill/Forestry

Saw positioning
 Fence positioning

Process Control

Conveyor diverters / gates
 Precision valve control
 Tension control

Machining

Automated flexible fixturing
 Machine tool
 Parts clamping
 Precision grinders

Entertainment / Simulation

Action simulators
 Ride automation

Material Handling

Stamping
 Indexing stages
 Product sorting
 Material cutting
 Web guidance
 Wire winding
 Pressing
 Tube bending

Test

Test stands

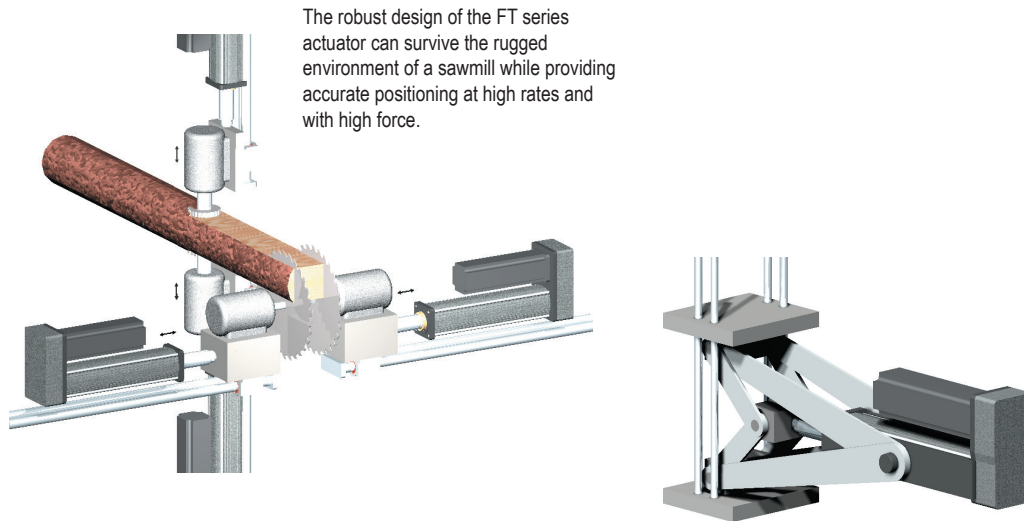

The robust design of the FT series actuator can survive the rugged environment of a sawmill while providing accurate positioning at high rates and with high force.

With their high thrust capability, compact size and smooth controlled motion, FT Series actuators are an ideal replacement for hydraulics or pneumatics on injection mold toggles. Control improvements from an electromechanical servo system offer less abuse of valuable molds and more consistent performance.

Motors shown in drawings are for illustrative purposes only and are not included with FT Actuators.

Mechanical Specifications

FT35

		High Capacity			Standard Capacity		
		05	10	20	05	10	20
Screw Lead	in	0.197	0.394	0.787	0.197	0.394	0.787
	mm	5	10	20	5	10	20
Maximum Force ²	lbf	5,000	5,000	5,000	5,000	5,000	5,000
	kN	22.2	22.2	22.2	22.2	22.2	22.2
Estimated L ₁₀ Life at Maximum Force	in x 10 ⁶	15.4	24.6	56.7	8.88	14.15	32.05
	km	392	626	1,440	225.6	359.4	814.2
C _a (Dynamic Load Rating)	lbf	21,400	19,850	20,800	17,800	16,500	17,200
	kN	95.2	88.3	92.5	79.2	73.4	76.5
Maximum Input Torque	lbf-in	196	392	783	196	392	783
	Nm	22.1	44.3	88.5	22.1	44.3	88.5
Max Rated RPM @ Input Shaft	RPM	4,500	4,500	4,500	4,500	4,500	4,500
Maximum Linear Speed @ Maximum Rated RPM	in/sec	14.7	29.5	59.3	14.7	29.5	59.3
	mm/sec	373	750	1,506	373	750	1,506

¹ FT35 actuators with high capacity screw option are 20 mm longer. See dimensions page 104.

² Maximum allowable actuator-generated force that can be applied routinely. Exceeding this force may result in permanent damage to the actuator. For high force, short stroke applications, consult factory.

Weights kg (lbs)

Base Actuator Weight	Stroke Length	6 Inch	12 Inch	18 Inch	24 Inch	36 Inch	48 Inch
	lb		30	35	40	45	55
kg		14	16	18	21	25	30

Adder for Inline (excluding motor)	Adder for Parallel Drive (excluding motor)	Adder for Front Flange	Adder for Rear Flange	Adder for Rear Clevis	Adder for Rear Eye	Adder for Front/Rear Angle Mounts	Adder for Two Trunnions	Adder for Two Foot Mounts
8 (3.6)	16 (7.3)	5.4 (2.5)	7.4 (3.4)	3.0 (1.4)	NA	NA	19.5 (8.9)	3.3 (1.5)

FT35 Reflective Inertias	5 mm Lead	10 mm Lead	20 mm Lead	
NMT Unit - J (0)	0.0004087	0.0004121	0.0004259	kg-m ² (at input shaft)
NMT Unit - J (Stroke)	0.0000159	0.0000162	0.0000171	kg-m ² /inch of stroke
Inline w/ Coupler - J (0)	0.0005127	0.0005161	0.0005299	
Inline w/ Coupler - J (Stroke)	0.0000159	0.0000162	0.0000171	
Parallel 1:1 - J (0)	0.0011042	0.0011855	0.0014480	kg-m ² (at motor shaft)
Parallel 1:1 - J (Stroke)	0.0000159	0.0000162	0.0000171	kg-m ² /inch of stroke
Parallel 2:1 - J (0)	0.0014029	0.0014038	0.0015345	
Parallel 2:1 - J (Stroke)	0.0000040	0.0000040	0.0000043	

¹ Pulleys for parallel mount match actuator max performance ratings

Standard Inline Coupling Inertia	
FT35	Inertia
	0.000104 kg-m ² (0.000920 lbf-in s ²)

Pulley inertias reflected at motor including typical pulleys, belt and standard bushings. Because of differences in belt and pulley selection due to particular motor choices, please contact your local sales representative if these values are critical to your application.

Intermediate and custom stroke lengths are available. Belt and pulley inertia varies with ratio and motor selection. Please contact your local sales representative.

*See definitions on page 100

FT45

		High Capacity		Standard Capacity	
		05	10	05	10
Screw Lead	in	0.197	0.394	0.197	0.394
	mm	5	10	5	10
Maximum Force ¹	lbf	10,000	10,000	10,000	10,000
	kN	44.5	44.5	44.5	44.5
Estimated L ₁₀ Life at Maximum Force	in x 10 ⁶	9.81	19.14	5.67	11.06
	km	249.2	486.3	144.0	280.9
C _a (Dynamic Load Rating)	lbf	36,800	36,500	30,650	30,400
	kN	163.7	162.4	136.3	135.2
Maximum Input Torque	lbf-in	392	783	392	783
	Nm	44.1	88.2	44.1	88.2
Max Rated RPM @ Input Shaft	RPM	3,500	3,500	3,500	3,500
Maximum Linear Speed @ Maximum Rated RPM	in/sec	11.5	23.0	11.5	23.0
	mm/sec	292	584	292	584

¹ Maximum allowable actuator-generated force that can be applied routinely. Exceeding this force may result in permanent damage to the actuator. For high force, short stroke applications, consult factory.

Weights kg (lbs)

Base Actuator Weight	Stroke Length	6 Inch	12 Inch	18 Inch	24 Inch	36 Inch	48 Inch
	lb	57	68	79	90	112	135
	kg	26	31	36	41	51	61

Adder for Inline (excluding motor)	Adder for Parallel Drive (excluding motor)	Adder for Front Flange	Adder for Rear Flange	Adder for Rear Clevis	Adder for Rear Eye	Adder for Front/Rear Angle Mounts	Adder for Two Trunnions	Adder for Two Foot Mounts
7.1 (3.2)	42.5 (19.3)	6.1 (2.8)	17.4 (7.9)	18.9 (8.6)	19.8 (9)	NA	17.2 (7.8)	10.4 (4.7)

FT45 Reflective Inertias	5 mm Lead	10 mm Lead	
NMT Unit - J (0)	0.002463	0.002474	kg-m ² (at input shaft)
NMT Unit - J (Stroke)	0.000045	0.000046	kg-m ² /inch of stroke
Inline w/ Coupler - J (0)	0.002571	0.002581	kg-m ² (at motor shaft) kg-m ² /inch of stroke
Inline w/ Coupler - J (Stroke)	0.000045	0.000046	
Parallel 1:1 - J (0)	0.006911	0.006921	
Parallel 1:1 - J (Stroke)	0.000045	0.000046	
Parallel 2:1 - J (0)	0.003466	0.003469	
Parallel 2:1 - J (Stroke)	0.000011	0.000011	

[†]Pulleys for parallel mount match actuator max performance ratings

Standard Inline Coupling Inertia	
FT45	Inertia
	0.00010743 kg-m ² (0.000951 lbf-in s ²)

Pulley inertias reflected at motor including typical pulleys, belt and standard bushings. Because of differences in belt and pulley selection due to particular motor choices, please contact your local sales representative if these values are critical to your application.

*See definitions on page 100

FT Series Linear Actuators

FT60

		High Capacity			Standard Capacity		
		06	12	30	06	12	30
Screw Lead	in	0.236	0.472	1.181	0.236	0.472	1.181
	mm	6	12	30	6	12	30
Maximum Force ¹	lbf	20,000	20,000	20,000	20,000	20,000	20,000
	kN	89.0	89.0	89.0	89.0	89.0	89.0
Estimated L ₁₀ Life at Maximum Force	in x 10 ⁶	5.7	7.3	38.6	4.1	5.2	10.7
	km	145.8	184.7	981.1	104.8	133.1	271.9
C _a (Dynamic Load Rating)	lbf	57,933	49,750	63,958	51,900	44,600	41,700
	kN	257.7	221.3	284.5	230.9	198.4	185.5
Maximum Input Torque	lbf-in	940	1880	4699	940	1880	4699
	Nm	106	212	531	106	212	531
Max Rated RPM @ Input Shaft	RPM	2,000	2,000	2,000	2,000	2,000	2,000
Maximum Linear Speed @ Maximum Rated RPM	in/sec	7.9	15.8	39.0	7.9	15.8	39.0
	mm/sec	201	401	991	201	401	991

¹ Maximum allowable actuator-generated force that can be applied routinely. Exceeding this force may result in permanent damage to the actuator. For high force, short stroke applications, consult factory.

Weights kg (lbs)

Base Actuator Weight	Stroke Length	12 inch	24 inch	36 inch	48 inch
	lb	100	130	160	190
	kg	45	59	72	86

Adder for Inline (excluding motor)	Adder for Parallel Drive (excluding motor)	Adder for Front Flange	Adder for Rear Flange	Adder for Rear Clevis	Adder for Rear Eye	Adder for Front/Rear Angle Mounts	Adder for Two Trunnions	Adder for Two Foot Mounts
20.4 (9.3)	39.1 (17.7)	13.4 (6.1)	15.9 (7.2)	11.1 (5)	NA	NA	44.3 (20.1)	10.4 (4.7)

FT60 Reflective Inertias	6 mm Lead	12 mm Lead	30 mm Lead	
NMT Unit - J (0)	0.0078464	0.0078709	0.0080424	kg-m ² (at input shaft)
NMT Unit - J (Stroke)	0.0002539	0.0002547	0.0002600	kg-m ² /inch of stroke
Inline w/ Coupler - J (0)	0.0081764	0.0082009	0.0083724	kg-m ² (at motor shaft)
Inline w/ Coupler - J (Stroke)	0.0002539	0.0002547	0.0002600	
Parallel 1:1 - J (0)	0.0129357	0.0146113	0.0312682	kg-m ² /inch of stroke
Parallel 1:1 - J (Stroke)	0.0002539	0.0002547	0.0002600	
Parallel 2:1 - J (0)	0.0049158	0.0057202	0.0214777	
Parallel 2:1 - J (Stroke)	0.0000635	0.0000637	0.0000650	

¹Pulleys for parallel mount match actuator max performance ratings

Standard Inline Coupling Inertia	
FT60	Inertia
	0.000330 kg-m ² (0.002921 lbf-in s ²)

Pulley inertias reflected at motor including typical pulleys, belt and standard bushings. Because of differences in belt and pulley selection due to particular motor choices, please contact your local sales representative if these values are critical to your application.

Intermediate and custom stroke lengths are available. Belt and pulley inertia varies with ratio and motor selection. Please contact your local sales representative.

*See definitions on page 100

FT80

		High Capacity			Standard Capacity		
		06	12	30	06	12	30
Screw Lead	in	0.236	0.472	1.181	0.236	0.472	1.181
	mm	6	12	30	6	12	30
Maximum Force ¹	lbf	40,000	40,000	40,000	40,000	40,000	40,000
	kN	177.9	177.9	177.9	177.9	177.9	177.9
Estimated L ₁₀ Life at Maximum Force	in x 10 ⁶	3.1	4.4	16.3	1.94	2.55	5.00
	km	78.7	111.4	414.3	49.3	64.9	127
C _a (Dynamic Load Rating)	lbf	94,330	84,079	95,971	80,700	70,200	64,700
	kN	419.6	374	426.9	359	312.2	287.8
Maximum Input Torque	lbf-in	1,880	3,760	9,399	1,880	3,760	9,399
	Nm	212	425	1,062	212	425	1,062
Max Rated RPM @ Input Shaft	RPM	1,750	1,750	1,750	1,750	1,750	1,750
Maximum Linear Speed @ Maximum Rated RPM	in/sec	6.9	13.8	34.4	6.9	13.8	34.4
	mm/sec	175	351	874	175	351	874

¹ Maximum allowable actuator-generated force that can be applied routinely. Exceeding this force may result in permanent damage to the actuator. For high force, short stroke applications, consult factory.

Weights kg (lbs)

Base Actuator Weight	Stroke Length	12 Inch	24 Inch	36 Inch	48 Inch
	lb	190	265	340	415
	kg	86	120	153	187

Adder for Inline (excluding motor)	Adder for Parallel Drive (excluding motor)	Adder for Front Flange	Adder for Rear Flange	Adder for Rear Clevis	Adder for Rear Eye	Adder for Front/Rear Angle Mounts	Adder for Two Trunnions	Adder for Two Foot Mounts
54.9 (24.9)	79.1 (35.9)	28.5 (17.5)	NA	NA	NA	NA	NA	34.8 (15.8)

FT80 Reflective Inertias	6 mm Lead	12 mm Lead	30 mm Lead	
NMT Unit - J (0)	0.0302504	0.0303275	0.0308673	kg-m ² (at input shaft)
NMT Unit - J (Stroke)	0.0008022	0.0008035	0.0008124	kg-m ² /inch of stroke
Inline w/ Coupler - J (0)	0.0314604	0.0315375	0.0320773	kg-m ² (at motor shaft)
Inline w/ Coupler - J (Stroke)	0.0008022	0.0008035	0.0008124	
Parallel 1:1 - J (0)	0.0721056	0.0535533	0.1342578	kg-m ² /inch of stroke
Parallel 1:1 - J (Stroke)	0.0008022	0.0008035	0.0008124	
Parallel 2:1 - J (0)	0.0198765	0.0270490	0.0753395	
Parallel 2:1 - J (Stroke)	0.0002006	0.0002009	0.0002031	

[†]Pulleys for parallel mount match actuator max performance ratings

Standard Inline Coupling Inertia	
FT80	Inertia
	0.0001210 kg-m ² (0.010709 lbf-in s ²)

Pulley inertias reflected at motor including typical pulleys, belt and standard bushings. Because of differences in belt and pulley selection due to particular motor choices, please contact your local sales representative if these values are critical to your application.

Intermediate and custom stroke lengths are available. Belt and pulley inertia varies with ratio and motor selection. Please contact your local sales representative.

*See definitions on page 100

FT Series Linear Actuators

DEFINITIONS:

Maximum Force: Calculated Cubic Mean Load for the application should not exceed this value. (Values are derived from the design capacity of the FT Series actuator and should not be exceeded or relied upon for continuous operation.)

Life at Maximum Force: Estimated life that can be expected from the actuator when running at Maximum Force for intermittent periods of time. (Theoretical calculation based on the Dynamic Load Rating of the actuator and using the Maximum Force rating as the Cubic Mean Load.)

C_s (Dynamic Load Rating): A design constant used when calculating the estimated travel life of the roller screw.

Maximum Input Torque: The torque required at the screw to produce the Maximum Force rating. Exceeding this value can cause permanent damage to the actuator.

Maximum Rated RPM: The maximum allowable rotational screw speed determined by either screw length limitations or the rotational speed limit of the roller screw nut.

Maximum Linear Speed: The linear speed achieved by the actuator when Maximum Rated RPM is applied to the roller screw input shaft.

FT Series Accessories

Limit Switches (if required in addition to L1, L2, L3 option in actuator model)			
FT35, FT60, FT80			
Option	Quantity	Part Number	Description
L1	1	14453	Normally Closed PNP Limit Switch (10-30 VDC, 1m. 3 wire embedded cable)
L2	2	14453	Normally Closed PNP Limit Switch (10-30 VDC, 1m. 3 wire embedded cable)
L3	3	14453	Normally Closed PNP Limit Switch (10-30 VDC, 1m. 3 wire embedded cable)
L4			NA
L5			NA
L6			NA
FT45			
L1	1	43403	Normally Open PNP Limit Switch (10-30 VDC, 1m. 3 wire embedded cable)
L2	2	43404	Normally Closed PNP Limit Switch (10-30 VDC, 1m. 3 wire embedded cable)
L3	1	43403	Normally Open PNP Limit Switch (10-30 VDC, 1m. 3 wire embedded cable)
	2	43404	Normally Closed PNP Limit Switch (10-30 VDC, 1m. 3 wire embedded cable)
L4	1	67634	Normally Open NPN Limit Switch (10-30 VDC, 1m. 3 wire embedded cable)
L5	2	67635	Normally Closed NPN Limit Switch (10-30 VDC, 1m. 3 wire embedded cable)
L6	1	67634	Normally Open NPN Limit Switch (10-30 VDC, 1m. 3 wire embedded cable)
	2	67635	Normally Closed NPN Limit Switch (10-30 VDC, 1m. 3 wire embedded cable)

Consult your local sales representative to discuss maximum stroke length allowable with your final configuration.

Estimated Service Life

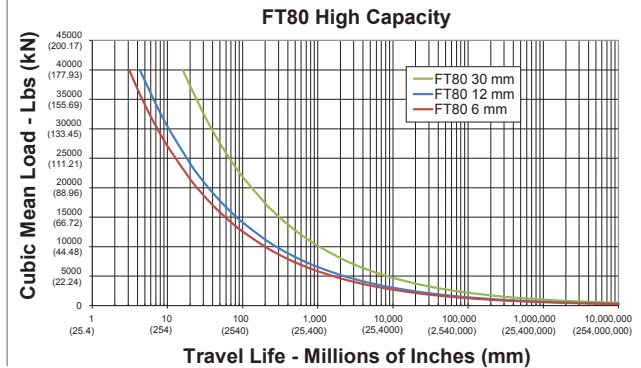
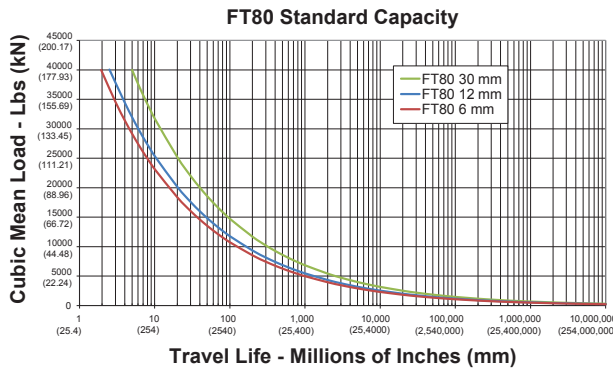
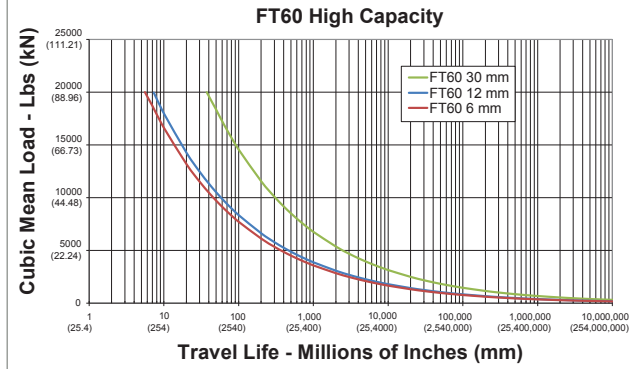
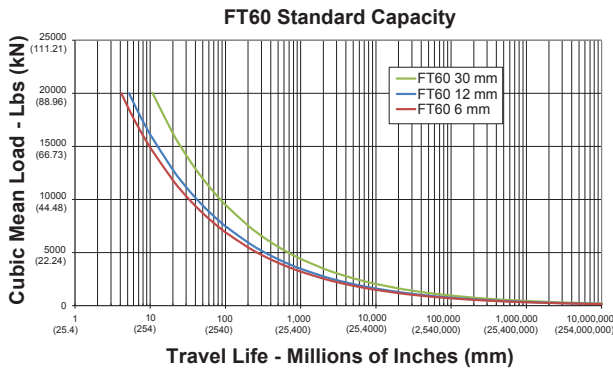
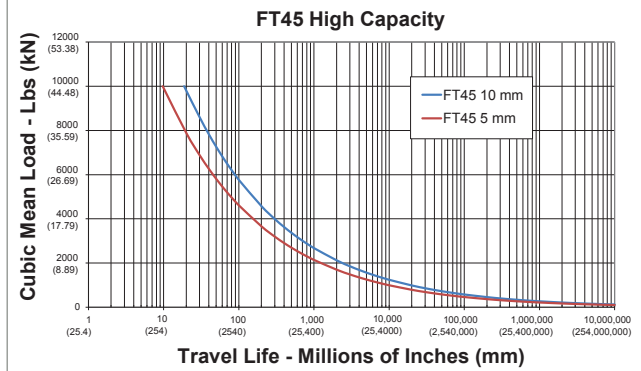
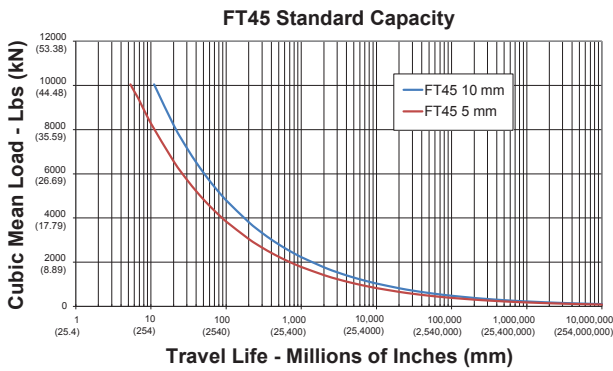
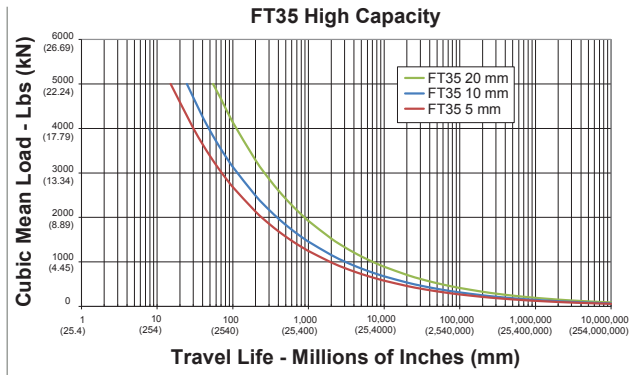
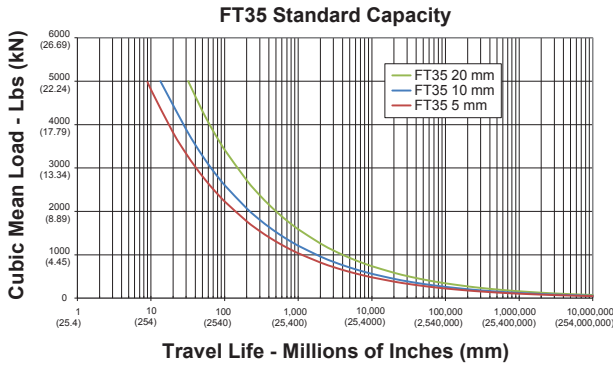

FT Series Linear Actuators

Service Life Estimate Assumptions:

- Sufficient quality and quantity of lubrication is maintained throughout service life (please refer to engineering reference on page 169 for lubrication interval estimates.)
- Bearing and screw temperature between 20° C and 40° C
- No mechanical hard stops (external or internal) or impact loads
- No external side loads
- Does not apply to short stroke, high frequency applications such as fatigue testing or short stroke, high force applications such as pressing. (For information on calculating estimating life for unique applications please refer to the engineering reference on page 169.

The L_{10} expected life of a roller screw linear actuator is expressed as the linear travel distance that 90% of properly maintained roller screws manufactured are expected to meet or exceed. This is not a guarantee and these charts should be used for estimation purposes only.

The underlying formula that defines this value is:
Travel life in millions of inches, where:

$$L_{10} = \left(\frac{C_a}{F_{cml}} \right)^3 \times \ell$$

C_a = Dynamic load rating (lbf)
 F_{cml} = Cubic mean applied load (lbf)
 ℓ = Roller screw lead (inches)

For additional details on calculating estimated service life, please refer to the Engineering Reference, page 169.

Data Curves

Critical Speed vs Stroke Length:

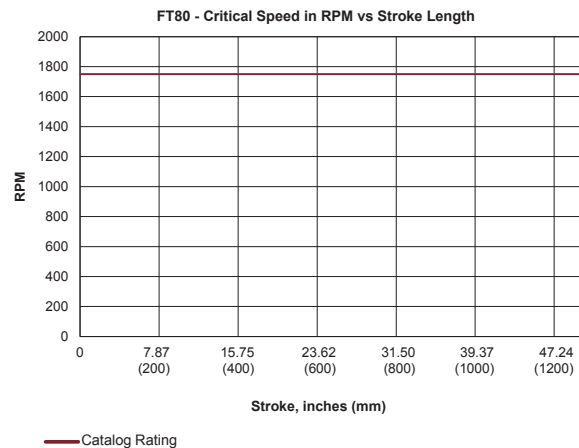
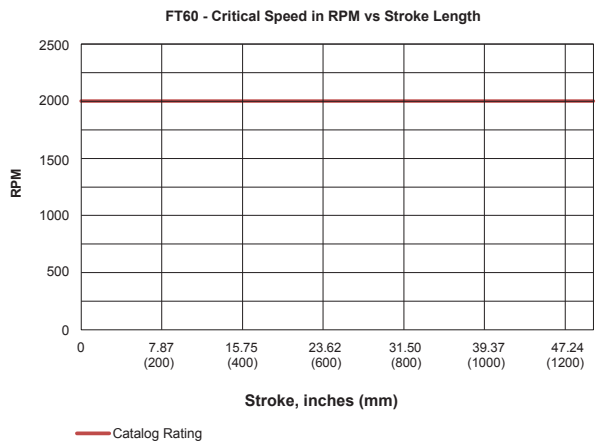
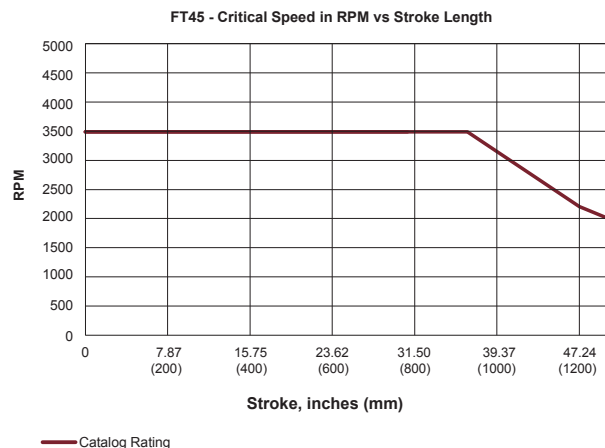
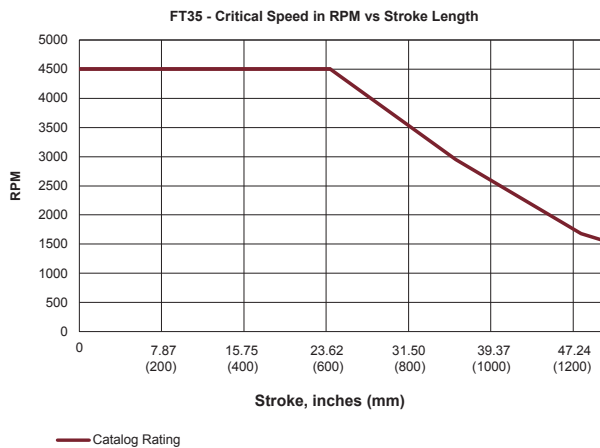

* With longer stroke length actuators, the rated speed of the actuator is determined by the critical speed

Maximum Force Rating

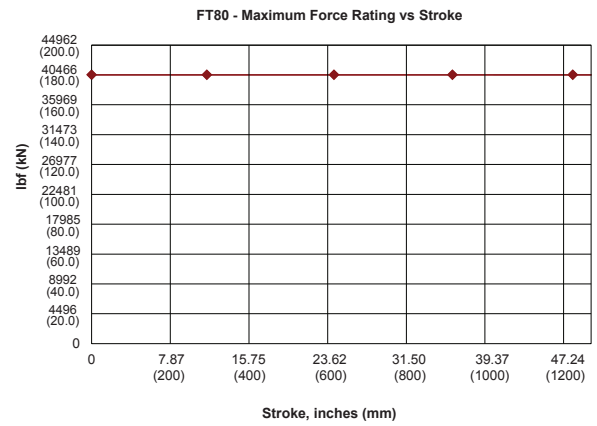
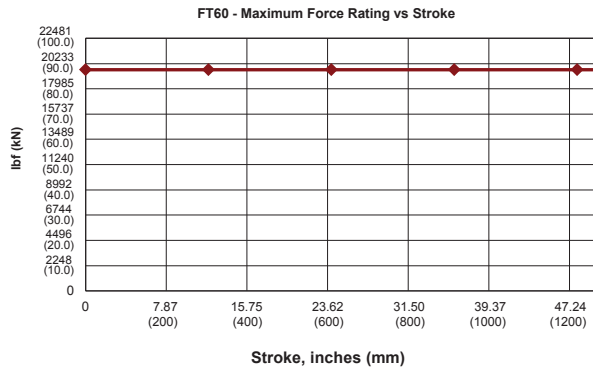
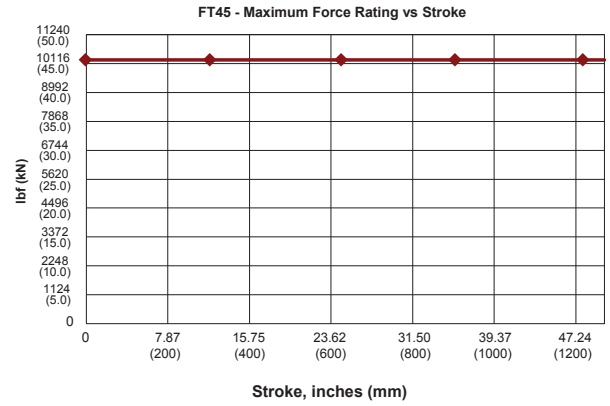
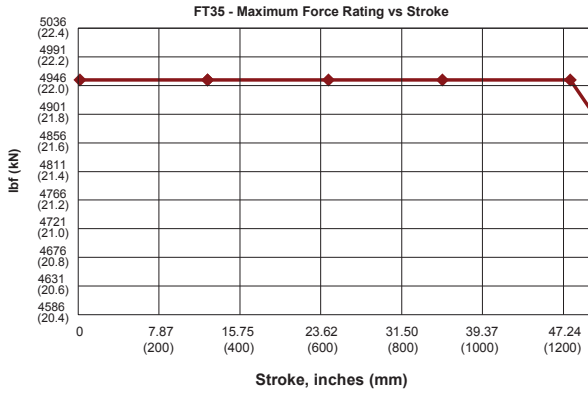

* With longer stroke length actuators, the rated speed of the actuator is determined by the critical speed

Dimensions

Base Actuator (FT35, FT60, FT80)

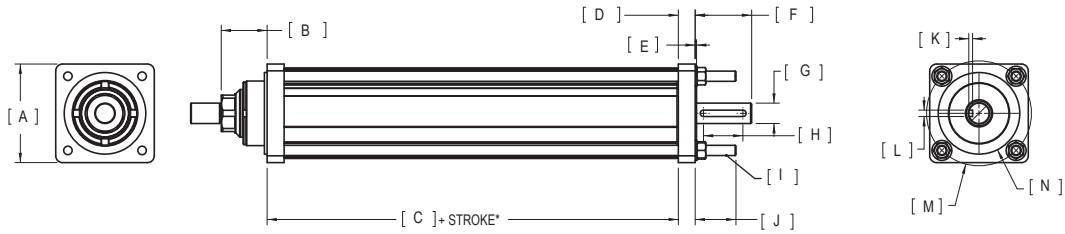

		FT35	FT60	FT80
A	in	□ 3.63	□ 6.38	□ 8.50
	mm	92.1	161.9	215.9
B	in	1.69	2.25	3.03
	mm	42.9	57.1	77.0
C	in	9.1*	15.3	19.8
	mm	232*	389	503
D	in	0.62	0.83	0.90
	mm	15.7	21.1	22.9
E	in	0.05	0.10	0.10
	mm	1.3	2.5	2.5
F	in	2.08	2.41	3.34
	mm	52.8	61.2	84.7
G	in	∅ 0.748 +0.00/-0.0005	∅ 1.378 +0.00/-0.0006	∅ 2.362 +0.00/-0.0005
	mm	19.0 +0.00/-0.013	35.0 +0.00/-0.016	60.0 +0.00/-0.013
H	in	1.45	1.60	1.48
	mm	36.8	40.5	37.5

		FT35	FT60	FT80
I	in	3/8- 16 UNC - 2A	9/16 - 12 UNC - 2A	3/4- 10 UNC - 2A
	mm	M8 x 1.25 6g	M14 x 2.0 6g	M20 x 2.5 6g
J	in	1.50	2.0	2.0
	mm	38.1	50.7	50.7
K	in	0.138 +0.004/-0.00	0.197 +0.008/-0.00	0.278 +0.005/-0.00
	mm	3.5 +0.1 0.0	5.0 +0.2 -0.0	7.0 +0.1 -0.0
L	in	0.236 -0.00/-0.002	0.3937 +0.0006/-0.0020	0.709 -0.001/-0.002
	mm	6.0 -0.012/-0.042	10.0 -0.015/-0.051	18.0 -0.018/-0.061
M	in	∅ 3.860 BC	∅ 6.79 BC	∅ 9.33 BC
	mm	98.0	172.4	237.0
N	in	∅ 3.00	∅ 5.00	∅ 6.75
	mm	76.2	127.0	171.5

*Add 20 mm if choosing high capacity option for the FT35

Base Actuator (FT45)

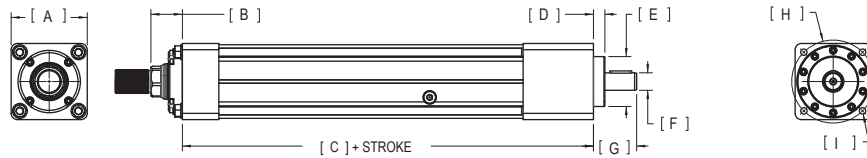

		FT45
A	in	□ 4.80
	mm	122.0
B	in	1.99
	mm	50.5
C	in	13.9
	mm	354
D	in	0.72
	mm	18.3
E	in	∅ 3.15
	mm	80.00

		FT45
F	in	∅ 1.102 +0.00/-0.0005
	mm	28.0 +0.00/-0.013
G	in	2.73
	mm	69.3
H	in	∅ 5.236 BC
	mm	133.0
I	mm	4X M12X1.75 - 6H ↓ 1.0

Pre-sale drawings and models are representative and are subject to change. Certified drawings and models are available for a fee. Consult your local Exlar representative for details.

Clevis Mount

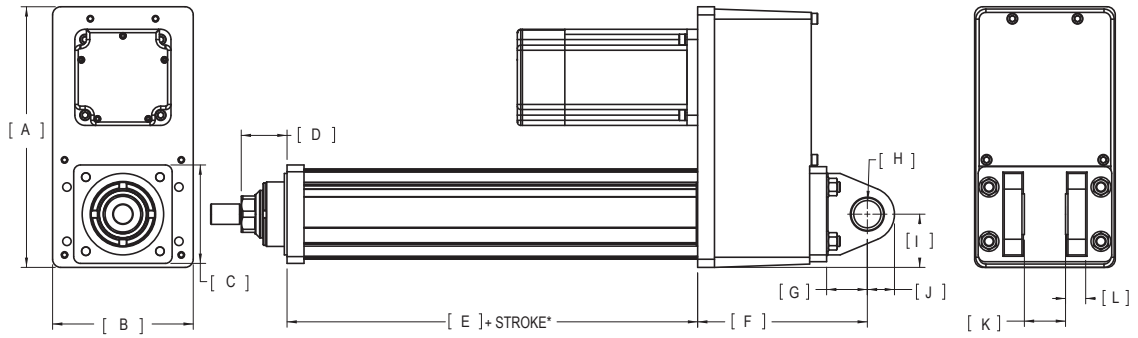

		FT35	FT45 (Option C)	FT45 (Option G)	FT60
A	in	9.60	14.55	14.55	15.55
	mm	243.8	369.5	369.5	395.0
B	in	5.18	7.48	7.48	8.53
	mm	131.6	190.0	190.0	216.7
C	in	□ 3.63	□ 4.80	□ 4.80	□ 6.38
	mm	92.1	122.0	122.0	161.9
D	in	1.69	1.99	1.99	2.25
	mm	42.9	50.5	50.0	57.1
E	in	9.1*	13.9	13.9	15.3
	mm	232*	354	354	368
F	in	6.3	9.0	7.9	9.0
	mm	159	229	201	229
G	in	1.50	2.12	1.26	2.5
	mm	38.1	53.8	32.0	63.5
H	in	∅ 1.000** +0.002 / -0.001	∅ 1.378 ±0.001	∅ 0.787 H9	∅ 1.750*** +0.002 / -0.001
	mm	25.4 +0.05 / -0.03	35.0 ±0.03	20.00 H9	44.45 +0.05 / -0.03
I	in	2.0	3.1	3.1	3.43
	mm	50	78	78	87.1
J	in	1.00	1.4	0.6	2.13
	mm	25.4	35	15	54.0
K	in	0.74	1.0	0.6	2.51
	mm	19	25	15	63.9
L	in	1.52	2.03	1.18	1.25
	mm	38.5	51.6	30.0	31.8

Parallel motor mount shown.

*Add 20 mm if choosing high capacity option for the FT35.

** If "G" metric clevis option, ∅ 27 mm + 0.00 / - 0.06

*** If "G" metric clevis option, ∅ 45 mm + 0.00 / - 0.08

FT Series Linear Actuators

Front Flange

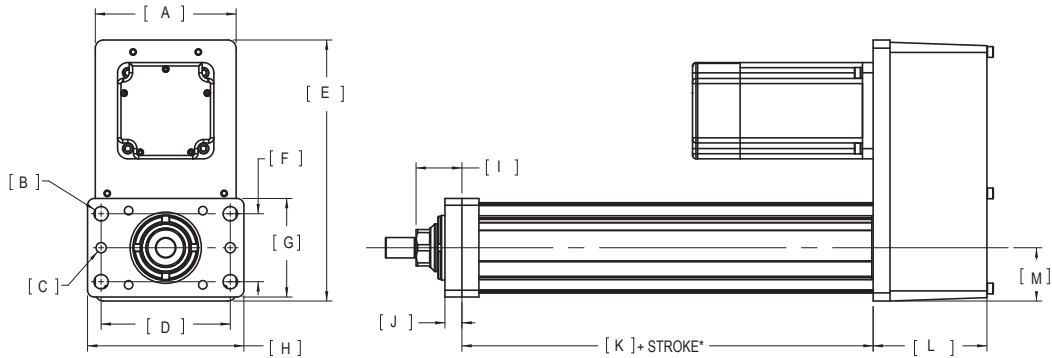

		FT35	FT45	FT60	FT80
A	in	5.18	7.48	6.82	8.77
	mm	131.6	190.0	173.2	222.8
B	in	Ø 0.53	Ø 0.69	Ø 0.66	Ø 0.78
	mm	13.5	17.5	16.7	19.8
C	in	Ø 0.375 +0.001 / -0.000	Ø 0.500 +0.001 / -0.000	Ø 0.501 +0.001 / -0.000	Ø 0.625 +0.001 / -0.000
	mm	9.53 +0.03 / 0.00	12.70 +0.03 / 0.00	12.7 +0.03 / 0.00	15.9 +0.025 / 0.000
D	in	4.75	6.38	8.32	10.75
	mm	120.7	161.9	211.2	273.1
E	in	9.6	14.55	14.32	17.33
	mm	243.8	369.5	363.7	440.2
F	in	2.50	3.82	4.57	6.00
	mm	63.5	97.0	116.2	152.4
G	in	3.63	5.00	6.38	8.50
	mm	92.1	127.0	161.9	215.9
H	in	5.8	7.63	10.00	12.75
	mm	146	193.7	254.0	323.9
I	in	1.69	1.99	2.25	3.03
	mm	42.9	50.5	57.1	77.0
J	in	0.63	1.00	1.00	1.25
	mm	15.9	25.4	25.4	31.8
K	in	9.1*	13.9	15.3	19.8
	mm	232*	354	388	503
L	in	4.19	5.26	4.6	6.43
	mm	106.3	133.7	116	163.3
M	in	1.96	3.05	3.19	4.40
	mm	49.8	77.5	81.0	111.8

*Add 20 mm if choosing high capacity option for the FT35.

Pre-sale drawings and models are representative and are subject to change. Certified drawings and models are available for a fee. Consult your local Exlar representative for details.

Rear Flange (FT35, FT60)

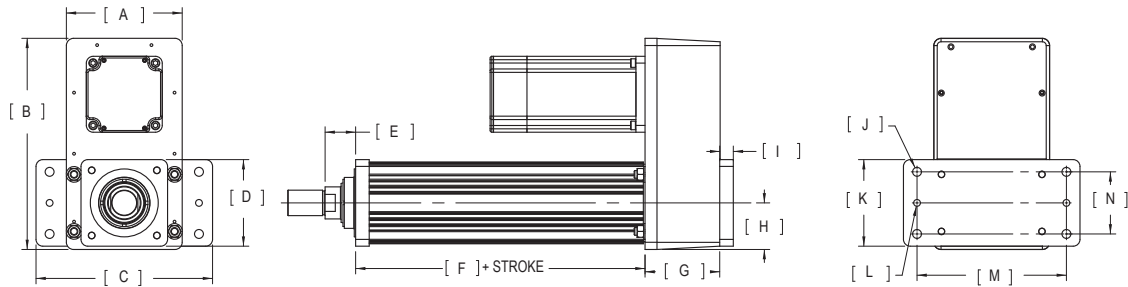

		FT35	FT60
A	in	5.18	8.53
	mm	131.6	216.7
B	in	9.60	15.55
	mm	243.8	395.0
C	in	9.00	13.00
	mm	228.6	330.2
D	in	□ 3.63	□ 6.38
	mm	92.1	161.9
E	in	1.69	2.25
	mm	42.9	57.1
F	in	9.1*	15.3
	mm	232*	388
G	in	4.13	5.50
	mm	104.8	139.7

*Add 20 mm if choosing high capacity option for the FT35

		FT35	FT60
H	in	1.96	3.43
	mm	49.8	87.1
I	in	0.63	1.00
	mm	15.9	25.4
J	in	∅ 0.53	∅ 0.66
	mm	13.5	16.7
K	in	3.5	6.38
	mm	88.9	161.9
L	in	∅ 0.375 +0.001/-0.000	∅ 0.501 +0.001/-0.000
	mm	∅ 9.53 +0.03/-0.00	12.7 +0.03/0.00
M	in	6.5	11.00
	mm	165.1	279.4
N	in	2.50	4.58
	mm	63.5	116.2

Rear Flange (FT45)

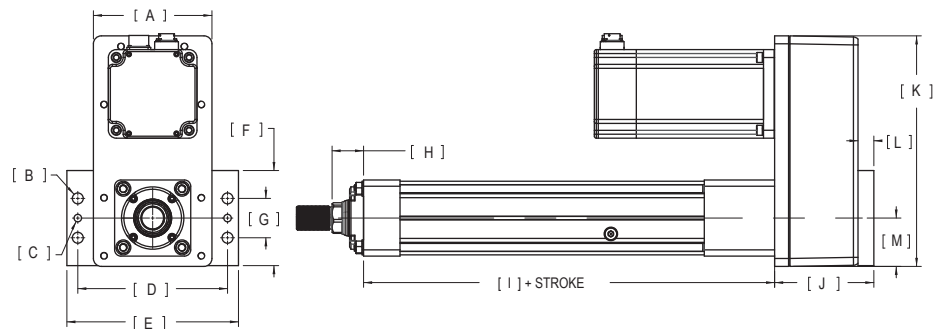

	A	B	C	D	E	F	G
in	7.48	∅ 0.69	∅ 0.472 +0.001/-0.00	9.45	10.83	6.00	2.48
mm	190.0	17.5	12.00 +0.03/0.00	240.0	275.0	152.4	63.1

	H	I	J	K	L	M
in	1.99	13.9	6.26	14.55	1.00	3.05
mm	50.5	354	159.0	369.5	25.4	77.5

Pre-sale drawings and models are representative and are subject to change. Certified drawings and models are available for a fee. Consult your local Exlar representative for details.

FT Series Linear Actuators

Trunnion Mount (FT35, FT60)

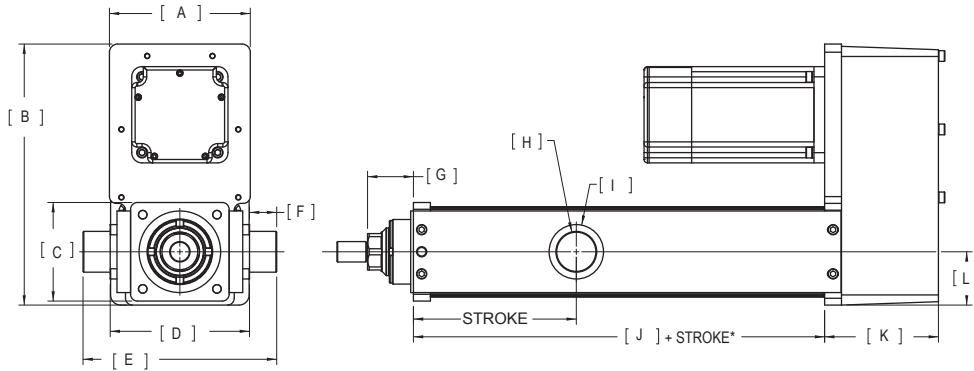

		FT35	FT60
A	in	5.18	6.82
	mm	131.6	173.2
B	in	9.60	14.32
	mm	243.8	363.7
C	in	□ 3.63	□ 6.38
	mm	92.1	161.9
D	in	5.12	8.13
	mm	130.1	206.4
E	in	7.12	12.13
	mm	180.9	308.0
F	in	1.00	2.00
	mm	25.4	50.8

		FT35	FT60
G	in	1.69	2.25
	mm	42.9	57.1
H	in	∅ 1.500** ±0.001	∅ 2.500*** ±0.001
	mm	38.1 ±0.03	63.50 ±0.03
I	in	∅ 2.00	∅ 3.50
	mm	50.8	88.9
J	in	9.1*	15.3
	mm	232*	388
K	in	4.19	4.57
	mm	106.3	116.1
L	in	1.96	3.19
	mm	49.8	81.0

*Add 20 mm if choosing high capacity option. for the FT35.

** If "Q" metric side trunnion option, ∅ 35 mm h7

*** If "Q" metric side trunnion option, ∅ 60 mm h9

Trunnion Mount (FT45)

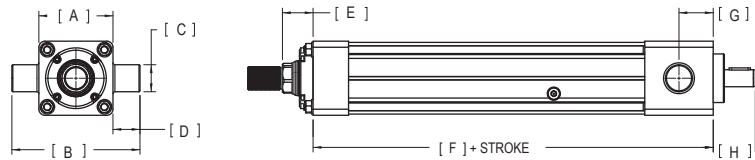

		Imperial (A or 2)	Metric (V or P)
A	in	□ 4.80	□ 4.80
	mm	122.0	122.0
B	in	8.30	7.95
	mm	210.9	202.0
C	in	∅ 1.750 +0.000/-0.002	∅ 1.969 +0.000/-0.002
	mm	44.45 0.00/-0.05	50.00 0.00/-0.05
D	in	1.75	1.57
	mm	44.5	40.00

		Imperial (A or 2)	Metric (V or P)
E	in	1.99	1.99
	mm	50.5	50.5
F	in	13.9	13.9
	mm	354	354
G	in	2.22	2.22
	mm	56.4	56.4
H	in	2.73	2.73
	mm	69.3	69.3

Pre-sale drawings and models are representative and are subject to change. Certified drawings and models are available for a fee. Consult your local Exlar representative for details.

Extended Tie Rod Mount (FT35, FT60, FT80)

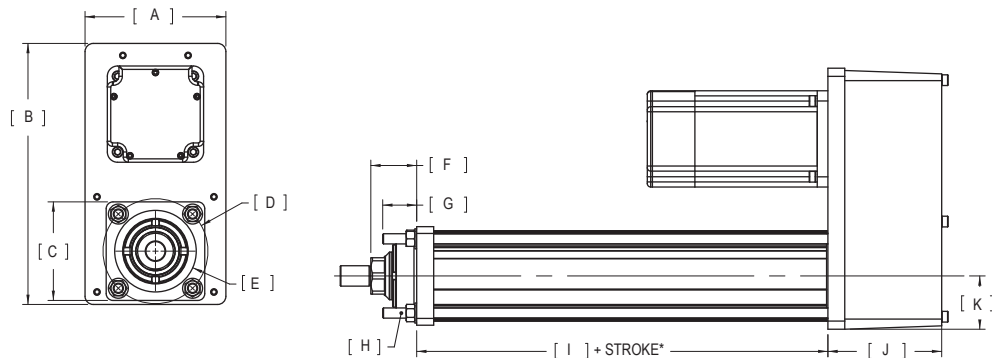

		FT35	FT60	FT80
A	in	5.18	6.82	8.77
	mm	131.6	173.2	222.8
B	in	9.60	14.32	17.33
	mm	243.8	363.7	440.2
C	in	□ 3.63	□ 6.38	□ 8.50
	mm	92.1	161.9	215.9
D	in	∅ 3.86 BC	∅ 6.79 BC	∅ 9.33 BC
	mm	98.0	172.4	237.0
E	in	∅ 3.000 +0.000/-0.002	∅ 5.000 +0.000/-0.002	∅ 6.75 +0.000/-0.002
	mm	76.20 0.00/-0.05	127.0 0.00/-0.05	171.45 0.00/-0.05
F	in	1.69	2.25	3.03
	mm	42.9	57.1	77.0

		FT35	FT60	FT80
G	in	1.25	2.00	3.50
	mm	31.8	50.8	88.9
H	in	3/8-16 UNC-2A	9/16-12 UNC-2A	3/4-10 UNC-2A
	mm	M8 x 1.25 6g	M14 x 2.0 6g	M20 x 2.5 6g
I	in	9.1*	15.3	19.8
	mm	232*	388	503
J	in	4.19	4.57	6.43
	mm	106.3	116.1	163.3
K	in	1.96	3.19	4.40
	mm	49.8	81.0	111.8

*Add 20 mm if choosing high capacity option for the FT35

Extended Tie Rod Mount (FT45)

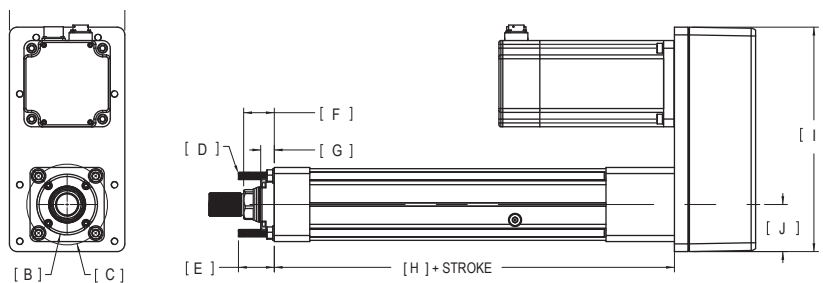

	A	B	C	D	E
in	7.48	∅ 3.937	∅ 5.236 BC	1/2-13 UNC	2.3
mm	190.0	100.00	133.00	M12 x 1.75 6g	59

	F	G	H	I	J
in	1.99	0.88	13.9	14.55	3.05
mm	50.5	22.4	354	369.5	77.5

Pre-sale drawings and models are representative and are subject to change. Certified drawings and models are available for a fee. Consult your local Exlar representative for details.

FT Series Linear Actuators

Side Lug Mount (FT35, FT60, FT80)

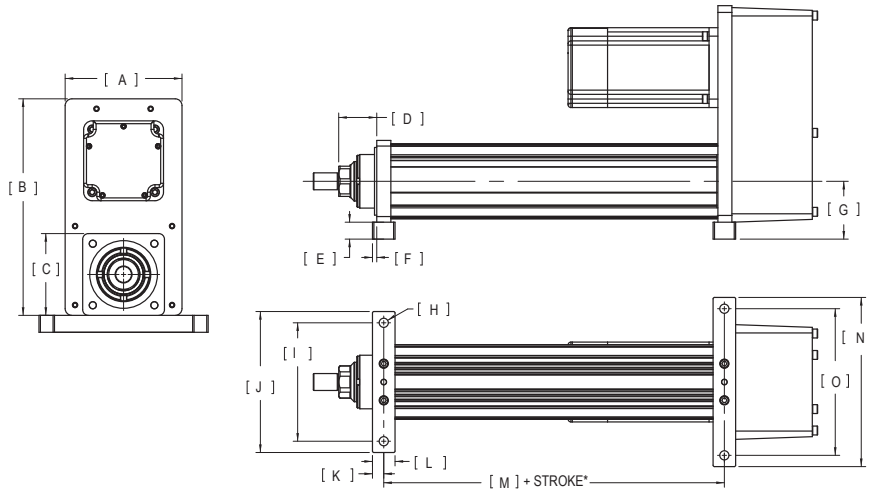

		FT35	FT60	FT80
A	in	5.18	6.82	8.77
	mm	131.6	173.2	222.8
B	in	9.60	14.32	17.33
	mm	243.8	363.7	440.2
C	in	□ 3.63	□ 6.38	□ 8.50
	mm	92.1	161.9	215.9
D	in	1.69	2.25	3.03
	mm	42.9	57.1	77.0
E	in	0.75	1.0	2.00
	mm	19.1	25.4	50.8
F	in	0.19	0.50	0.50
	mm	4.8	12.7	12.7
G	in	2.56	4.19	6.25
	mm	65.1	106.4	158.75

*Add 20 mm if choosing high capacity option for the FT35.

		FT35	FT60	FT80
H	in	Ø 0.41	Ø 0.53	Ø 0.78
	mm	10.3	13.5	19.8
I	in	5.25	8.50	12.75
	mm	133.4	215.9	323.9
J	in	6.25	10.00	10.75
	mm	158.8	254.0	273.1
K	in	0.50	1.00	1.25
	mm	12.7	25.4	31.8
L	in	1.00	2.00	2.50
	mm	25.4	50.8	63.5
M	in	9.1*	15.3	19.6
	mm	232*	388	498
N	in	7.50	10.00	12.75
	mm	190.5	254.0	323.9
O	in	6.5	8.50	10.75
	mm	165.1	215.9	273.1

Pre-sale drawings and models are representative and are subject to change. Certified drawings and models are available for a fee. Consult your local Exlar representative for details.

Side Lug Mount (FT45)

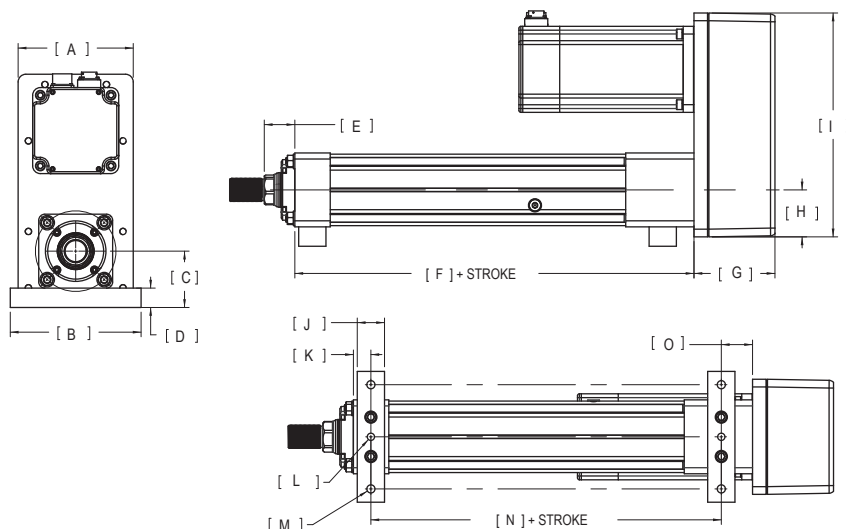

		FT45	
A	in	7.48	
	mm	190.0	
B	in	8.50	
	mm	215.9	
C	in	3.66	
	mm	93.0	
D	in	1.26	
	mm	32.0	
E	in	1.99	
	mm	50.5	
F	in	13.9	
	mm	354	
G	in	5.26	
	mm	133.6	

		FT45	
H	in	3.05	
	mm	77.5	
I	in	14.55	
	mm	369.5	
J	in	1.77	
	mm	45.0	
K	in	1.15	
	mm	29.2	
L	in	Ø 0.472 +0.001/0.000	
	mm	12.0 +0.03/0.00	
M	in	Ø 0.53	
	mm	13.5	
N	in	10.57	
	mm	269.4	
O	in	2.22	
	mm	56.4	

Pre-sale drawings and models are representative and are subject to change. Certified drawings and models are available for a fee. Consult your local Exlar representative for details.

FT Series Linear Actuators

Side Mount

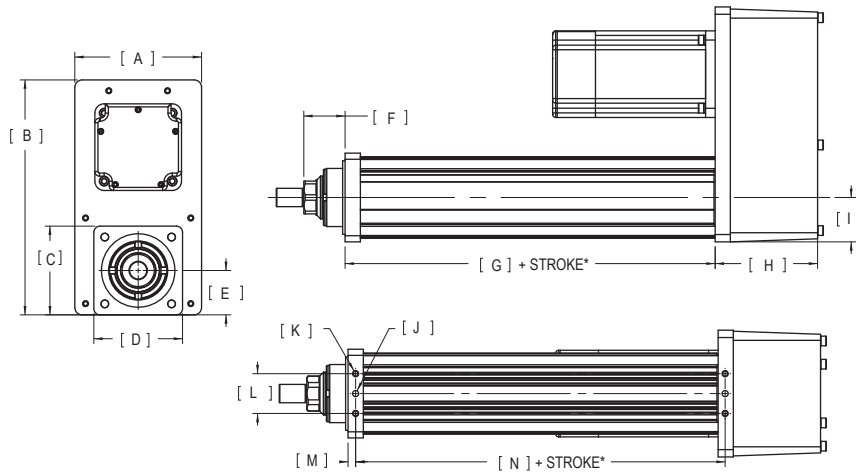

*Add 20 mm if choosing high capacity option.

		FT35	FT60	FT80
A	in	5.18	6.82	8.77
	mm	131.6	173.2	222.8
B	in	9.60	14.32	17.38
	mm	243.8	363.7	440.2
C	in	□ 3.63	□ 6.38	□ 8.50
	mm	92.1	161.9	215.9
D	in	□ 3.63	□ 6.38	□ 8.50
	mm	92.1	161.9	215.9
E	in	1.81	NA	NA
	mm	46.0	NA	NA
F	in	1.69	2.25	3.03
	mm	42.9	57.1	77.0
G	in	9.1*	15.3	19.8
	mm	232*	388	503

		FT35	FT60	FT80
H	in	4.19	4.57	6.43
	mm	106.3	116.1	163.5
I	in	1.81	3.19	4.25
	mm	46.1	81.0	108.0
J		Ø 0.2500 _↓ 0.400 ¹ +0.0000/ -0.0005	Ø 0.5000 _↓ 1.00 ² +0.0000/ -0.0005	Ø 0.6250 _↓ 1.375 ³ +0.0000/ -0.0005
		1/4-20 UNC- 2B ↓ .63 ¹	1/2-13 UNC-2B ↓ 1.13 ²	5/8-11 UNC- 2B ↓ 1.25 ³
L	in	1.63	2.50	4.00
	mm	41.3	63.5	101.6
M	in	0.31	0.50	0.75
	mm	8	12.7	19.1
N	in	9.1*	15.3	19.6
	mm	232*	388	498

*Add 20 mm if choosing high capacity option for the FT35.

¹ If "J" or "K" metric side mount options, M6 x 1.0 ↓ 9 mm with Ø 6 mm M7 ↓ 9 mm dowel hole

² If "J" or "K" metric side mount options, M12 x 1.75 ↓ 19 mm with Ø 12 mm M7 ↓ 12 mm Dowel Hole

³ If "J" or "K" metric side mount options, M16 x 2.0 ↓ 16 mm with Ø 12 mm M7 ↓ 12 mm dowel hole

Rear Eye Mount

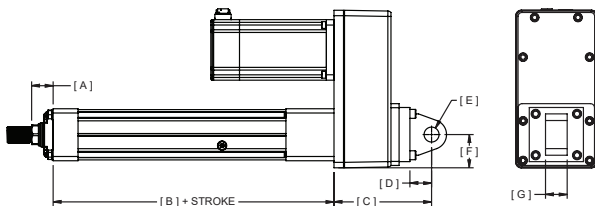

		FT45 (Option Y)	FT45 (Option W)
A	in (mm)	1.99 (50.5)	1.99 (50.5)
B	in (mm)	13.9 (354)	13.9 (354)
C	in (mm)	9.01 (228.9)	7.90 (200.7)
D	in (mm)	2.00 (50.8)	1.26 (32.0)
E	in (mm)	1.378 ± 0.001 (35.0 ± 0.03)	0.787 H9 (20.00 H9)
F	in (mm)	3.07 (77.9)	3.07 (77.9)
G	in (mm)	2.00 (50.8)	1.18 (30.0)

Pre-sale drawings and models are representative and are subject to change. Certified drawings and models are available for a fee. Consult your local Exlar representative for details.

Rod Ends

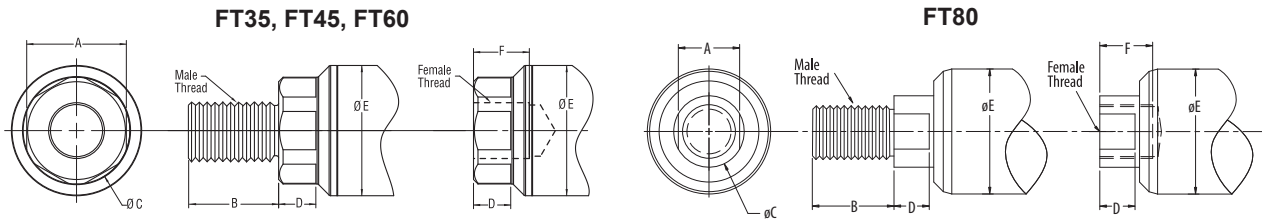

	A	B	ØC	D	ØE	F	Male U.S.	Male Metric	Female U.S.	Female Metric
FT35	1.34 (34)	1.125 (28.6)	1.434 (36.4)	0.50 (12.7)	1.750 (44.5)	0.750 (19.1)	3/4-16 UNF-2A	M16x1.5 6g	3/4-16 UNF-2B	M16x1.5 6h
FT45	1.81 (46.0)	2.25 (57.2)	2.0 (50.8)	0.63 (15.9)	2.250 (57.2)	1.50 (38.1)	1 1/2-12 UN-2A	M36x3 6g	1 1/2-12 UN-2B	M36x3 6h
FT60	2.36 (60.0)	2.750 (69.9)	2.360 (59.9)	0.750 (19.1)	3.000 (76.2)	2.000 (50.8)	1 7/8-12 UN-2A	M42x4.5 6g	1 7/8-12 UN-2B	M42x4.5 6h

	A	B	ØC	D	ØE	F	Male U.S.	Male Metric	Female U.S.	Female Metric
FT80	2.75 (69.9)	4.019 (102.1)	3.143 (79.8)	1.000 (25.4)	4.000 (101.6)	2.250 (57.2)	2 1/2-12 UN-2A	M56x5.5 6g	2 1/2-12 UN-2B	M56x5.5 6h

Dimensions shown in inches (mm)

Case Dimensions

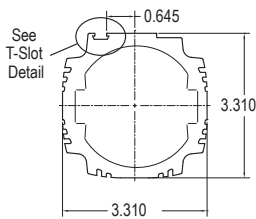

FT35

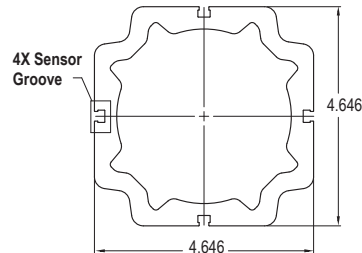

FT45

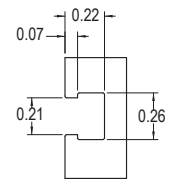

Detail 4X Sensor Groove

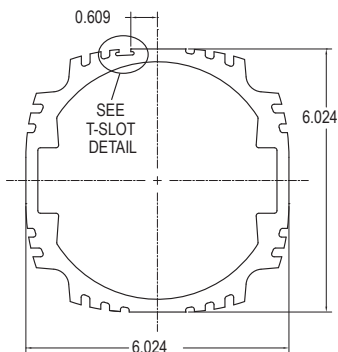

FT60

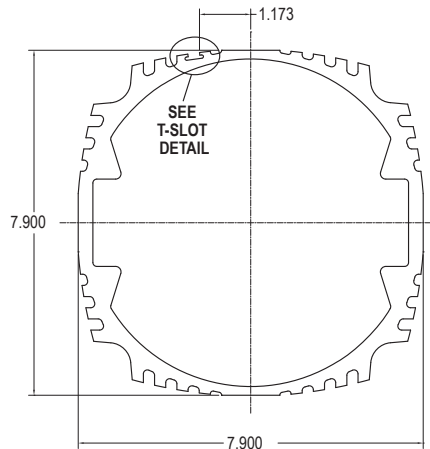

FT80

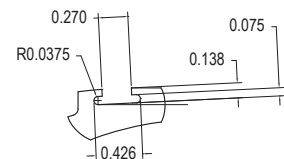

T-Slot Detail

Pre-sale drawings and models are representative and are subject to change. Certified drawings and models are available for a fee. Consult your local Exlar representative for details.

FT Series Linear Actuators

Motor Mount Drawing

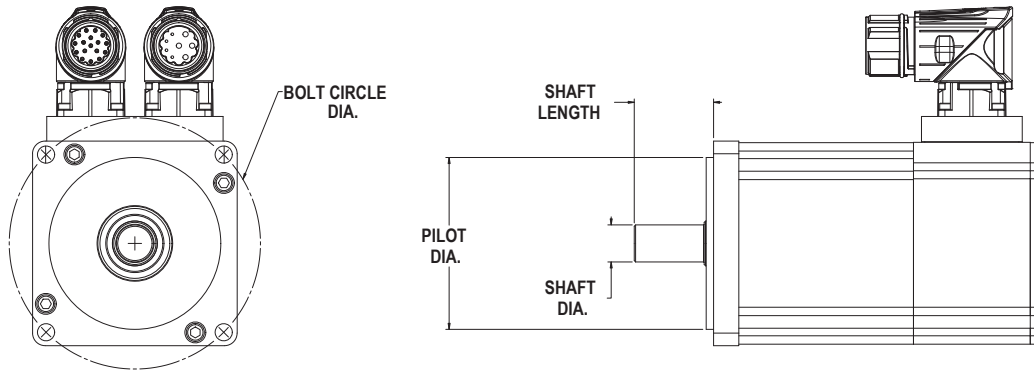

FT35 Motor Mount Codes

Bolt Circle Diameter (mm)	Pilot Diameter (mm)	Shaft Diameter (mm)	Shaft Length (mm)	Key Width (mm)	Motor Mount Code
68	60	12	30	4	GFB
68	60	16	48	5	GFA
70	50	14	30	5	JGA
70	50	16	30	5	GGB
70	50	16	36	5	EGB
70	50	16	40	5	GGA
75	60	14	30	5	IHB
75	60	16	32	5	GHB
75	60	16	48	5	GHA
85	70	16	37	5	GIB
85	70	22	56	6	GIA
90	60	19	40	6	JKF
90	70	14	30	5	JKD
90	70	16	35	NA	JKC
90	70	16	40	5	JKG
90	70	19	40	6	JKA
95	50	14	30	5	ELC
95	65	14	30	5	ELA
95	65	16	30	5	ELB
100	50	16	31	6	GMC
100	80	14	30	5	IMA
100	80	14	40	5	JMC
100	80	16	40	5	IMB
100	80	19	40	6	IMC
100	80	19	55	6	JMD
100	80	20	40	6	GMB
100	80	22	48	6	GMA
115	95	19	40	6	INA
115	95	19	55	6	JNC

Bolt Circle Diameter (mm)	Pilot Diameter (mm)	Shaft Diameter (mm)	Shaft Length (mm)	Key Width (mm)	Motor Mount Code
115	95	22	45	8	JND
115	95	22	70	NA	JNB
115	95	24	45	8	JNA
115	95	24	50	8	INB
120	60	22	39	6	G7C
120	90	22	46	6	G7B
130	95	19	40	6	IPC
130	95	24	50	8	IPD
130	110	19	40	6	IPA
130	110	24	50	8	IPB
140	110	32	64	10	E5A
145	110	19	40	6	JQJ
145	110	19	55	5	JQG
145	110	19	55	6	JQK
145	110	22	55	8	JQH
145	110	22	55	6	JQF
145	110	22	70	8	JQE
145	110	24	55	8	JQD
145	110	24	65	8	JQC
145	110	28	55	8	JQB
145	110	28	63	8	JQA
165	95	24	50	8	IRG
165	110	24	50	8	IRF
165	130	24	50	8	IRA
165	130	28	60	8	IRB
165	130	32	50	10	IRD
165	130	32	58	10	IRC
165	130	32	80	10	IRE
165	130	32	80	10	IRE

FT45 Motor Mount Codes

Bolt Circle Diameter (mm)	Pilot Diameter (mm)	Shaft Diameter (mm)	Shaft Length (mm)	Key Width (mm)	Motor Mount Code
85	70	22	49	6	GIA
95	65	16	30	5	ELB
100	50	16	31	6	GMC
100	80	14	30	5	IMA
100	80	14	40	5	JMC
100	80	16	40	5	IMB
100	80	19	40	6	IMC
100	80	19	55	6	JMD
100	80	20	40	6	GMB
100	80	22	52	6	GMA
115	95	19	40	6	INA
115	95	19	55	6	JNC
115	95	22	45	8	JND
115	95	22	70	NA	JNB
115	95	24	45	8	JNA
115	95	24	50	8	INB
120	60	22	39	6	G7C
120	90	22	46	6	G7B
120	90	32	88	10	G7A
120	100	32	85	10	G7D
130	95	19	40	6	IPC
130	95	24	50	8	IPD
130	110	19	40	6	IPA
130	110	24	50	8	IPB
140	110	32	64	10	E5A
145	110	19	55	5	JQG
145	110	19	55	6	JQK
145	110	22	55	8	JQH

Bolt Circle Diameter (mm)	Pilot Diameter (mm)	Shaft Diameter (mm)	Shaft Length (mm)	Key Width (mm)	Motor Mount Code
145	110	22	55	6	JQF
145	110	22	70	8	JQE
145	110	24	58	8	JQD
145	110	24	65	8	JQC
145	110	28	55	8	JQB
145	110	28	63	8	JQA
165	95	24	50	8	IRG
165	110	24	50	8	IRF
165	130	24	50	8	IRA
165	130	28	60	8	IRB
165	130	32	50	10	IRD
165	130	32	58	10	IRC
165	130	32	80	10	IRE
190	155	32	60	10	I2A
200	114.3	22	55	6	JSE
200	114.3	28	55	8	JSF
200	114.3	35	70	10	JSB
200	114.3	35	79	10	JSA
200	114.3	42	113	10	JSD
200	114.3	42	113	NA	JSG
215	130	32	60	10	ITE
215	180	24	50	10	ITA
215	180	28	60	10	ITB
215	180	32	58	10	ITC
215	180	32	80	10	ITD
215	180	38	80	10	ITF
215	180	42	82	12	ITG
215	180	42	82	12	ITG

FT60 Motor Mount Codes

Bolt Circle Diameter (mm)	Pilot Diameter (mm)	Shaft Diameter (mm)	Shaft Length (mm)	Key Width (mm)	Motor Mount Code
100	50	16	31	6	GMC
100	80	20	40	6	GMB
100	80	22	48	6	GMA
115	95	19	40	6	INA
115	95	19	55	6	JNC
115	95	22	45	8	JND
115	95	22	70	NA	JNB
115	95	24	45	8	JNA
115	95	24	50	8	INB
120	60	22	39	6	G7C
120	90	22	46	6	G7B
120	90	32	88	10	G7A
120	100	32	85	10	G7D
120	130	40	112	12	G7E
130	95	19	40	6	IPC
130	95	24	50	8	IPD
130	110	19	40	6	IPA
130	110	24	50	8	GPC
130	110	24	50	8	IPB
130	110	25	55	8	GPB
130	110	32	65	10	GPA
140	110	32	64	10	E5A
145	110	19	55	5	JQG
145	110	19	55	6	JQK
145	110	22	55	8	JQH
145	110	22	55	6	JQF
145	110	22	70	8	JQE
145	110	24	58	8	JQD
145	110	24	65	8	JQC

Bolt Circle Diameter (mm)	Pilot Diameter (mm)	Shaft Diameter (mm)	Shaft Length (mm)	Key Width (mm)	Motor Mount Code
145	110	28	55	8	JQB
145	110	28	63	8	JQA
165	80	32	63	10	GRE
165	95	24	50	8	IRG
165	110	24	50	8	IRF
165	130	24	50	8	IRA
165	130	28	60	8	IRB
165	130	32	50	10	IRD
165	130	32	58	10	IRC
165	130	32	72	10	GRD
165	130	32	80	10	IRE
165	130	40	80	12	GRB
165	130	40	97	12	GRC
165	130	40	112	12	GRA
190	155	32	60	10	I2A
200	114.3	22	55	6	JSE
200	114.3	28	55	8	JSF
200	114.3	35	70	10	JSB
200	114.3	35	80	10	JSA
200	114.3	42	113	10	JSD
200	114.3	42	113	12	JSG
215	130	32	60	10	ITE
215	180	24	50	10	ITA
215	180	28	60	10	ITB
215	180	32	58	10	ITC
215	180	32	80	10	ITD
215	180	38	80	10	ITF
215	180	42	85	12	ITG

FT80 Motor Mount Codes

Bolt Circle Diameter (mm)	Pilot Diameter (mm)	Shaft Diameter (mm)	Shaft Length (mm)	Key Width (mm)	Motor Mount Code
130	110	24	50	8	GPC
130	110	25	55	8	GPB
130	110	32	72	10	GPA
165	80	32	63	10	GRE
165	95	24	50	8	IRG
165	110	24	50	8	IRF
165	130	24	50	8	IRA
165	130	28	60	8	IRB
165	130	32	50	10	IRD
165	130	32	58	10	IRC
165	130	32	72	10	GRD
165	130	32	80	10	IRE
165	130	40	80	12	GRB
165	130	40	102	12	GRC
165	130	40	112	12	GRA
190	155	32	60	10	I2A
200	114.3	28	55	8	JSF
200	114.3	35	70	10	JSB
200	114.3	35	80	10	JSA
200	114.3	42	113	10	JSD
200	114.3	42	113	12	JSG
215	130	32	60	10	ITE

Bolt Circle Diameter (mm)	Pilot Diameter (mm)	Shaft Diameter (mm)	Shaft Length (mm)	Key Width (mm)	Motor Mount Code
215	160	40	100	12	GTC
215	160	55	112	16	GTA
215	180	24	50	10	ITA
215	180	28	58	10	ITB
215	180	32	58	10	ITC
215	180	32	80	10	ITD
215	180	38	80	10	ITF
215	180	42	82	12	ITG
235	200	35	70	10	JUC
235	200	42	85	12	JUB
235	200	42	116	12	JUD
235	200	55	116	16	JUA
265	230	38	80	10	IVA
265	230	38	110	10	IVB
265	230	42	110	12	IVC
265	230	55	110	16	JVA
265	230	60	140	18	JVC
265	230	65	140	18	JVB
300	250	48	82	14	IWB
300	250	48	112	14	IWA
300	250	60	140	18	JWA

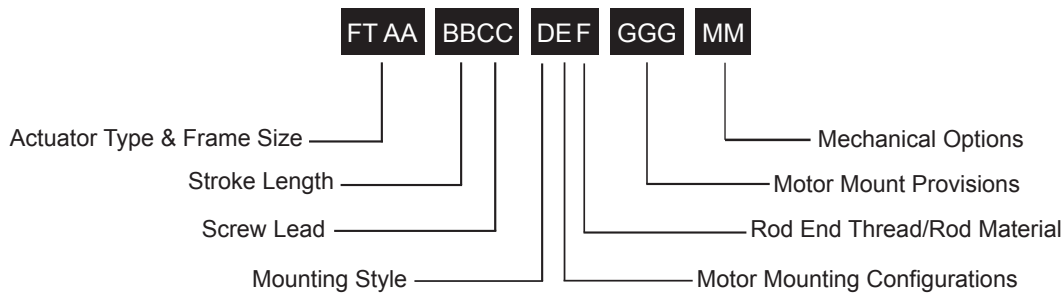

AA = FT Frame Size

- 35 = 3.5 inch (90 mm)
- 45 = 4.7 inch (120 mm)
- 60 = 5.9 inch (150 mm)
- 80 = 7.9 inch (200 mm)

BB = Stroke Length

- 06 = 6 inch (152 mm) FT35, FT45
- 12 = 12 inch (305 mm) FT35, 45, 60, 80
- 18 = 18 inch (457 mm) FT35, 45
- 24 = 24 inch (610 mm) FT35, 45, 60, 80
- 36 = 36 inch (914 mm) FT35, 45, 60, 80
- 48 = 48 inch (1219 mm) FT35, 45, 60, 80

CC = Screw Lead

- 05 = 0.2 inch, FT35, 45
- 06 = 0.23 inch, FT60, 80
- 10 = 0.39 inch, FT35, 45
- 12 = 0.47 inch, FT60, 80
- 20 = 0.79 inch, FT35
- 30 = 1.18 inch, FT60, 80

D = Mounting Style ¹

- N = None
- F = Front flange, English
- Z = Front flange, Metric, FT45
- R = Rear flange, English ^{4,5}
- C = Rear clevis, English ^{4,5}
- G = Rear clevis, Metric ^{4,5}
- Y = Rear eye, English ⁴, FT45
- W = Rear eye, Metric ⁴, FT45
- L = Side lugs
- S = Side mount, English FT35, 60, 80
- J = Side mount, Metric FT35, 60, 80
- T = Side trunnion mount, English ^{5,6} FT35, 60, 80
- Q = Side trunnion mount, Metric ^{5,6} FT35, 60, 80
- 2 = Rear trunnion mount, English, FT45
- P = Rear trunnion mount, Metric, FT45
- E = Extended tie rods, English
- M = Extended tie rods, Metric

E = Motor Mounting Configurations ³

- N = None
- I = Inline direct drive (includes Exlar standard coupling)
- P = Parallel, 1:1 belt reduction
- Q = Parallel, 2:1 belt reduction

F = Rod End

- M = Male, US standard thread
- A = Male, metric thread
- F = Female, US standard thread
- B = Female, metric thread

GGG = Motor Mount Provisions ^{3,4}

See page 114-117 for Motor Mount Code.

MM = Mechanical Options ²

- XT = High capacity roller screw

Limit Switches

See Page 100 for Limit Switch details

Please provide a 3D CAD Model of motor dimensions with all orders to insure proper mounting compatibility.



For options or specials not listed above or for extended temperature operation, please contact Exlar

NOTES:

1. Mounting face size, shaft length and other details of particular motors may require special adapters or provisions for mounting. Always discuss your motor selection with your local sales representative.
2. For extended temperature operation consult factory for model number.
3. MAX Std. motor size: FT35: 5.6 inch/165 mm, FT45: 7.1 inch/215 mm, FT60: 7.9 inch/215 mm, FT80: 8.5 inch/300 mm
For oversized motors, contact your local sales representative.
4. Not available with inline motor mount, contact your local sales representative.
5. Application details must be approved for use with an FT80.
6. IP65 environmental sealing option not available.

Contact your local sales representative regarding all special actuator components.

[Return to Table of Contents](#)

KX SERIES

MEDIUM FORCE ROLLER SCREW ACTUATOR

Mount virtually any servo motor

Long stroke lengths available

High speed and long life

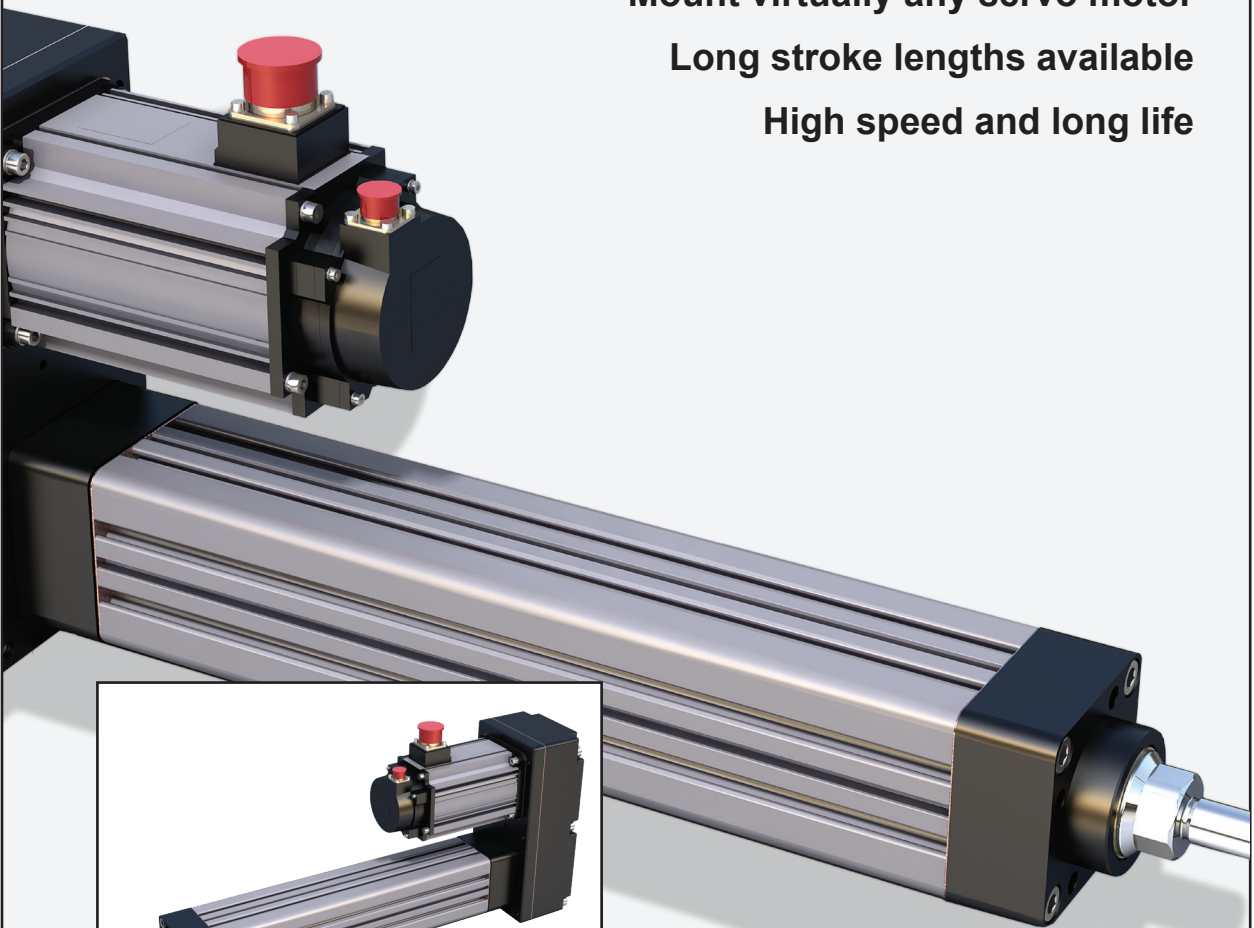

*Motors shown in photos
are for illustrative purposes
only and are not included
with KX Series Actuators*

KX Series

Linear Actuators

Exlar KX Series actuators offer advanced roller screw technology in varying performance levels and allow the use of third-party motors.

A Universal Design for Ultimate Flexibility

The KX Series actuator provides an ideal replacement for pneumatic and hydraulic cylinders in linear motion control applications. Unlike most suppliers who employ ballscrews, Exlar KX Series linear actuators utilize a planetary roller screw, assuring long life and high resistance to shock. This feature makes Exlar actuators far superior to alternative methods for applying all-electric linear actuation in industrial and military applications.

KX Series actuators are offered in 60, 75 and 90 mm frame sizes with dimensions and form-factor consistent with ISO Metric pneumatic cylinder specifications. This allows convenient substitution of Exlar actuators for existing pneumatic and hydraulic actuators.

KX Series actuators provides high performance planetary roller screw performance that is far superior to any other available rotary-to-linear conversion technologies. The KX Series is the ideal choice for demanding applications in industrial automation, mobile equipment, military, process control, or many other applications where millions of inches of travel under load is expected.

Operating Conditions and Usage

Operating Conditions and Usage		
Efficiency:		
Motor Inline	%	80
Motor Parallel	%	80
Ambient Conditions:		
Standard Ambient Temperature	°C	0 to 65
Extended Ambient Temperature*	°C	-30 to 65
Storage Temperature	°C	-40 to 85
IP Rating		IP65S

*Consult Exlar for extended temperature operation.

Technical Characteristics

Frame Sizes in (mm)	2.3 (60), 2.9 (75), 3.5 in (90)
Screw Leads in (mm)	0.19 (5), 0.4 (10)
Standard Stroke Lengths in (mm)	5.9 (150), 11.8 (300), 23.6 (600), 35.4 (900)
Force Range	up to 3,500 lbf (15 kN)
Maximum Speed	up to 32.8 in/sec (833 mm/s)

		KX60	KX75	KX90
Screw Lead Error	µm/1000 mm (in/ft)	G9: 200 (0.0024)	G9: 200 (0.0024)	G9: 200 (0.0024)
Screw Lead Backlash	mm (in)	0.10 (0.004)	0.10 (0.004)	0.10 (0.004)
Friction Torque Values	(Nm) lbf-in	0.34 (3)	0.56 (5)	0.56 (5)

The Exlar Advantage

Universal Mounting Options

The KX Series offers a wide variety of fixed and adjustable mounting accessories consistent with NFPA inch and ISO Metric pneumatic cylinder standards. The mounting options include:

- Front Flange
- Adjustable Side Trunnions
- Rear Clevis

Standard Actuator Construction

The standard KX Series actuator design includes an anodized aluminum housing offering a high level of corrosion resistance in many environments. The standard main rod is plated steel with a stainless steel rod end insert, providing excellent wear characteristics.

Sealed Body Design

The standard body design of the KX Series provides an IP54S sealed housing. IP65S sealing is standard when an inline or parallel motor mount is specified. This feature allows the actuator to be used in applications where water spray is present.

Motor Mounting Options

The KX Series allows for complete flexibility in the type and style of motor to drive the actuator. Types of motors compatible with KX Series actuators include DC motor, stepper, and servo motors. The KX Series can be ordered as a base unit without motor mounting, allowing you to manufacture your own mount.

For convenience these actuators are available with preconfigured motor mounts. Exlar maintains a large library of motor mounting dimension information for most manufacturers' servos and stepper motors.

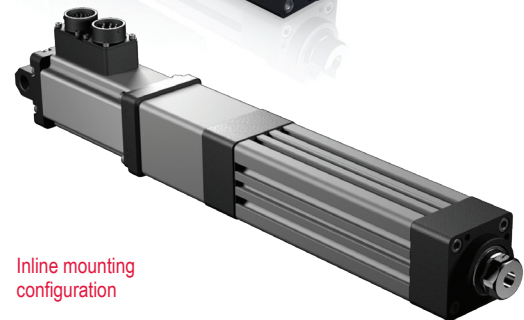
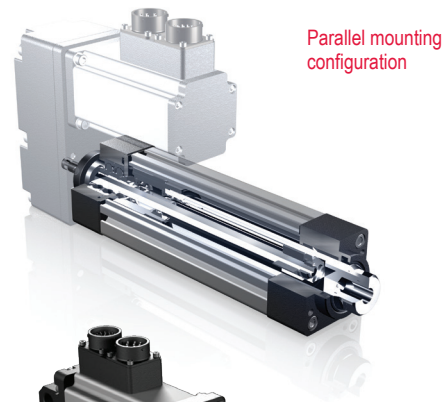

The inline mount places the motor on the input end of the actuator and allows the most compact form factor. In addition, Exlar offers a clevis mount attached to the rear of the inline-mounted motor for rear mounting.

The parallel motor mounts (side mount) utilize a belt drive system to transmit the motor torque to the actuator input shaft. Belt reductions of 1:1 and 2:1 are offered, allowing you to conveniently match the speed and output force to properly apply your KX Series actuator to your specific application.

KX Series Linear Actuators

Product Features

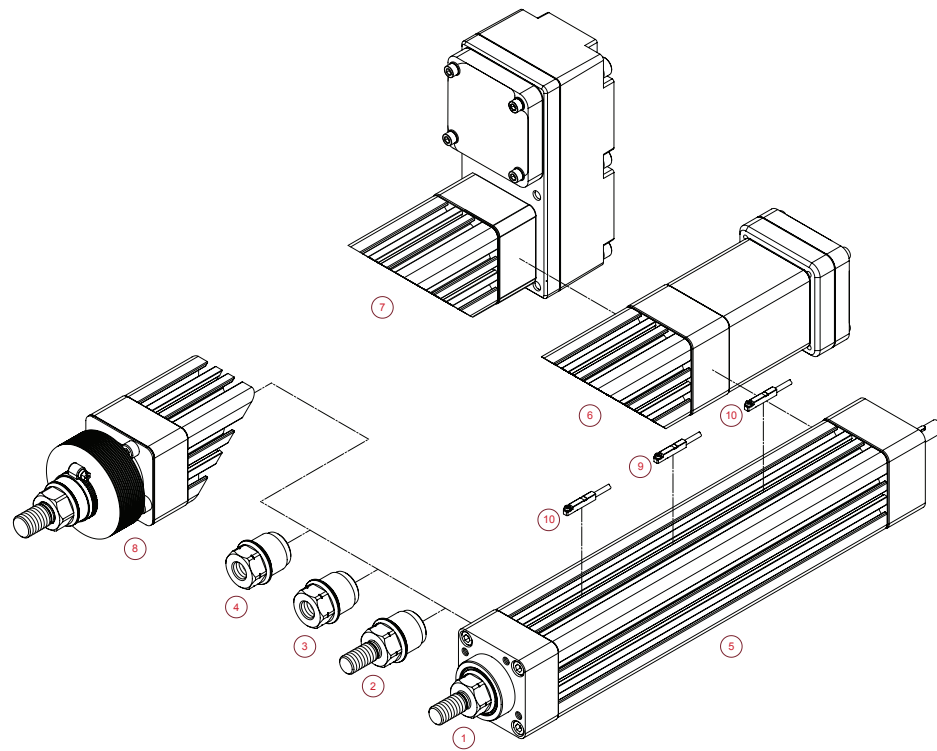
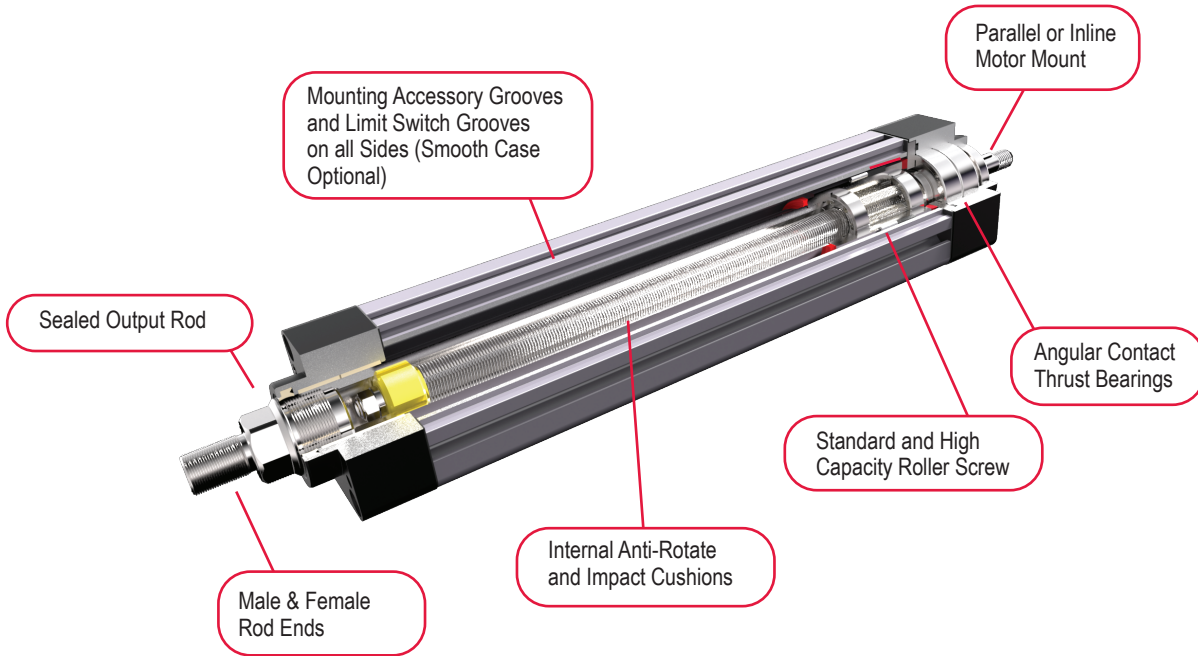

- 1-Male, US Standard thread
- 2-Male Metric thread
- 3-Female US Standard thread
- 4-Female Metric thread
- 5-Drive shaft only, no motor mount
- 6-Inline, includes shaft coupling
- 7-Parallel, 1:1 belt reduction
- 8-Protective bellows for extending rod
- 9-External Limit Switches - N.O., PNP
- 10-External Limit Switches - N.C., PNP

Industries and Applications

Hydraulic cylinder replacement
Ball screw replacement
Pneumatic cylinder replacement

Automotive

Dispensing
Automated assembly
Clamping

Food Processing

Packaging machinery
Pick and place systems

Machining

Automated flexible fixturing
Machine tool
Parts clamping
Automatic tool changers

Entertainment / Simulation

Motion simulators
Ride automation

Medical Equipment

Volumetric pumps

Plastics

Cut-offs
Die cutters
Molding
Formers

Material Handling

Indexing stages
Product sorting
Material cutting
Open / close doors
Web guidance
Wire winding
Pressing

Test

Test stands

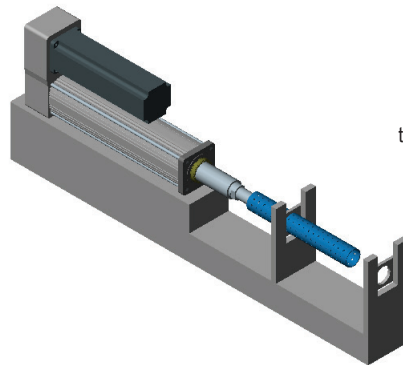

The smooth and accurate motion of Exlar's actuators combined with today's servo technology make multiple degree of freedom motion simulation applications easier to implement, cleaner and more efficient than hydraulic solutions.

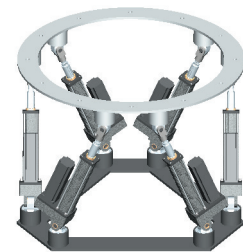

DEFINITIONS:

Maximum Force: Calculated Cubic Mean Load for the application should not exceed this value. (Values are derived from the design capacity of the FT Series actuator and should not be exceeded or relied upon for continuous operation.)

Life at Maximum Force: Estimated life that can be expected from the actuator when running at Maximum Force for intermittent periods of time. (Theoretical calculation based on the Dynamic Load Rating of the actuator and using the Maximum Force rating as the Cubic Mean Load.)

C_a (Dynamic Load Rating): A design constant used when calculating the estimated travel life of the roller screw.

Maximum Input Torque: The torque required at the screw to produce the Maximum Force rating. Exceeding this value can cause permanent damage to the actuator.

Maximum Rated RPM: The maximum allowable rotational screw speed determined by either screw length limitations or the rotational speed limit of the roller screw nut.

Maximum Linear Speed: The linear speed achieved by the actuator when Maximum Rated RPM is applied to the roller screw input shaft.

Mechanical Specifications

KX60

Models	KX		
	05	10	
Screw Lead	in	0.1969	0.3937
	mm	5	10
Maximum Force ³	lbf	1350	675
	kN	6.0	3.0
Life at Maximum Force ¹	in x 10 ⁶	1.6	18.2
	km	41.7	461.4
C _a (Dynamic Load Rating)	lbf	2738	2421
	kN	12.2	10.8
Maximum Input Torque ²	lbf-in	53	53
	Nm	6	6
Max Rated RPM @ Input Shaft	RPM	5000	5000
Maximum Linear Speed @ Maximum Rated RPM	in/sec	16.4	32.8
	mm/sec	417	833

- See page 169 for life calculation information.
- Input torque should be limited such that Max Force is not exceeded. For a parallel belt ratio, the input torque ratings must be divided by the belt ratio for allowable motor torque. The output force ratings remain the same.
- Maximum allowable actuator-generated force that can be applied routinely. Exceeding this force may result in permanent damage to the actuator. For maximum allowable externally-applied axial forces, consult factory. For high force, short stroke applications, consult factory.

Weights kg (lbs)

Base Actuator Weight (Zero Stroke)	lb	3.7
	kg	1.7
Actuator Weight Adder (Per mm of Stroke)	lb	0.017
	kg	0.008
Adder for Inline (excluding motor)	0.42 (0.93)	
Adder for Parallel Drive (excluding motor)	0.73 (1.6)	
Adder for Front Flange	0.42 (0.93)	
Adder for Rear Clevis	0.44 (0.98)	
Adder for Two Trunnions	0.37 (0.82)	

KX60 Inertias kg-m² (lbf-in-sec²)

	5 mm Lead	Add per 25 mm, 5 mm Lead
Base Unit - Input Drive Shaft Only	1.480 x 10 ⁻⁵ (1.31 x 10 ⁻⁴)	1.022 x 10 ⁻⁶ (9.045 x 10 ⁻⁶)
Inline Unit - w/Motor Coupling	2.702 x 10 ⁻⁵ (2.39 x 10 ⁻⁴)	1.022 x 10 ⁻⁶ (9.045 x 10 ⁻⁶)
	10 mm Lead	Add per 25 mm, 10 mm Lead
Base Unit - Input Drive Shaft Only	1.616 x 10 ⁻⁵ (1.43 x 10 ⁻⁴)	1.173 x 10 ⁻⁶ (1.038 x 10 ⁻⁶)
Inline Unit - w/Motor Coupling	2.837 x 10 ⁻⁵ (2.51 x 10 ⁻⁴)	1.173 x 10 ⁻⁶ (1.038 x 10 ⁻⁶)
Parallel Drive Inertias (P10 Option)		
	5 mm Lead	Add per 25 mm, 5 mm Lead
1:1 Reduction Parallel Belt Drive (66 mm)	4.339 x 10 ⁻⁵ (3.84 x 10 ⁻⁴)	1.022 x 10 ⁻⁶ (9.045 x 10 ⁻⁶)
1:1 Reduction Parallel Belt Drive (86 mm)	7.378 x 10 ⁻⁵ (6.53 x 10 ⁻⁴)	1.022 x 10 ⁻⁶ (9.045 x 10 ⁻⁶)
1:1 Reduction Parallel Belt Drive (96 mm)	8.564 x 10 ⁻⁵ (7.58 x 10 ⁻⁴)	1.022 x 10 ⁻⁶ (9.045 x 10 ⁻⁶)
2:1 Reduction Parallel Belt Drive (96 mm)	7.095 x 10 ⁻⁵ (6.28 x 10 ⁻⁴)	2.555 x 10 ⁻⁷ (2.261 x 1 ⁻⁶)
	10 mm Lead	Add per 25 mm, 10 mm Lead
1:1 Reduction Parallel Belt Drive (66 mm)	4.474 x 10 ⁻⁵ (3.96 x 10 ⁻⁴)	1.173 x 10 ⁻⁶ (1.038 x 10 ⁻⁶)
1:1 Reduction Parallel Belt Drive (86 mm)	7.514 x 10 ⁻⁵ (6.65 x 10 ⁻⁴)	1.173 x 10 ⁻⁶ (1.038 x 10 ⁻⁶)
1:1 Reduction Parallel Belt Drive (96 mm)	8.704 x 10 ⁻⁵ (7.70 x 10 ⁻⁴)	1.173 x 10 ⁻⁶ (1.038 x 10 ⁻⁶)
2:1 Reduction Parallel Belt Drive (96 mm)	7.129 x 10 ⁻⁵ (6.31 x 10 ⁻⁴)	2.931 x 10 ⁻⁷ (2.595 x 10 ⁻⁶)
Parallel Drive Inertias (Smooth Motor Shaft Option)		
	5 mm Lead	Add per 25 mm, 5 mm Lead
1:1 Reduction Parallel Belt Drive (66 mm)	6.015 x 10 ⁻⁵ (5.32 x 10 ⁻⁴)	1.022 x 10 ⁻⁶ (9.045 x 10 ⁻⁶)
1:1 Reduction Parallel Belt Drive (86 mm)	1.103 x 10 ⁻⁴ (9.76 x 10 ⁻⁴)	1.022 x 10 ⁻⁶ (9.045 x 10 ⁻⁶)
1:1 Reduction Parallel Belt Drive (96 mm)	2.176 x 10 ⁻⁴ (1.93 x 10 ⁻³)	1.022 x 10 ⁻⁶ (9.045 x 10 ⁻⁶)
2:1 Reduction Parallel Belt Drive (96 mm)	8.768 x 10 ⁻⁵ (7.76 x 10 ⁻⁴)	2.555 x 10 ⁻⁷ (2.261 x 10 ⁻⁶)
	10 mm Lead	Add per 25 mm, 10 mm Lead
1:1 Reduction Parallel Belt Drive (66 mm)	6.150 x 10 ⁻⁵ (5.44 x 10 ⁻⁴)	1.173 x 10 ⁻⁶ (1.038 x 10 ⁻⁶)
1:1 Reduction Parallel Belt Drive (86 mm)	1.117 x 10 ⁻⁴ (9.88 x 10 ⁻⁴)	1.173 x 10 ⁻⁶ (1.038 x 10 ⁻⁶)
1:1 Reduction Parallel Belt Drive (96 mm)	2.190 x 10 ⁻⁴ (1.94 x 10 ⁻³)	1.173 x 10 ⁻⁶ (1.038 x 10 ⁻⁶)
2:1 Reduction Parallel Belt Drive (96 mm)	8.802 x 10 ⁻⁵ (7.79 x 10 ⁻⁴)	2.931 x 10 ⁻⁷ (2.595 x 10 ⁻⁶)

*See definitions on page 123

KX75

Models	KX		
		05	10
Screw Lead	in	0.1969	0.3937
	mm	5	10
Maximum Force ³	lbf	2500	1250
	kN	11.1	5.6
Life at Maximum Force ¹	in x 10 ⁶	2.4	22.6
	km	60.7	573.3
C _a (Dynamic Load Rating)	lbf	5746	4820
	kN	25.6	21.4
Maximum Input Torque ²	lbf-in	98	98
	Nm	11	11
Max Rated RPM @ Input Shaft	RPM	4000	4000
Maximum Linear Speed @ Maximum Rated RPM	in/sec	13.1	26.2
	mm/sec	333	666

1. See page 169 for life calculation information.

2. Input torque should be limited such that Max Force is not exceeded. For a parallel belt ratio, the input torque ratings must be divided by the belt ratio for allowable motor torque. The output force ratings remain the same.

3. Maximum allowable actuator-generated force that can be applied routinely. Exceeding this force may result in permanent damage to the actuator. For maximum allowable externally-applied axial forces, consult factory. For high force, short stroke applications, consult factory.

Weights kg (lbs)

Base Actuator Weight (Zero Stroke)	lb	6.75
	kg	3.06
Actuator Weight Adder (Per mm of Stroke)	lb	0.0235
	kg	0.0107
Adder for Inline (excluding motor)		1.12 (2.46)
Adder for Parallel Drive (excluding motor)		1.84 (4.06)
Adder for Front Flange		0.87 (1.91)
Adder for Rear Clevis		0.84 (1.85)
Adder for Two Trunnions		0.71 (1.56)

KX75 Inertias kg-m² (lbf-in-sec²)

	5 mm Lead	Add per 25 mm, 5 mm Lead
Base Unit - Input Drive Shaft Only	9.26 x 10 ⁻⁵ (8.20 x 10 ⁻⁴)	3.13 x 10 ⁻⁶ (2.77 x 10 ⁻⁵)
Inline Unit - w/Motor Coupling	1.25 x 10 ⁻⁴ (1.11 x 10 ⁻³)	3.13 x 10 ⁻⁶ (2.77 x 10 ⁻⁵)
	10 mm Lead	Add per 25 mm, 10 mm Lead
Base Unit - Input Drive Shaft Only	9.48 x 10 ⁻⁵ (8.39 x 10 ⁻⁴)	3.32 x 10 ⁻⁶ (2.94 x 10 ⁻⁵)
Inline Unit - w/Motor Coupling	1.44 x 10 ⁻⁴ (1.28 x 10 ⁻³)	3.32 x 10 ⁻⁶ (2.94 x 10 ⁻⁵)
Parallel Drive Inertias (P10 Option)		
	5 mm Lead	Add per 25 mm, 5 mm Lead
1:1 Reduction Parallel Belt Drive (86 mm)	2.29 x 10 ⁻⁴ (2.03 x 10 ⁻³)	3.13 x 10 ⁻⁶ (2.77 x 10 ⁻⁵)
1:1 Reduction Parallel Belt Drive (96 mm)	3.19 x 10 ⁻⁴ (2.82 x 10 ⁻³)	3.13 x 10 ⁻⁶ (2.77 x 10 ⁻⁵)
1:1 Reduction Parallel Belt Drive (130 mm)	5.96 x 10 ⁻⁴ (5.28 x 10 ⁻³)	3.13 x 10 ⁻⁶ (2.77 x 10 ⁻⁵)
2:1 Reduction Parallel Belt Drive (130 mm)	2.82 x 10 ⁻⁴ (2.50 x 10 ⁻³)	7.83 x 10 ⁻⁷ (6.93 x 10 ⁻⁶)
	10 mm Lead	Add per 25 mm, 10 mm Lead
1:1 Reduction Parallel Belt Drive (86 mm)	2.31 x 10 ⁻⁴ (2.05 x 10 ⁻³)	3.32 x 10 ⁻⁶ (2.94 x 10 ⁻⁵)
1:1 Reduction Parallel Belt Drive (96 mm)	3.21 x 10 ⁻⁴ (2.84 x 10 ⁻³)	3.32 x 10 ⁻⁶ (2.94 x 10 ⁻⁵)
1:1 Reduction Parallel Belt Drive (130 mm)	5.98 x 10 ⁻⁴ (5.30 x 10 ⁻³)	3.32 x 10 ⁻⁶ (2.94 x 10 ⁻⁵)
2:1 Reduction Parallel Belt Drive (130 mm)	2.83 x 10 ⁻⁴ (2.51 x 10 ⁻³)	8.30 x 10 ⁻⁷ (7.36 x 10 ⁻⁶)
Parallel Drive Inertias (Smooth Motor Shaft Option)		
	5 mm Lead	Add per 25 mm, 5 mm Lead
1:1 Reduction Parallel Belt Drive (86 mm)	2.84 x 10 ⁻⁴ (2.51 x 10 ⁻³)	3.13 x 10 ⁻⁶ (2.77 x 10 ⁻⁵)
1:1 Reduction Parallel Belt Drive (96 mm)	4.25 x 10 ⁻⁴ (3.76 x 10 ⁻³)	3.13 x 10 ⁻⁶ (2.77 x 10 ⁻⁵)
1:1 Reduction Parallel Belt Drive (130 mm)	7.33 x 10 ⁻⁴ (6.48 x 10 ⁻³)	3.13 x 10 ⁻⁶ (2.77 x 10 ⁻⁵)
2:1 Reduction Parallel Belt Drive (130 mm)	3.32 x 10 ⁻⁴ (2.94 x 10 ⁻³)	7.83 x 10 ⁻⁷ (6.93 x 10 ⁻⁶)
	10 mm Lead	Add per 25 mm, 10 mm Lead
1:1 Reduction Parallel Belt Drive (86 mm)	2.86 x 10 ⁻⁴ (2.53 x 10 ⁻³)	3.32 x 10 ⁻⁶ (2.94 x 10 ⁻⁵)
1:1 Reduction Parallel Belt Drive (96 mm)	4.27 x 10 ⁻⁴ (3.78 x 10 ⁻³)	3.32 x 10 ⁻⁶ (2.94 x 10 ⁻⁵)
1:1 Reduction Parallel Belt Drive (130 mm)	7.35 x 10 ⁻⁴ (6.50 x 10 ⁻³)	3.32 x 10 ⁻⁶ (2.94 x 10 ⁻⁵)
2:1 Reduction Parallel Belt Drive (130 mm)	3.33 x 10 ⁻⁴ (2.94 x 10 ⁻³)	8.30 x 10 ⁻⁷ (7.35 x 10 ⁻⁶)

*See definitions on page 123

KX Series Linear Actuators

KX90

Models	KX		
		05	10
Screw Lead	in	0.1969	0.3937
	mm	5	10
Maximum Force ³	lbf	3500	1750
	kN	15.6	7.8
Life at Maximum Force ¹	in x 10 ⁶	7.1	90.4
	km	179.6	2295
C _a (Dynamic Load Rating)	lbf	11548	10715
	kN	51.4	47.7
Maximum Input Torque ²	lbf-in	137	137
	Nm	16	16
Max Rated RPM @ Input Shaft	RPM	3000	3000
Maximum Linear Speed @ Maximum Rated RPM	in/sec	9.8	19.7
	mm/sec	250	500

1. See page 169 for life calculation information.

2. Input torque should be limited such that Max Force is not exceeded. For a parallel belt ratio, the input torque ratings must be divided by the belt ratio for allowable motor torque. The output force ratings remain the same.

3. Maximum allowable actuator-generated force that can be applied routinely. Exceeding this force may result in permanent damage to the actuator. For maximum allowable externally-applied axial forces, consult factory. For high force, short stroke applications, consult factory.

Weights kg (lbs)

Base Actuator Weight (Zero Stroke)	lb	11.96
	kg	5.42
Actuator Weight Adder (Per mm of Stroke)	lb	0.0366
	kg	0.016
Adder for Inline (excluding motor)	1.51 (3.35)	
Adder for Parallel Drive (excluding motor)	2.62 (5.80)	
Adder for Front Flange	1.54 (3.40)	
Adder for Rear Clevis	1.45 (3.21)	
Adder for Two Trunnions	0.80 (1.768)	

KX90 Inertias kg-m² (lbf-in-sec²)

	5 mm Lead	Add per 25 mm, 5 mm Lead
Base Unit - Input Drive Shaft Only	2.97×10^{-4} (2.63×10^{-3})	1.11×10^{-5} (9.80×10^{-5})
Inline Unit - w/Motor Coupling	3.84×10^{-4} (3.40×10^{-3})	1.11×10^{-5} (9.80×10^{-5})
	10 mm Lead	Add per 25 mm, 10 mm Lead
Base Unit - Input Drive Shaft Only	3.00×10^{-4} (2.66×10^{-3})	1.13×10^{-5} (1.00×10^{-4})
Inline Unit - w/Motor Coupling	3.87×10^{-4} (3.43×10^{-3})	1.13×10^{-5} (1.00×10^{-4})
Parallel Drive Inertias (P10 Option)		
	5 mm Lead	Add per 25 mm, 5 mm Lead
1:1 Reduction Parallel Belt Drive (96 mm)	5.12×10^{-4} (4.53×10^{-3})	1.11×10^{-5} (9.80×10^{-5})
1:1 Reduction Parallel Belt Drive (130 mm)	7.98×10^{-4} (7.07×10^{-3})	1.11×10^{-5} (9.80×10^{-5})
2:1 Reduction Parallel Belt Drive (130 mm)	3.41×10^{-4} (3.02×10^{-3})	2.77×10^{-6} (2.45×10^{-5})
	10 mm Lead	Add per 25 mm, 10 mm Lead
1:1 Reduction Parallel Belt Drive (96 mm)	5.15×10^{-4} (4.56×10^{-3})	1.13×10^{-5} (1.00×10^{-4})
1:1 Reduction Parallel Belt Drive (130 mm)	8.02×10^{-4} (7.10×10^{-3})	1.13×10^{-5} (1.00×10^{-4})
2:1 Reduction Parallel Belt Drive (130 mm)	3.42×10^{-4} (3.03×10^{-3})	2.82×10^{-6} (2.50×10^{-5})
Parallel Drive Inertias (Smooth Motor Shaft Option)		
	5 mm Lead	Add per 25 mm, 5 mm Lead
1:1 Reduction Parallel Belt Drive (96 mm)	6.18×10^{-4} (5.47×10^{-3})	1.11×10^{-5} (9.80×10^{-5})
1:1 Reduction Parallel Belt Drive (130 mm)	9.35×10^{-4} (8.27×10^{-3})	1.11×10^{-5} (9.80×10^{-5})
2:1 Reduction Parallel Belt Drive (130 mm)	3.91×10^{-4} (3.46×10^{-3})	2.77×10^{-6} (2.45×10^{-5})
	10 mm Lead	Add per 25 mm, 10 mm Lead
1:1 Reduction Parallel Belt Drive (96 mm)	6.21×10^{-4} (5.50×10^{-3})	1.13×10^{-5} (1.00×10^{-4})
1:1 Reduction Parallel Belt Drive (130 mm)	9.38×10^{-4} (8.30×10^{-3})	1.13×10^{-5} (1.00×10^{-4})
2:1 Reduction Parallel Belt Drive (130 mm)	3.92×10^{-4} (3.47×10^{-3})	2.82×10^{-6} (2.50×10^{-5})

*See definitions on page 123

Estimated Service Life

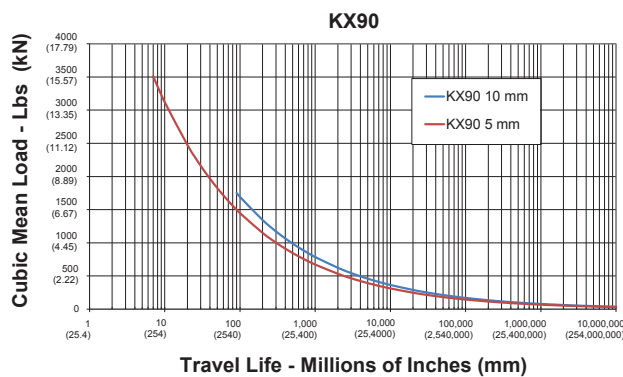
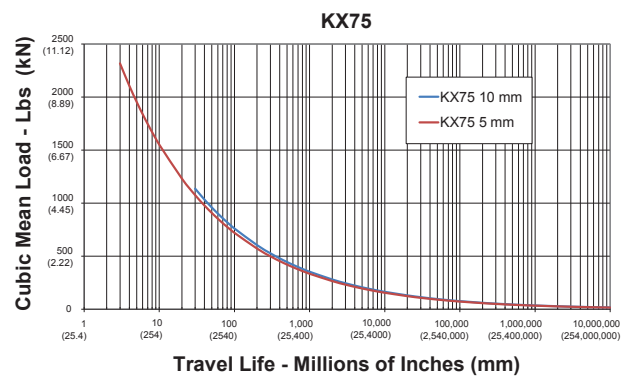
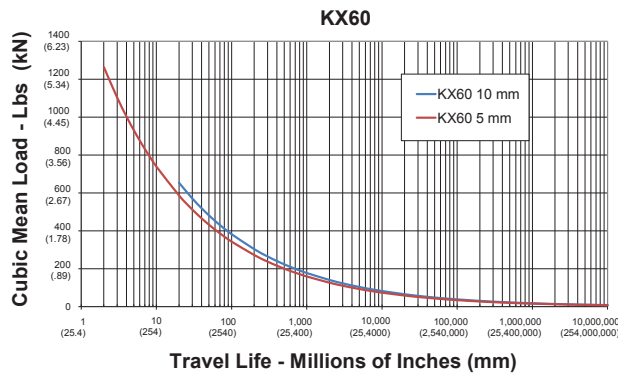

Service Life Estimate Assumptions:

- Sufficient quality and quantity of lubrication is maintained throughout service life (please refer to engineering reference on page 169 for lubrication interval estimates.)
- Bearing and screw temperature between 20° C and 40° C
- No mechanical hard stops (external or internal) or impact loads
- No external side loads
- Does not apply to short stroke, high frequency applications such as fatigue testing or short stroke, high force applications such as pressing. (For information on calculating estimating life for unique applications please refer to the engineering reference on page 169.

The L_{10} expected life of a roller screw linear actuator is expressed as the linear travel distance that 90% of properly maintained roller screws manufactured are expected to meet or exceed. This is not a guarantee and these charts should be used for estimation purposes only.

The underlying formula that defines this value is:
Travel life in millions of inches, where:

$$L_{10} = \left(\frac{C_a}{F_{cml}} \right)^3 \times \ell$$

C_a = Dynamic load rating (lbf)
 F_{cml} = Cubic mean applied load (lbf)
 ℓ = Roller screw lead (inches)

For additional details on calculating estimated service life, please refer to the Engineering Reference, page 169.

Data Curves

Critical Speed vs Stroke Length:

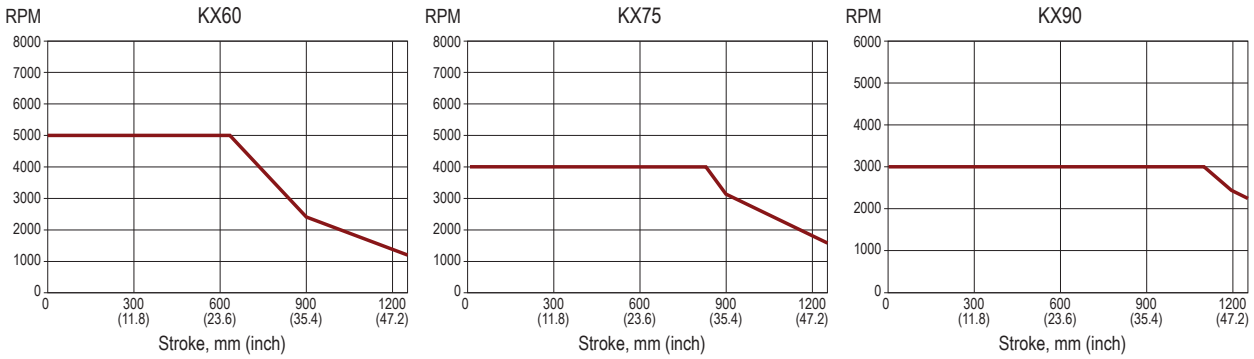

— Actuator Rated Speed
 speed at which we have tested and rated the actuator
 * With longer stroke length actuators, the rated speed of the actuator is determined by the critical speed

Maximum Side Load:

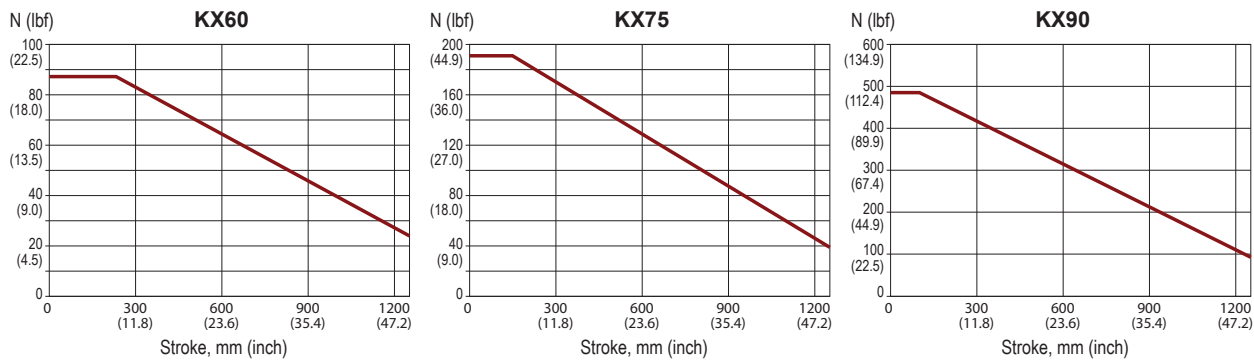

Rated Force vs Stroke:

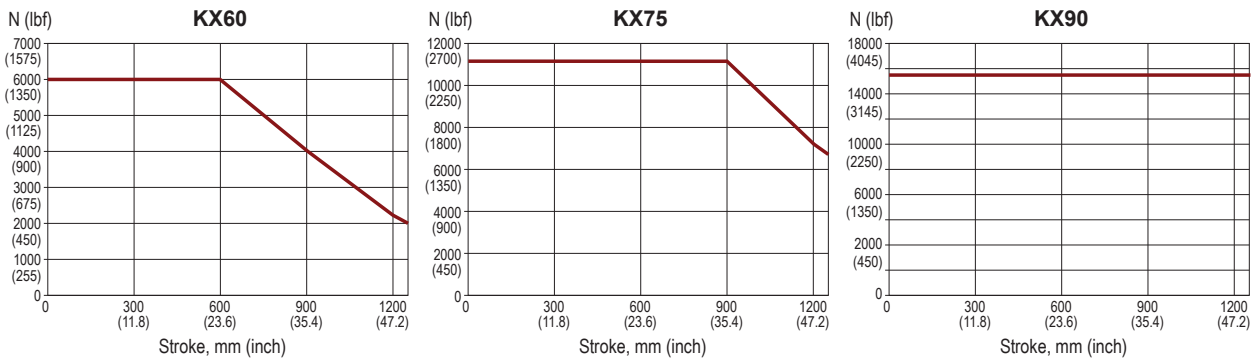

Options

PB = Protective Bellows

This option provides an accordion style protective bellows to protect the main actuator rod from damage due to abrasives or other contaminants in the environment in which the actuator must survive. The standard material of this bellows is S2 Neoprene Coated Nylon, Sewn Construction. This standard bellows is rated for environmental temperatures of -40 to 250 degrees F. Longer strokes may require the main rod of the actuator to be extended beyond standard length. Not available with extended tie rod mounting option. Please contact your local sales representative.

L1 ... L6 = Adjustable External Travel Switches

This option allows up to 3 external switches to be included. These switches provide travel indication to the controller and are adjustable.

KX Series Accessories

KX60	KX75	KX90	
			Mounting Attachments (including proper number of standard T nuts and screws)
KSFF-60	KSFF-75	KSFF-90	Front Flange Attachment
KSST-60	KSST-75	KSST-90	Side Trunnions (includes 2)
KSRC-60	KSRC-75	KSRC-90	Rear Clevis (includes pins)
KSMT-60	KSMT-75	KSMT-90	Metric Side Trunnion
KSMC-60	KSMC-75	KSMC-90	Metric Rear Clevis (includes pins)
			Rod End Attachments
SRM050	SRM075	SRM075	Front Spherical Rod Eye, fits "M" Rod only
REI050	RE075	RE075	Front Rod Eye, fits "M" Rod only
RCI050	RC075	RC075	Front Rod Clevis, fits "M" Rod only
			Clevis Pins
Limit Switches (if required in addition to L1, L2, L3 option in actuator model)			
Option	Quantity	Part Number	Description
L1	1	43403	Normally Open PNP Limit Switch (10-30 VDC, 1m, 3 wire embedded cable)
L2	2	43404	Normally Closed PNP Limit Switch (10-30 VDC, 1m, 3 wire embedded cable)
L3	1	43403	Normally Open PNP Limit Switch (10-30 VDC, 1m, 3 wire embedded cable)
	2	43404	Normally Closed PNP Limit Switch (10-30 VDC, 1m, 3 wire embedded cable)
L4	1	67634	Normally Open NPN Limit Switch (10-30 VDC, 1m, 3 wire embedded cable)
L5	2	67635	Normally Closed NPN Limit Switch (10-30 VDC, 1m, 3 wire embedded cable)
L6	1	67634	Normally Open NPN Limit Switch (10-30 VDC, 1m, 3 wire embedded cable)
	2	67635	Normally Closed NPN Limit Switch (10-30 VDC, 1m, 3 wire embedded cable)

Consult your local sales representative to discuss maximum stroke length allowable with your final configuration.

Dimensions

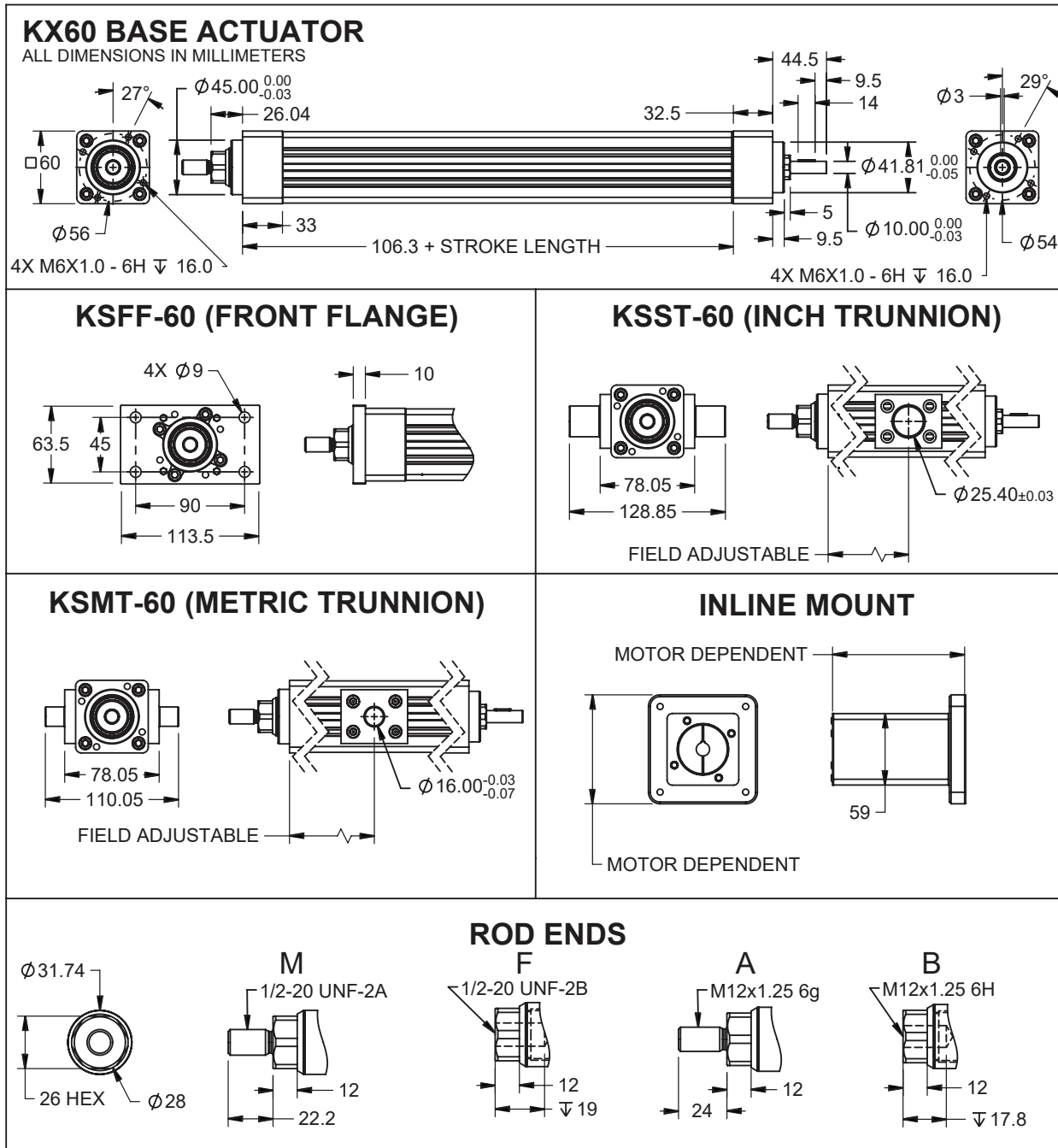

Pre-sale drawings and models are representative and are subject to change. Certified drawings and models are available for a fee. Consult your local Exlar representative for details.

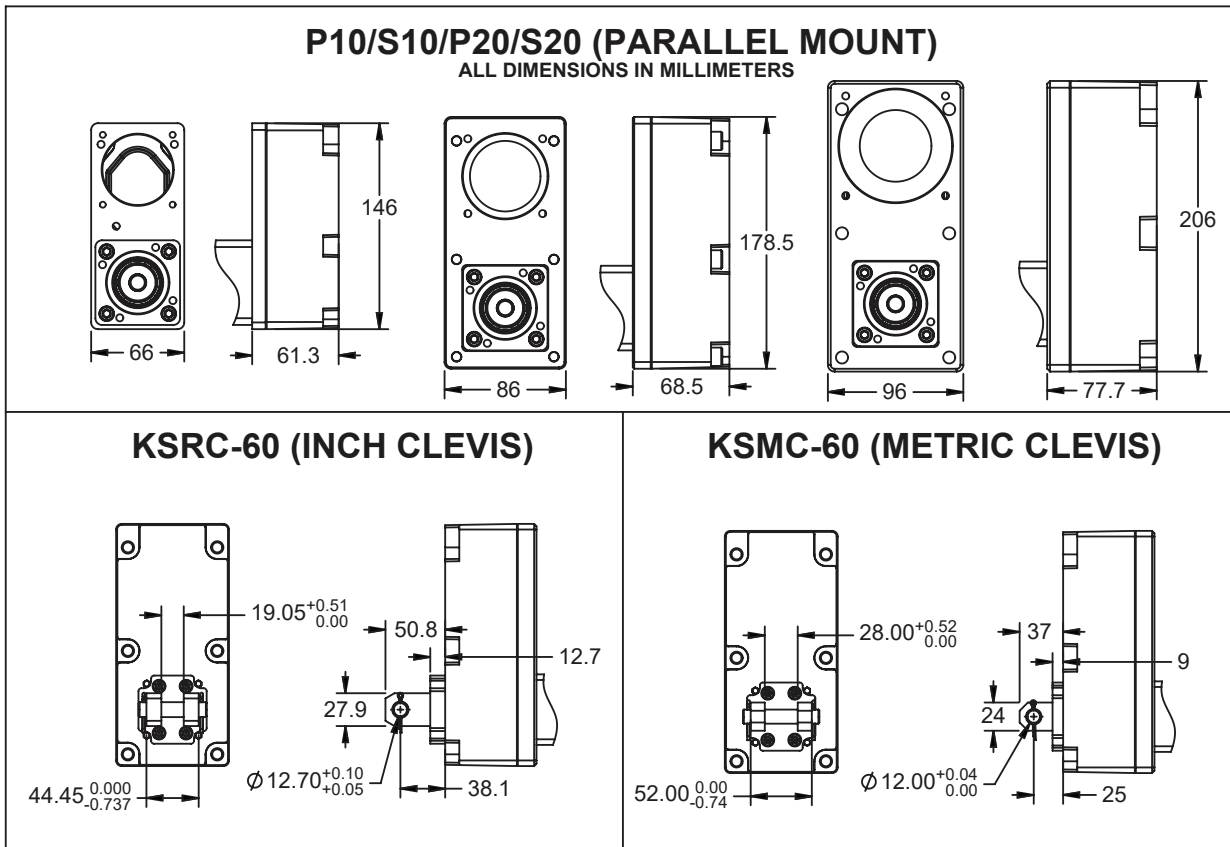

KX Series Linear Actuators

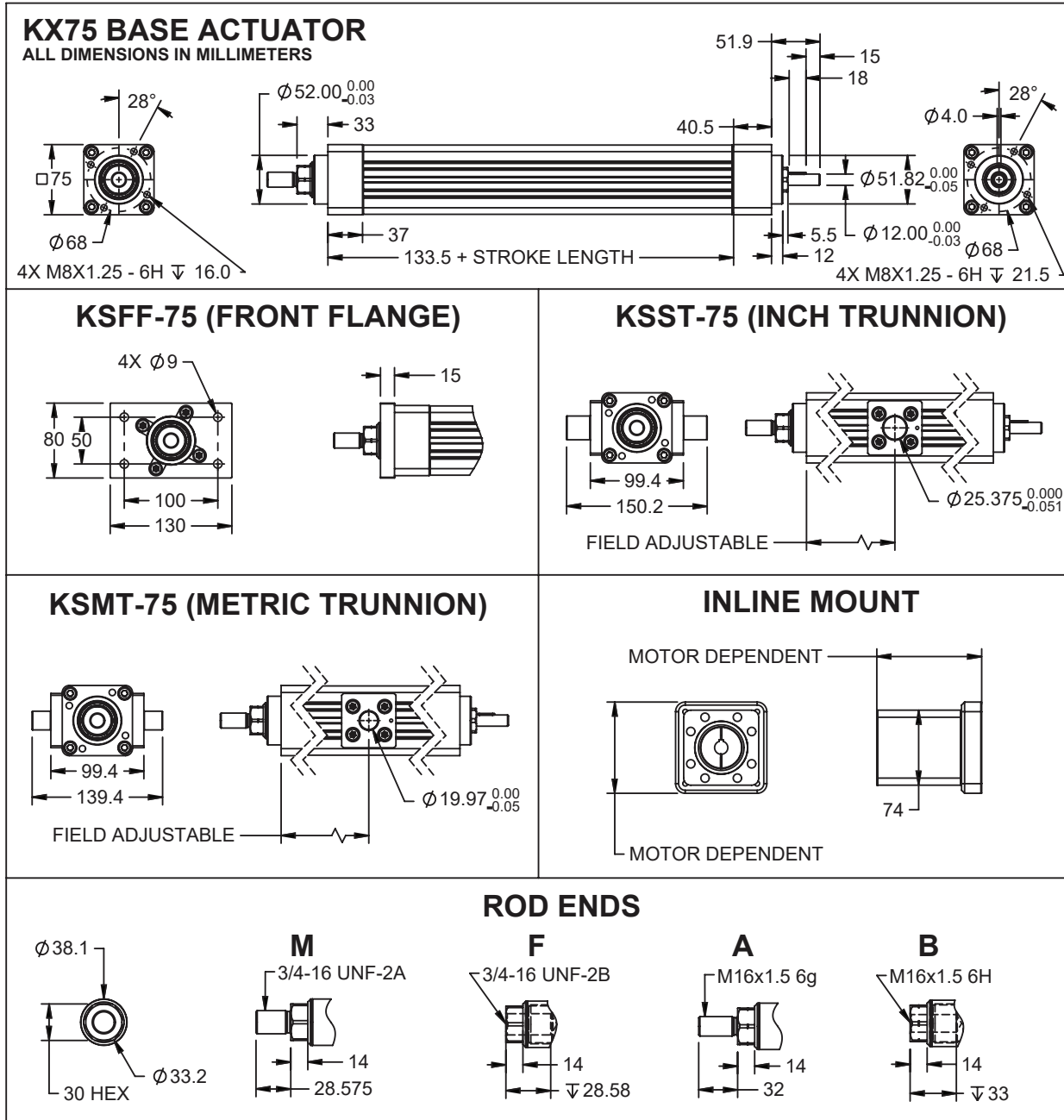

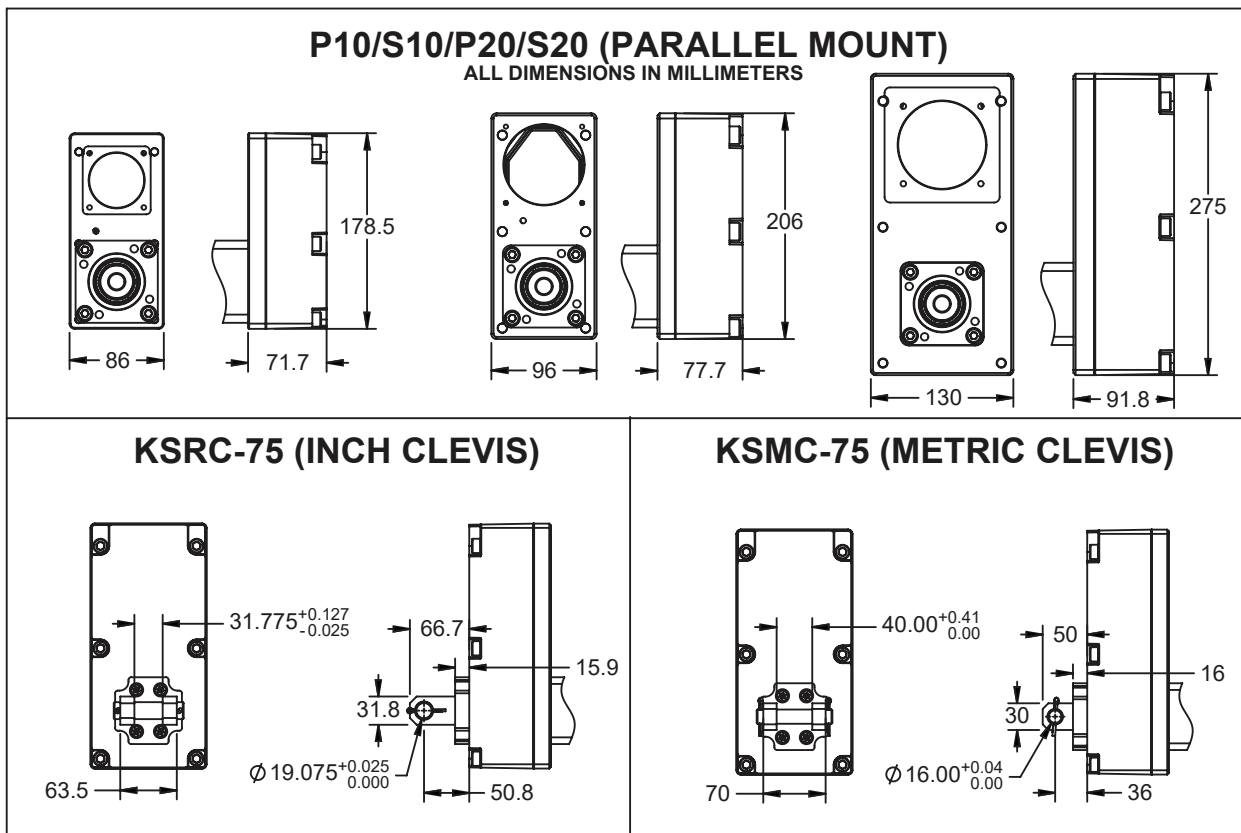

Pre-sale drawings and models are representative and are subject to change. Certified drawings and models are available for a fee. Consult your local Exlar representative for details.

KX Series Linear Actuators

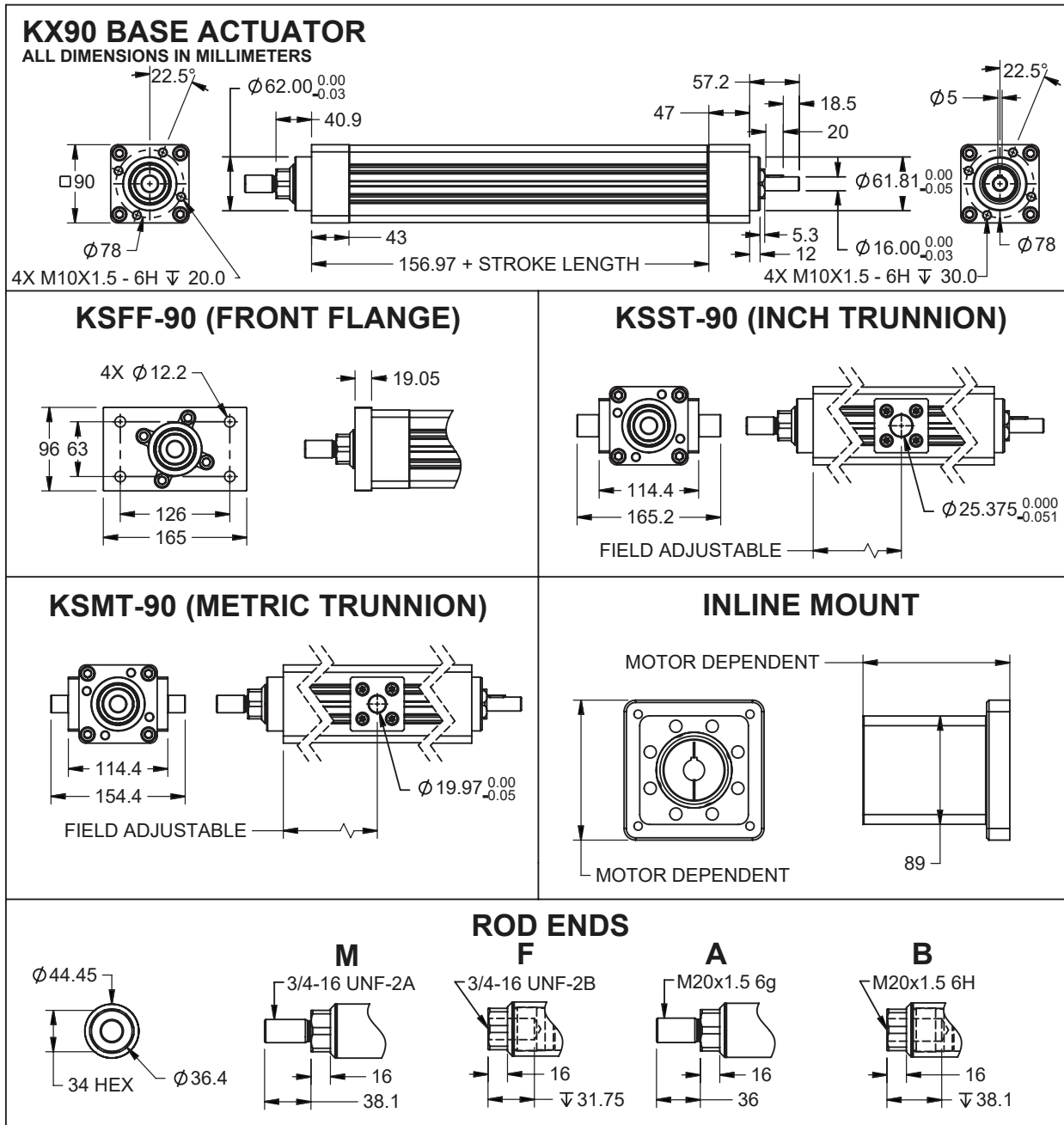

P10/S10/P20/S20 (PARALLEL MOUNT)

ALL DIMENSIONS IN MILLIMETERS

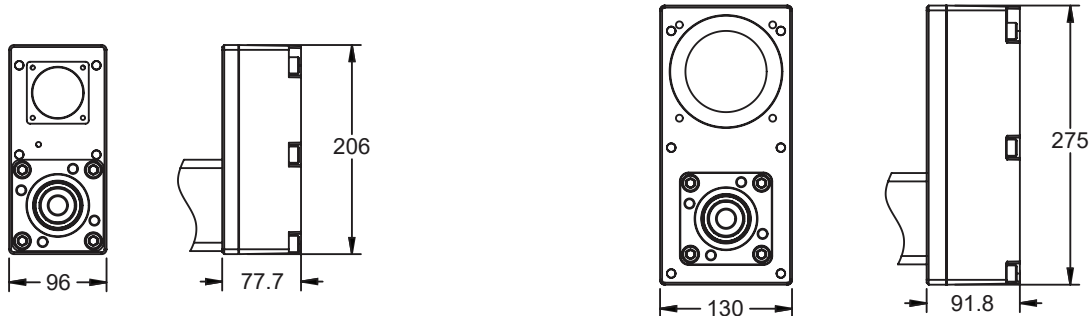

KSRC-90 (INCH CLEVIS)

KSMC-90 (METRIC CLEVIS)

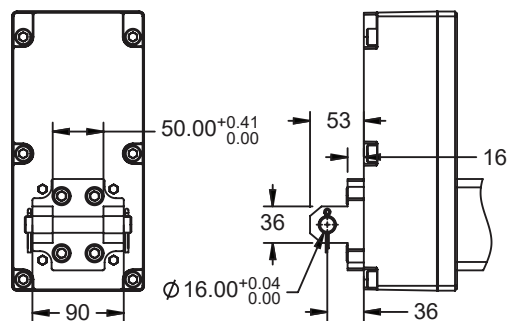
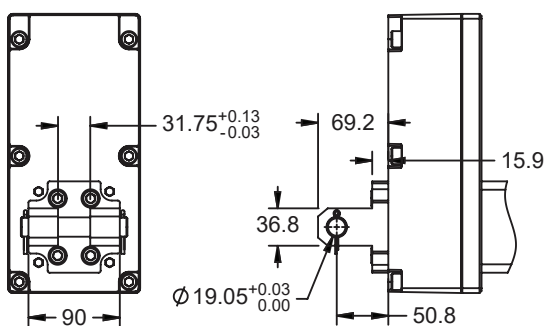

KX Series Linear Actuators

Motor Mount Drawing

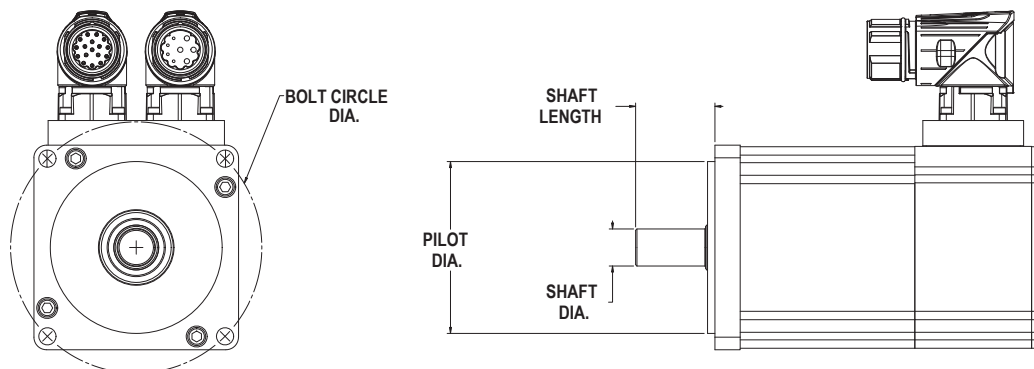

KX60 Motor Mount Codes

Bolt Circle Diameter (mm)	Pilot Diameter (mm)	Shaft Diameter (mm)	Shaft Length (mm)	Key Width (mm)	Motor Mount Code
63	45	14	38	5	GEB
63	50a	12	36	4	GEA
68	60	12	30	4	GFB
68	60	16	48	5	GFA
70	50	14	30	5	JGA
70	50	16	30	5	GGB
70	50	16	37	5	GGA
75	60	11	23	4	IHA
75	60	14	30	5	IHB
90	60	19	40	6	JKF
90	70	14	30	5	JKD
90	70	16	35	NA	JKC
90	70	16	40	5	JKG
90	70	19	40	6	JKA
95	50	14	30	5	ILA
95	65	14	30	5	ILB
100	80	10	32	3	IMD
100	80	14	30	5	IMA
100	80	14	40	5	JMC
100	80	16	40	5	IMB
100	80	19	40	6	IMC

KX75 Motor Mount Codes

Bolt Circle Diameter (mm)	Pilot Diameter (mm)	Shaft Diameter (mm)	Shaft Length (mm)	Key Width (mm)	Motor Mount Code
68	60	16	48	5	GFA
70	50	16	40	5	GGA
75	60	16	48	5	GHA
85	70	22	56	6	GIA
90	60	19	40	6	JKF
90	70	16	40	5	JKG
90	70	19	40	6	JKA
100	80	14	40	5	JMC
100	80	16	40	5	IMB
100	80	19	40	6	IMC
100	80	19	55	6	JMD
100	80	22	48	6	GMA
115	95	19	40	6	INA
115	95	19	55	6	JNC
115	95	22	45	8	JND
115	95	22	70	NA	JNB
115	95	24	45	8	JNA
115	95	24	50	8	INB
130	95	19	40	6	IPC
130	95	24	50	8	IPD
130	110	19	40	6	IPA
130	110	24	50	8	IPB
145	110	19	40	6	JQJ
145	110	19	55	5	JQG
145	110	19	55	6	JQK
145	110	22	55	8	JQH
145	110	22	55	6	JQF
145	110	22	70	8	JQE

KX90 Motor Mount Codes

Bolt Circle Diameter (mm)	Pilot Diameter (mm)	Shaft Diameter (mm)	Shaft Length (mm)	Key Width (mm)	Motor Mount Code
70	50	16	40	5	GGA
75	60	16	48	5	GHA
85	70	22	56	6	GIA
90	60	19	40	6	JKF
90	70	16	40	5	JKG
90	70	19	40	6	JKA
100	80	14	40	5	JMC
100	80	16	40	5	IMB
100	80	19	40	6	IMC
100	80	19	55	6	JMD
100	80	20	40	6	GMB
100	80	22	48	6	GMA
115	95	19	40	6	INA
115	95	19	55	6	JNC
115	95	22	45	8	JND
115	95	22	70	NA	JNB
115	95	24	45	8	JNA
115	95	24	50	8	INB
130	95	19	40	6	IPC
130	95	24	50	8	IPD
130	110	19	40	6	IPA
130	110	24	50	8	IPB
145	110	19	40	6	JQJ
145	110	19	55	5	JQG
145	110	19	55	6	JQK
145	110	22	55	8	JQH
145	110	22	55	6	JQF
145	110	22	70	8	JQE
145	110	24	55	8	JQD
145	110	24	65	8	JQC
145	110	28	55	8	JQB
145	110	28	63	8	JQA

[Return to Table of Contents](#)

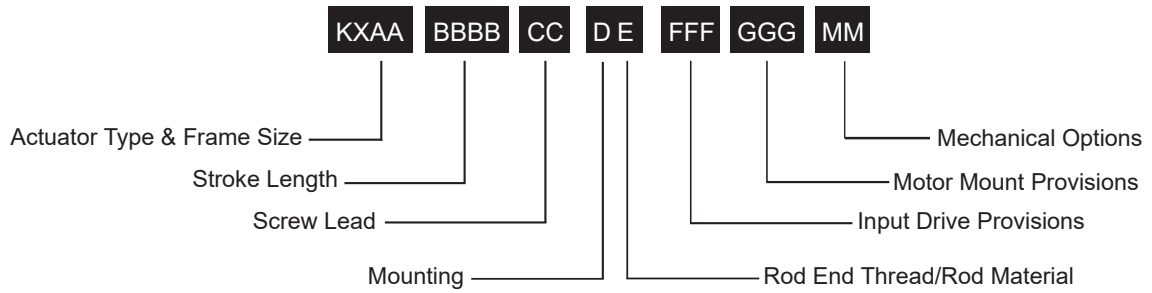

Actuator Series

KX = High Capacity Roller Screw

AA = Actuator Frame Size

60 = 60 mm (2.375 inch)
75 = 75 mm (2.95 inch)
90 = 90 mm (3.54 inch)

BBBB = Stroke Length (mm)

0150 = 150 mm (5.9 inch)
0300 = 300 mm (11.8 inch)
0600 = 600 mm (23.6 inch)
0900 = 900 mm (35.4 inch)

CC = Lead (linear motion per screw revolution)

05 = 5 mm (0.2 inch)
10 = 10 mm (0.4 inch)

D = Mounting Options

N = None, Base Unit
C = Rear Clevis
F = Front Flange
G = Metric Rear Clevis
T = Side Trunnion
Q = Metric Side Trunnion

E = Rod Options

M = Male, US Standard thread
A = Male Metric thread
F = Female US Standard thread
B = Female Metric thread

FFF = Input Drive Provisions

NMT = Drive shaft only, no motor mount
ISC = Inline, includes shaft coupling
Keyed Motor Shaft Options
P10 = Parallel, 1:1 belt reduction
P20 = Parallel, 2:1 belt reduction
Smooth Motor Shaft Options
S10 = Parallel, 1:1 belt reduction
S20 = Parallel, 2:1 belt reduction

GGG = Motor Mount Provisions ¹

See page 135-137 for Motor Mount Code.

MM = Mechanical Options ²

PB = Protective bellows for extending rod

Limit Switches

L1 = One N.O., PNP
L2 = Two N.C., PNP
L3 = One N.O. PNP & two N.C., PNP
L4 = One N.O., NPN
L5 = Two N.C., NPN
L6 = One N.O., NPN & two N.C., NPN

*See Page 129 for Limit Switch details.

NOTES:

1. For oversized motors, contact your local sales representative.
2. For extended temperature operation consult factory for model number.

Please provide a 3D CAD model of motor with all orders to ensure proper mounting compatibility.



For options or specials not listed above or for extended temperature operation, please contact Exlar

[Return to Table of Contents](#)

SLM/SLG SERIES

BRUSHLESS AC SERVO MOTOR / SERVO GEARMOTOR

Compatible with virtually any manufacturer's servo drive

Multiple frame size options

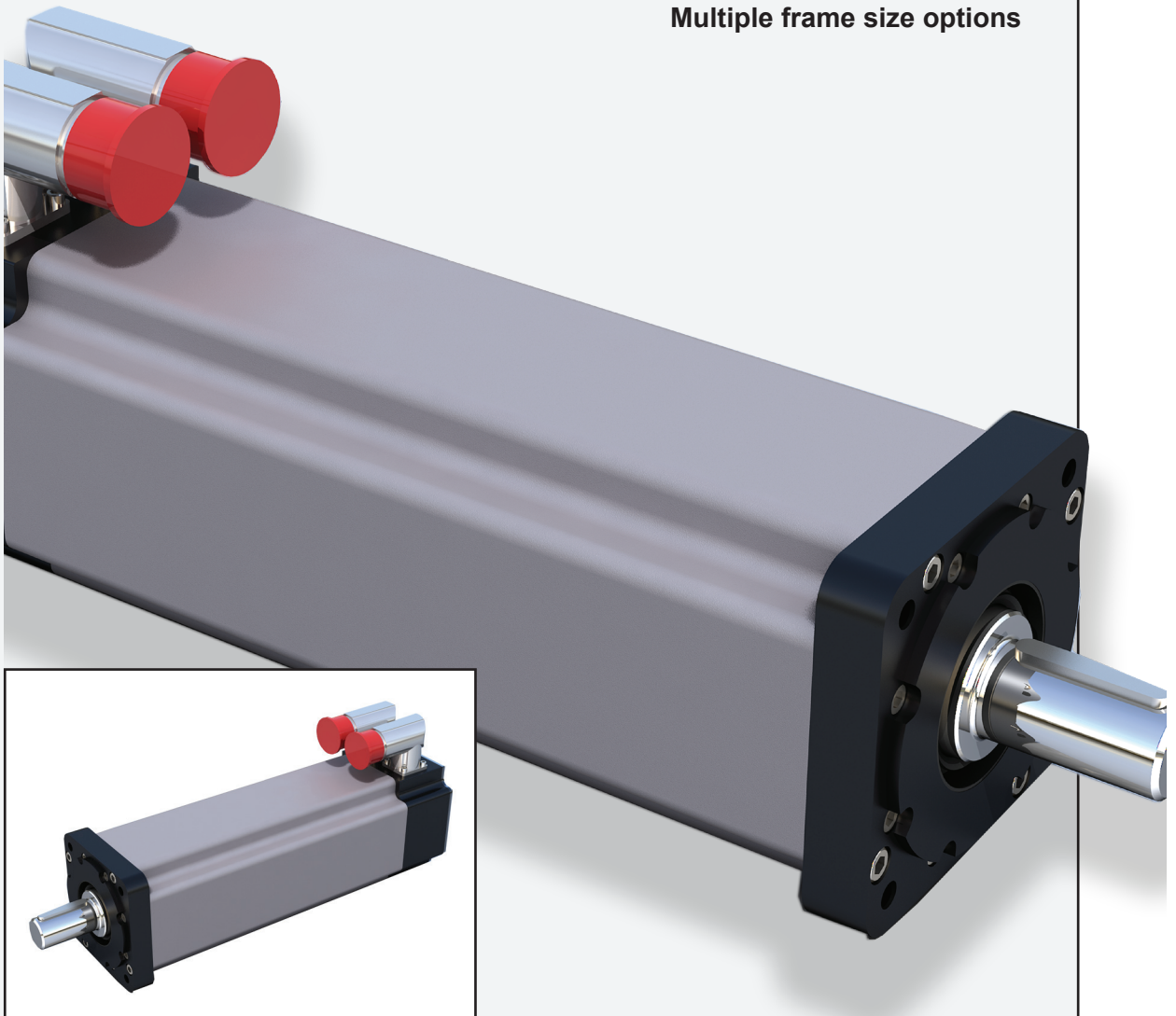

SLM Series Motors and SLG Series Gearmotors

Description

Brushless servo motor and gearmotor technology from Exlar provides one of the highest torque-to-size ratio available in motion control today. Small size, outstanding performance specifications, quality and customization capabilities offer you the right solution for your motion control application.

Unique T-LAM Stator Design Advantage

This innovative design offers several advantages over traditional motor winding for a more efficient and powerful motor.

Built for durability, T-LAM segmented lamination stator technology consists of individual segments, each containing individual phase wiring for maximum motor performance. The robust insulation, high coercive strength magnets, and complete thermal potting provide a more robust motor design, a design yielding a 35 to 70% torque increase in the same package size! T-LAM motor designs have Class 180H insulation systems and UL recognition.

Very High Torque Density

T-LAM technology produces an efficient and powerful motor in a very small package.

- **60 mm SLM060** offers continuous torque up to 15 lbf-in and base speed of 5000 rpm.
- **75 mm SLM075** offers continuous torque up to 36 lbf-in and base speed of 4000 rpm.
- **90 mm SLM090** offers continuous torque up to 56 lbf-in and base speed of 4000 rpm.
- **115 mm SLM115** offers continuous torque up to 176 lbf-in and base speed of 3000 rpm.
- **142 mm SLM142** offers continuous torque up to 237 lbf-in and base speed of 2400 rpm.
- **180 mm SLM180** offers continuous torque up to 612 lbf-in and base speed of 2400 rpm.

Standard Features	
SLM Motor	IP65S sealing
	Right angle rotatable connectors.
	Feedback configurations for nearly all servo amplifiers
	Anodized housings
	Class 180H insulation system
SLG Gearmotor	All features of SLM motor shown above plus...
	High side load bearing design
	Integrated armature and sungear
	Higher stiffness than bolt-on gearhead and motor
	10 arc minute standard backlash, single stage; 13 arc minute standard backlash, dual stage
	Single and double reduction ratios: 4:1, 5:1, 10:1, 16:1, 20:1, 25:1, 40:1, 50:1, and 100:1

SLM Series Motors/SLG Series Gearmotors

Product Features

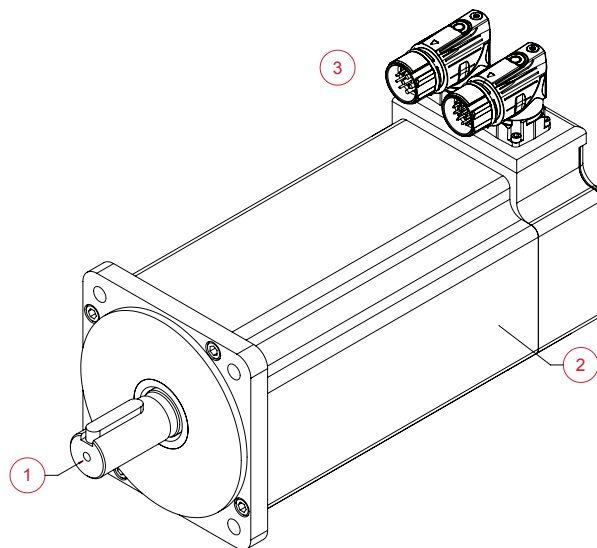
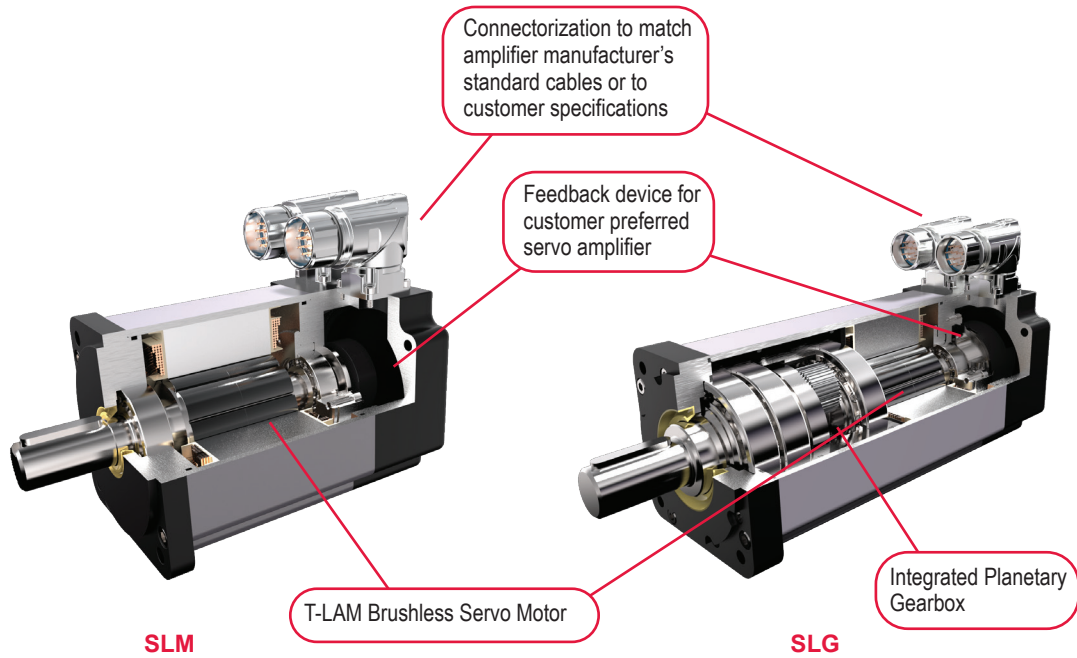

- 1 - Keyed
- 2 - Rear Brake
- 3 - Exlar standard M23 style

Industries and Applications

Automotive

Automotive Assembly

Food Processing

Conveyor Drives

Packaging

Labeling

Machining

Machine tools

Fluid Handling

Winding Machines

Screw Drives

Entertainment / Simulation

Simulation robotics

Animatronics

Medical Equipment

Volumetric pumps

Material Handling

Tensioning

Parts Handling

Web Feed

Stage Positioning

Glass Manufacturing

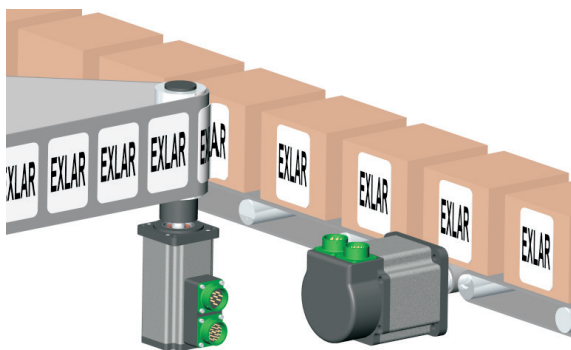

Exlar brushless motors are the highest performance with very compact size. This makes them perfect for high-speed labeling and demanding conveyor drive applications.

Exlar closed-loop, servo-controlled rotary actuators are ideal for operating quarter-turn, full-turn, or multi-turn valves or shaft driven dampers.

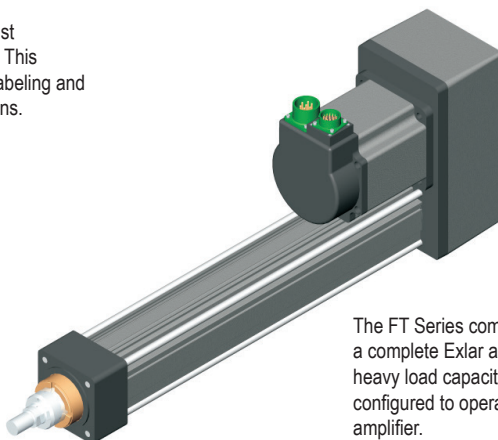
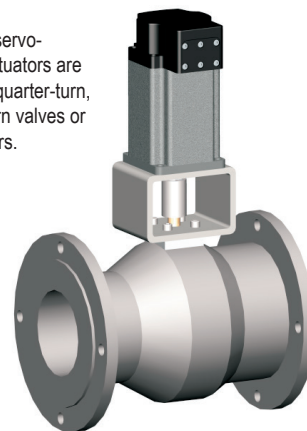

The FT Series combined with SLM/G Series motors provides a complete Exlar actuator solution for applications requiring heavy load capacity and high speeds. The motor can be configured to operate with nearly any manufacturer's servo amplifier.

Electrical and Mechanical Specifications

SLM/SLG060

Motor Stator		118	138	158	168	218	238	258	268	318	338	358	368
Voltage Rating	Vrms	115	230	400	460	115	230	400	460	115	230	400	460
Speed @ Bus Voltage	rpm	5000											
RMS SINUSOIDAL COMMUTATION DATA													
Continuous Motor Torque	lbf-in	7.6	7.3	7.0	7.0	11.9	11.5	11.0	11.3	15.0	15.3	14.6	14.9
	Nm	0.86	0.83	0.79	0.79	1.34	1.30	1.25	1.28	1.70	1.73	1.65	1.69
Peak Motor Torque	lbf-in	15.2	14.7	14.0	14.0	23.8	23.0	22.1	22.6	30.0	30.6	29.2	29.9
	Nm	1.72	1.66	1.58	1.58	2.69	2.60	2.49	2.55	3.39	3.46	3.30	3.38
Torque Constant (Kt) (+/- 10% @ 25°C)	lbf-in/A	2.5	5.2	7.5	9.5	2.5	5.2	8.6	10.1	2.5	5.3	8.8	10.1
	Nm/A	0.28	0.6	0.9	1.1	0.3	0.6	1.0	1.1	0.3	0.6	1.0	1.1
Continuous Current Rating	A	3.4	1.6	1.0	0.8	5.4	2.5	1.4	1.2	6.6	3.2	1.9	1.6
Peak Current Rating	A	6.9	3.1	2.0	1.6	10.8	4.9	2.9	2.5	13.2	6.5	3.7	3.3
O-PK SINUSOIDAL COMMUTATION DATA													
Continuous Motor Torque	lbf-in	7.6	7.3	7.0	7.0	11.9	11.5	11.0	11.3	15.0	15.3	14.6	14.9
	Nm	0.86	0.83	0.79	0.79	1.34	1.30	1.25	1.28	1.70	1.73	1.65	1.69
Peak Motor Torque	lbf-in	15.2	14.7	14.0	14.0	23.8	23.0	22.1	22.6	30.0	30.6	29.2	29.9
	Nm	1.72	1.66	1.58	1.58	2.69	2.60	2.49	2.55	3.39	3.46	3.30	3.38
Torque Constant (Kt) (+/- 10% @ 25°C)	lbf-in/A	1.7	3.7	5.3	6.7	1.7	3.7	6.1	7.2	1.8	3.7	6.2	7.2
	Nm/A	0.20	0.4	0.6	0.8	0.2	0.4	0.7	0.8	0.2	0.4	0.7	0.8
Continuous Current Rating	A	4.9	2.2	1.5	1.2	7.6	3.5	2.0	1.8	9.4	4.6	2.6	2.3
Peak Current Rating	A	9.7	4.5	2.9	2.3	15.2	7.0	4.1	3.5	18.7	9.2	5.3	4.7
MOTOR DATA													
Voltage Constant (Ke) (+/- 10% @ 25°C)	Vrms/Krpm	16.9	35.5	51.5	64.8	16.9	35.5	58.6	69.3	17.3	36.0	59.9	69.3
	Vpk/Krpm	23.9	50.2	72.8	91.7	23.9	50.2	82.9	98.0	24.5	50.9	84.8	98.0
Pole Configuration		8	8	8	8	8	8	8	8	8	8	8	8
Resistance (L-L)(+/- 5% @ 25°C)	Ohms	2.6	12.52	28.82	45.79	1.11	5.26	15.51	20.69	0.76	3.14	9.57	12.22
Inductance (L-L)(+/- 15%)	mH	4.6	21.4	47.9	68.3	2.5	10.2	28.3	39.5	1.7	7.4	18.5	27.4
SLM Armature Inertia (+/- 5%)	bf-in-sec ²	0.000237				0.000413				0.000589			
	Kg-cm ²	0.268				0.466				0.665			
Brake Inertia	bf-in-sec ²	0.00012				0.000120				0.000120			
	Kg-cm ²	0.135				0.135				0.135			
Brake Current @ 24 VDC	A	0.33				0.33				0.33			
Brake Holding Torque	lbf-in	19				19				19			
	Nm	2.2				2.2				2.2			
Brake Engage/Disengage Time	ms	14/28				14/28				14/28			
Mechanical Time Constant (tm)	ms	2.20	2.38	2.60	2.61	1.62	1.74	1.89	1.80	1.50	1.45	1.59	1.52
Electrical Time Constant (te)	ms	1.76	1.71	1.66	1.49	2.24	1.95	1.82	1.91	2.27	2.36	1.93	2.24
Friction Torque	lbf-in (Nm)	0.27 (0.031)				0.34 (0.038)				0.38 (0.043)			
Insulation Class		180 (H)											
Insulation System Volt Rating	Vrms	460											
Environmental Rating		IP65S											

For amplifiers using peak sinusoidal ratings, multiply RMS sinusoidal Kt by 0.707 and current by 1.414.

Gearmotor Data

	1 Stack Motor			2 Stack Motor			3 Stack Motor					
SLG Armature Inertia [*] lbf-in-sec ² (Kg-cm ²)	0.000226 (0.255)			0.000401 (0.453)			0.000576 (0.651)					
GEARING REFLECTED INERTIA	SINGLE REDUCTION						DOUBLE REDUCTION					
	Gear Stages		lbf-in-sec ²	(Kg-cm ²)	Gear Stages		lbf-in-sec ²	(Kg-cm ²)				
	4:1		0.0000132	(0.0149)	16:1		0.0000121	(0.0137)				
	5:1		0.0000087	(0.00984)	20:1, 25:1		0.0000080	(0.00906)				
10:1		0.0000023	(0.00261)	40:1, 50:1, 100:1		0.0000021	(0.00242)					
Backlash at 1% rated torque	10 Arc minutes Efficiency: Single reduction 91%						13 Arc minutes Double Reduction: 86%					

* Add armature inertia to gearing inertia for total SLG system inertia

Test data derived using NEMA recommended aluminum heatsink 10" x 10" x 1/4" at 25°C ambient

SLM Series Motors/SLG Series Gearmotors

SLM/SLG075

Motor Stator		118	138	158	168	218	238	258	268	318	338	358	368
Voltage Rating	Vrms	115	230	400	460	115	230	400	460	115	230	400	460
Speed @ Bus Voltage	rpm	4000											
RMS SINUSOIDAL COMMUTATION													
Continuous Motor Torque	lbf-in	16.6	16.4	16.3	16.0	26.0	26.4	26.2	26.4	37.9	35.9	37.3	36.4
	Nm	1.88	1.85	1.84	1.81	2.94	2.89	2.96	2.98	4.29	4.05	4.21	4.12
Peak Motor Torque	lbf-in	33.3	32.8	32.6	32.1	52.0	52.7	52.4	52.8	75.9	71.7	74.6	72.9
	Nm	3.76	3.70	3.68	3.62	5.88	5.96	5.92	5.96	8.57	8.10	8.43	8.23
Torque Constant (Kt) (+/- 10% @ 25°C)	lbf-in/A	3.4	6.6	12.5	13.1	3.7	6.8	11.6	13.5	3.4	6.8	11.6	13.9
	Nm/A	0.4	0.7	1.4	1.5	0.4	0.8	1.3	1.5	0.4	0.8	1.3	1.6
Continuous Current Rating	A	5.5	2.8	1.5	1.4	7.9	4.4	2.5	2.2	12.5	5.9	3.6	2.9
Peak Current Rating	A	11.0	5.6	2.9	2.7	15.9	8.7	5.1	4.4	25.1	11.8	7.2	5.8
O-PEAK SINUSOIDAL COMMUTATION													
Continuous Motor Torque	lbf-in	16.6	16.4	16.3	16.0	26.0	26.4	26.2	26.4	37.9	35.9	37.3	36.4
	Nm	1.88	1.85	1.84	1.81	2.94	2.98	2.96	2.98	4.29	4.05	4.21	4.12
Peak Motor Torque	lbf-in	33.3	32.8	32.6	32.1	52.0	52.7	52.4	52.8	75.9	71.7	74.6	72.9
	Nm	3.76	3.70	3.68	3.62	5.88	5.96	5.92	5.96	8.57	8.10	8.43	8.23
Torque Constant (Kt) (+/- 10% @ 25°C)	lbf-in/A	2.4	4.6	8.8	9.3	2.6	4.8	8.2	9.6	2.4	4.8	8.2	9.9
	Nm/A	0.3	0.5	1.0	1.0	0.3	0.5	0.9	1.1	0.3	0.5	0.9	1.1
Continuous Current Rating	A	7.8	4.0	2.1	1.9	11.2	6.2	3.6	3.1	17.7	8.4	5.1	4.1
Peak Current Rating	A	15.6	7.9	4.1	3.9	22.4	12.3	7.2	6.2	35.5	16.8	10.1	8.3
MOTOR STATOR DATA													
Voltage Constant (Ke) (+/- 10% @ 25°C)	Vrms/Krpm	23.1	44.7	85.2	89.5	25.0	46.2	78.9	92.4	23.1	46.2	79.4	95.3
	Vpk/Krpm	32.7	63.3	120.4	126.5	35.4	65.3	111.6	130.6	32.7	65.3	112.3	134.7
Pole Configuration		8	8	8	8	8	8	8	8	8	8	8	8
Resistance (L-L)(+/- 5% @ 25°C)	Ohms	1.66	6.42	23.49	26.84	0.83	2.75	8.15	11.01	0.40	1.77	4.83	7.29
Inductance (L-L)(+/- 15%)	mH	4.6	17.3	62.6	69.2	2.6	8.8	25.7	35.2	1.4	5.8	17.0	24.5
SLM Armature Inertia	lbf-in-sec ² (+/- 5%)	0.00054				0.00097				0.00140			
	Kg-cm ²	0.616				1.100				1.583			
Brake Inertia	lbf-in-sec ²	0.000159				0.000159				0.000159			
	Kg-cm ²	0.18				0.18				0.18			
Brake Current @ 25 VDC	A	0.5				0.5				0.5			
Brake Holding Torque	lbf-in	40				40				40			
	Nm	4.5				4.5				4.5			
Brake Engage/Disengage Time	ms	9/35				9/35				9/35			
Mechanical Time Constant (tm)	ms	1.71	1.77	1.79	1.85	1.31	1.27	1.29	1.27	1.05	1.18	1.09	1.14
Electrical Time Constant (te)	ms	2.78	2.69	2.67	2.58	3.11	3.19	3.15	3.20	3.65	3.26	3.53	3.37
Friction Torque	lbf-in (Nm)	0.51 (0.058)				0.67 (0.075)				0.90 (0.101)			
Insulation Class		180 (H)											
Insulation System Volt Rating	Vrms	460											
Environmental Rating		IP65S											

For amplifiers using peak sinusoidal ratings, multiply RMS sinusoidal Kt by 0.707 and current by 1.414.

Gearmotor Data

	1 Stack Motor	2 Stack Motor	3 Stack Motor
SLG Armature Inertia ¹ lbf-in-sec ² (Kg-cm ²)	0.000660 (0.7450)	0.001068 (1.2057)	0.001494 (1.6868)
SLM Armature Inertia ¹ lbf-in-sec ² (Kg-cm ²)	0.000545 (0.6158)	0.000973 (1.0996)	0.001401 (1.5834)
GEARING REFLECTED INERTIA			
	SINGLE REDUCTION		
	Gear Stages	lbf-in-sec ²	(Kg-cm ²)
	4:1	0.0000947	(0.1069)
	5:1	0.0000617	(0.0696)
	10:1	0.0000165	(0.0186)
Backlash at 1% rated torque	10 Arc minutes Efficiency: Single reduction 91%		

¹Add armature inertia to gearing inertia for total SLG system inertia

Test data derived using NEMA recommended aluminum heatsink 10" x 10" x 3/8" at 25°C ambient

SLM Series Motors/SLG Series Gearmotors

SLM/SLG090

Motor Stator		118	138	158	168	218	238	258	268	338	358	368	
Voltage Rating	Vrms	115	230	400	460	115	230	400	460	230	400	460	
Speed @ Bus Voltage	rpm	4000											
RMS SINUSOIDAL COMMUTATION DATA													
Continuous Motor Torque	lbf-in	23.8	24.0	23.7	24.7	39.6	40.0	39.5	39.9	55.7	55.4	55.7	
	Nm	2.68	2.71	2.67	2.79	4.47	4.52	4.46	4.51	6.30	6.26	6.30	
Peak Motor Torque	lbf-in	47.5	48.0	47.3	49.4	79.1	80.0	79.0	79.9	111.5	110.9	111.5	
	Nm	5.37	5.42	5.35	5.58	8.94	9.04	8.93	9.02	12.59	12.52	12.59	
Torque Constant (Kt) (+/- 10% @ 25°C)	lbf-in/A	3.2	6.6	11.6	13.2	3.2	6.6	11.6	13.2	6.6	11.6	13.1	
	Nm/A	0.37	0.7	1.3	1.5	0.4	0.7	1.3	1.5	0.7	1.3	1.5	
Continuous Current Rating	A	8.2	4.0	2.3	2.1	13.6	6.8	3.8	3.4	9.5	5.3	4.8	
Peak Current Rating	A	16.4	8.1	4.6	4.2	27.3	13.5	7.6	6.7	19.0	10.7	9.5	
O-PK SINUSOIDAL COMMUTATION DATA													
Continuous Motor Torque	lbf-in	23.8	24.0	23.7	24.7	39.6	40.0	39.5	39.9	55.7	55.4	55.7	
	Nm	2.68	2.71	2.67	2.79	4.47	4.52	4.46	4.51	6.30	6.26	6.30	
Peak Motor Torque	lbf-in	47.5	48.0	47.3	49.4	79.1	80.0	79.0	79.9	115.5	110.9	111.5	
	Nm	5.37	5.42	5.35	5.58	8.94	9.04	8.93	9.02	12.59	12.52	12.59	
Torque Constant (Kt) (+/- 10% @ 25°C)	lbf-in/A	2.3	4.7	8.2	9.4	2.3	4.7	8.2	9.4	4.6	8.2	9.3	
	Nm/A	0.26	0.5	0.9	1.1	0.3	0.5	0.9	1.1	0.5	0.9	1.0	
Continuous Current Rating	A	11.6	5.7	3.2	2.9	19.3	9.5	5.4	4.8	13.4	7.5	6.7	
Peak Current Rating	A	23.2	11.4	6.5	5.9	38.6	19.1	10.8	9.5	26.9	15.1	13.4	
MOTOR DATA													
Voltage Constant (Ke) (+/- 10% @ 25°C)	Vrms/Krpm	22.1	45.2	78.9	90.4	22.1	45.2	78.9	90.4	44.7	79.4	89.5	
	Vpk/Krpm	31.3	64.0	111.6	127.9	31.3	64.0	111.6	127.9	63.3	112.3	126.5	
Pole Configuration		8	8	8	8	8	8	8	8	8	8	8	
Resistance (L-L)(+/- 5% @ 25°C)	Ohms	0.75	3.06	9.57	11.55	0.30	1.21	3.78	4.86	0.69	2.19	2.75	
Inductance (L-L)(+/- 15%)	mH	6.1	25.6	78.0	88.6	2.9	10.5	37.2	43.1	6.6	24.7	31.4	
SLM Armature Inertia (+/- 5%)	lbf-in-sec ²	0.00054				0.00097				0.00140			
	Kg-cm ²	0.609				1.09				1.58			
Brake Inertia	lbf-in-sec ²	0.00096				0.00096				0.00096			
	Kg-cm ²	1.08				1.08				1.08			
Brake Current @ 24 VDC	A	0.67				0.67				0.67			
Brake Holding Torque	lbf-in (Nm)	97 (11)				97 (11)				97 (11)			
Brake Engage/Disengage Time	ms	20/29				20/29				20/29			
Mechanical Time Constant (tm)	ms	0.83	0.82	0.84	0.77	0.59	0.58	0.59	0.58	0.48	0.49	0.48	
Electrical Time Constant (te)	ms	8.21	7.31	8.14	7.67	9.88	8.66	9.85	8.88	9.57	11.30	11.43	
Friction Torque	lbf-in (Nm)	0.68 (0.077)				0.85 (0.095)				1.06 (0.119)			
Insulation Class		180 (H)											
Insulation System Volt Rating	Vrms	460											
Environmental Rating		IP65S											

For amplifiers using peak sinusoidal ratings, multiply RMS sinusoidal Kt by 0.707 and current by 1.414.

Gearmotor Data

	1 Stack Motor			2 Stack Motor			3 Stack Motor					
SLG Armature Inertia* lbf-in-sec ² (Kg-cm ²)	0.00114 (1.29)			0.00157 (1.77)			0.00200 (2.26)					
GEARING REFLECTED INERTIA	SINGLE REDUCTION						DOUBLE REDUCTION					
	Gear Stages		lbf-in-sec ²		(Kg-cm ²)		Gear Stages		lbf-in-sec ²		(Kg-cm ²)	
	4:1		0.000154		(0.174)		16:1		0.000115		(0.130)	
	5:1		0.000100		(0.113)		20:1, 25:1		0.0000756		(0.0854)	
10:1		0.0000265		(0.0300)		40:1, 50:1, 100:1		0.0000203		(0.0230)		
Backlash at 1% rated torque	10 Arc minutes Efficiency: Single reduction 91%						13 Arc minutes Double Reduction: 86%					

* Add armature inertia to gearing inertia for total SLG system inertia
Test data derived using NEMA recommended aluminum heatsink 10" x 10" x 3/8" at 25°C ambient

SLM Series Motors/SLG Series Gearmotors

SLM/SLG115

Motor Stator		118	138	158	168	238	258	268	338	358	368
Voltage Rating	Vrms	115	230	400	460	230	400	460	230	400	460
Speed @ Bus Voltage	rpm	3000									
RMS SINUSOIDAL COMMUTATION DATA											
Continuous Motor Torque	lbf-in	74.1	74.1	74.3	74.1	123.6	121.4	123.8	172.3	168.9	176.9
	Nm	8.37	8.37	8.39	8.37	13.96	13.72	13.96	19.46	19.09	19.98
Peak Motor Torque	lbf-in	148.2	148.2	148.6	148.1	247.2	242.8	247.2	344.5	337.8	353.7
	Nm	16.74	16.74	16.79	16.74	27.93	27.43	27.93	38.93	38.17	39.96
Torque Constant (Kt) (+/- 10% @ 25°C)	lbf-in/A	4.3	8.7	15.7	17.3	8.7	15.8	17.3	8.5	15.8	17.5
	Nm/A	0.49	1.0	1.8	2.0	1.0	1.8	2.0	1.0	1.8	2.0
Continuous Current Rating	A	19.1	9.5	5.3	4.8	15.9	8.6	8.0	22.7	11.9	11.3
Peak Current Rating	A	38.2	19.1	10.6	9.5	31.8	17.1	15.9	45.4	23.8	22.5
O-PK SINUSOIDAL COMMUTATION DATA											
Continuous Motor Torque	lbf-in	74.1	74.1	74.3	74.1	123.6	121.4	123.6	172.3	168.9	176.9
	Nm	8.37	8.37	8.39	8.37	13.96	13.72	13.96	19.46	19.09	19.98
Peak Motor Torque	lbf-in	148.2	148.2	148.6	148.1	247.2	242.8	247.2	344.5	337.8	353.7
	Nm	16.74	16.74	16.79	16.74	27.93	27.43	27.93	38.93	38.17	39.96
Torque Constant (Kt) (+/- 10% @ 25°C)	lbf-in/A	3.1	6.1	11.1	12.3	6.1	11.2	12.3	6.0	11.2	12.4
	(Nm/A)	0.35	0.7	1.3	1.4	0.7	1.3	1.4	0.7	1.3	1.4
Continuous Current Rating	A	27.0	13.5	7.5	6.7	22.5	12.1	11.3	32.1	16.9	15.9
Peak Current Rating	A	54.0	27.0	15.0	13.5	45.0	24.2	22.5	64.2	33.7	31.9
MOTOR DATA											
Voltage Constant (Ke) (+/- 10% @ 25°C)	Vrms/Krpm	29.6	59.2	106.9	118.5	59.2	108.2	118.5	58.0	108.2	119.8
	Vpk/Krpm	41.9	83.8	151.2	167.6	83.8	153.0	167.6	82.0	153.0	169.4
Pole Configuration		8	8	8	8	8	8	8	8	8	8
Resistance (L-L)(+/- 5% @ 25°C)	Ohms	0.20	0.80	2.60	3.21	0.34	1.17	1.35	0.20	0.72	0.81
Inductance (L-L)(+/- 15%)	mH	3.3	13.0	42.4	52.1	5.9	21.1	25.3	4.0	13.1	17.1
SLM Armature Inertia (+/- 5%)	lbf-in-sec ²	0.00342				0.00620			0.00899		
	Kg-cm ²	3.86				7.00			10.14		
Brake Inertia	lbf-in-sec ²	0.00327				0.00327			0.00327		
	Kg-cm ²	3.70				3.70			3.70		
Brake Current @ 24 VDC	A	0.75				0.75			0.75		
Brake Holding Torque	lbf-in (Nm)	195 (22)				195 (22)			195 (22)		
Brake Engage/Disengage Time	ms	25/50				25/50			25/50		
Mechanical Time Constant (tm)	ms	0.80	0.80	0.79	0.80	0.61	0.63	0.61	0.54	0.56	0.51
Electrical Time Constant (te)	ms	16.26	16.26	16.34	16.25	17.6	18.06	18.72	18.5	18.14	21.16
Friction Torque	lbf-in (Nm)	1.43 (0.16)				1.81 (0.204)			2.32 (0.262)		
Insulation Class		180 (H)									
Insulation System Volt Rating	Vrms	460									
Environmental Rating		IP65S									

For amplifiers using peak sinusoidal ratings, multiply RMS sinusoidal Kt by 0.707 and current by 1.414.

Gearmotor Data

	1 Stack Motor			2 Stack Motor			3 Stack Motor		
SLG Armature Inertia [*] lbf-in-sec ² (Kg-cm ²)	0.00662 (7.47)			0.00945 (10.67)			0.01228 (13.86)		
GEARING REFLECTED INERTIA	SINGLE REDUCTION						DOUBLE REDUCTION		
	Gear Stages	lbf-in-sec ²	(Kg-cm ²)	Gear Stages	lbf-in-sec ²	(Kg-cm ²)			
	4:1	0.000895	(1.010)	16:1	0.000513	(0.579)			
	5:1	0.000585	(0.660)	20:1, 25:1	0.000346	(0.391)			
	10:1	0.000152	(0.172)	40:1, 50:1, 100:1	0.000092	(0.104)			
Backlash at 1% rated torque	10 Arc minutes Efficiency: Single reduction 91%						13 Arc minutes Double Reduction: 86%		

* Add armature inertia to gearing inertia for total SLG system inertia

Test data derived using NEMA recommended aluminum heatsink 12" x 12" x 1/2" at 25°C ambient

SLM Series Motors/SLG Series Gearmotors

SLM142

Motor Stator		118	138	158	168	238	258	268	358	368
Bus Voltage	Vrms	115	230	400	460	230	400	460	400	460
Speed @ Bus Voltage	RPM	2400								
RMS SINUSOIDAL COMMUTATION DATA										
Continuous Motor Torque	lbf-in	108.5	107.2	104.8	109.4	179.9	178.8	177.8	237.2	238.3
	Nm	12.25	(2.12)	11.84	12.36	20.32	20.20	20.09	26.80	26.93
Peak Motor Torque	lbf-in	216.9	214.5	209.5	218.8	359.8	357.6	355.7	474.4	476.7
	Nm	24.51	24.23	23.67	24.72	40.65	40.40	40.19	53.60	53.85
Torque Constant (Kt) (+/- 10% @ 25°C)	lbf-in/A	5.9	11.8	20.2	23.6	11.8	20.2	23.6	20.2	24.0
	Nm/A	0.67	1.3	2.3	2.7	1.3	2.3	2.7	2.3	2.7
Continuous Current Rating	A	20.5	10.2	5.8	5.2	17.0	9.9	8.4	13.1	11.1
Peak Current Rating	A	41.1	20.3	11.6	10.4	34.1	19.8	16.8	26.2	22.2
O-PK SINUSOIDAL COMMUTATION DATA										
Continuous Motor Torque	lbf-in	108.5	107.2	104.8	109.4	179.9	178.8	177.8	237.2	238.3
	Nm	12.25	12.12	11.84	12.36	20.32	20.20	20.09	26.80	26.93
Peak Motor Torque	lbf-in	216.9	214.5	209.5	218.8	359.8	357.6	355.7	474.4	476.7
	Nm	24.51	24.23	23.67	24.72	40.65	40.40	40.19	53.60	53.85
Torque Constant (Kt) (+/- 10% @ 25°C)	lbf-in/A	4.2	8.3	14.3	16.7	8.3	14.3	16.7	14.3	17.0
	Nm/A	0.47	0.9	1.6	1.9	0.9	1.6	1.9	1.6	1.9
Continuous Current Rating	A	29.1	14.4	8.2	7.3	24.1	14.0	11.9	18.5	15.7
Peak Current Rating	A	58.1	28.7	16.4	14.7	48.2	27.9	23.8	37.1	31.4
MOTOR DATA										
Voltage Constant (Ke)	Vrms/Krpm	40.3	80.6	138.1	161.1	80.6	138.1	161.1	138.1	164.0
(+/- 10% @ 25°C)	Vpk/Krpm	57.0	113.9	195.3	227.9	113.9	195.3	227.9	195.3	232.0
Pole Configuration		8	8	8	8	8	8	8	8	8
Resistance (L-L)(+/- 5% @ 25°C)	Ohms	0.21	0.87	2.68	3.34	0.339	1.01	1.39	0.61	0.858
Inductance (L-L)(+/- 15%)	mH	5.4	21.7	63.9	78.3	10.4	27.6	41.5	20.0	28.2
Armature Inertia (+/- 5%)	lb-in-sec ²	0.00927				0.01537			0.02146	
	Kg-cm ²	10.47				17.363			24.249	
Brake Inertia	lb-in-sec ²	0.008408				0.008408			0.008408	
	Kg-cm ²	9.5				9.5			9.5	
Brake Current @ 24 VDC	A	1.0				1.0			1.0	
Brake Holding Torque	lbf-in (Nm)	354 (39.99)				354 (39.99)			354 (39.99)	
Brake Engage/Disengage Time	ms	25/73				25/73			25/73	
Mechanical Time Constant (tm)	ms	1.23	1.26	1.32	1.21	0.81	0.82	0.83	0.70	0.69
Electrical Time Constant (te)	ms	25.59	25.02	23.88	23.43	30.58	27.30	29.89	32.60	32.90
Friction Torque	lbf-in (Nm)	2.07 (0.234)				2.65 (0.299)			3.32 (0.375)	
Insulation Class		180 (H)								
Insulation System Volt Rating	Vrms	460								
Environmental Rating		IP65S								

For amplifiers using peak sinusoidal ratings, multiply RMS sinusoidal Kt by 0.707 and current by 1.414.
Gearmotor not available on 142 frame motor.

Test data derived using NEMA recommended aluminum heatsink 12" x 12" x 1/2" at 25°C ambient

SLM Series Motors/SLG Series Gearmotors

SLM180

Motor Stator		138	158	168	238	258	268	358	368
Bus Voltage	Vrms	230	400	460	230	400	460	400	460
Speed @ Bus Voltage	RPM	2400							
RMS SINUSOIDAL COMMUTATION DATA									
Continuous Motor Torque	lbf-in	254.2	249.9	261.9	424.8	423.0	427.5	595.6	611.6
	Nm	28.72	28.23	29.59	47.99	47.79	48.30	67.29	69.10
Peak Motor Torque	lbf-in	508.4	499.8	523.8	849.6	846.0	855.1	1,191.2	1,223.2
	Nm	57.44	56.47	59.18	95.99	95.59	96.61	134.58	138.19
Torque Constant (Kt) (+/- 10% @ 25°C)	lbf-in/A	12.6	21.8	25.2	12.6	21.8	25.2	21.4	25.2
	Nm/A	1.4	2.5	2.8	1.4	2.5	2.8	2.4	2.8
Continuous Current Rating (IG)	A	22.6	12.8	11.6	37.7	21.7	19.0	31.1	27.2
Peak Current Rating	A	45.2	25.6	23.3	75.5	43.4	38.0	62.2	54.3
O-PK SINUSOIDAL COMMUTATION DATA									
Continuous Motor Torque	lbf-in	254.2	249.9	261.9	424.8	423.0	427.5	595.6	611.6
	Nm	28.72	28.23	29.59	47.99	47.79	48.30	67.29	69.10
Peak Motor Torque	lbf-in	508.4	499.8	523.8	849.6	846.0	855.1	1,191.2	1,223.2
	Nm	57.44	56.47	59.18	95.99	95.59	96.61	134.58	138.19
Torque Constant (Kt) (+/- 10% @ 25°C)	lbf-in/A	8.9	15.4	17.8	8.9	15.4	17.8	15.1	17.8
	Nm/A	1.0	1.7	2.0	1.0	1.7	2.0	1.7	2.0
Continuous Current Rating	A	31.9	18.1	16.4	53.4	30.7	26.8	44.0	38.4
Peak Current Rating	A	63.9	36.2	32.9	106.7	61.3	53.7	88.0	76.8
MOTOR STATOR DATA									
Voltage Constant (Ke) (+/- 10% @ 25°C)	Vrms/Krpm	85.9	148.9	171.8	85.9	148.9	171.8	146.1	171.8
	Vpk/Krpm	121.5	210.6	243.0	121.5	210.6	243.0	206.6	243.0
Pole Configuration		8	8	8	8	8	8	8	8
Resistance (L-L)(+/- 5% @ 25°C)	Ohms	0.325	1.010	1.224	0.134	0.407	0.530	0.233	0.306
Inductance (L-L)(+/- 15%)	mH	8.3	24.8	29.4	3.9	11.8	15.8	7.5	10.3
Armature Inertia (+/- 5%)	lb-in-sec ²	0.05051			0.08599			0.12147	
	Kg-cm ²	57.071			97.159			137.246	
Brake Inertia	lb-in-sec ²	0.02815							
	Kg-cm ²	31.8							
Brake Current @ 24 VDC	A	1.45							
Brake Holding Torque	lbf-in (Nm)	708 (80)							
Brake Engage/Disengage Time	ms	53/97							
Mechanical Time Constant (tm)	ms	2.25	2.33	2.12	1.58	1.59	1.56	1.34	1.27
Electrical Time Constant (te)	ms	25.44	24.58	24.03	29.38	29.14	29.76	32.07	33.81
Friction Torque	lbf-in (Nm)	5.07 (0.573)			7.80 (0.881)			11.52 (1.302)	
Insulation Class		180 (H)							
Insulation System Volt Rating	Vrms	460							
Thermal Switch, Case Temp	deg C	100							
Environmental Rating		IP65S							

For amplifiers using peak sinusoidal ratings, multiply RMS sinusoidal Kt by 0.707 and current by 1.414.
Gearmotor not available on 180 frame.

Test data derived using NEMA recommended aluminum heatsink 16" x 16" x 1" at 25°C ambient

SLM Series Motors/SLG Series Gearmotors

SLG Series Gearmotor General Performance Specifications

Two torque ratings for the SLG Series Gearmotors are given in the table below. The left hand columns give the maximum (peak) allowable output torque for the indicated ratios of each size SLG Series Gearmotor. This is NOT the rated output torque of the motor multiplied by the ratio of the reducer.

It is possible to select a configuration of the motor selection and gear ratio such that the rated motor torque, multiplied by the gear ratio exceeds these ratings. It is the responsibility of the user to ensure that the settings of the system, including the amplifier, do not allow these values to be exceeded.

The right hand columns give the output torque at the indicated speed which will result in 10,000 hour (L10). The setup of the system, including the amplifier, will determine the actual output torque and speed.

SLM Radial Load

RPM	50	100	250	500	1000	3000
SLM060 lbf (N)	250 (1112)	198 (881)	148 (658)	116 (516)	92 (409)	64 (285)
SLM075 lbf (N)	278 (1237)	220 (979)	162 (721)	129 (574)	102 (454)	71 (316)
SLM090 lbf (N)	427 (1899)	340 (1512)	250 (1112)	198 (881)	158 (703)	109 (485)
SLM115 lbf (N)	579 (2576)	460 (2046)	339 (1508)	269 (1197)	214 (952)	148 (658)
SLM142 lbf (N)	1367 (6081)	1085 (4826)	800 (3559)	635 (2825)	504 (2242)	349 (1552)
SLM180 lbf (N)	2237 (9951)	1776 (7900)	1308 (5818)	1038 (4617)	824 (3665)	605 (2691)

SLG Radial Load

RPM	50	100	250	500	1000	3000
SLG060 lbf (N)	189 (841)	150 (667)	110 (489)	88 (391)	70 (311)	48 (214)
SLG075 lbf (N)	343 (1526)	272 (1210)	200 (890)	159 (707)	126 (560)	88 (391)
SLG090 lbf (N)	350 (1557)	278 (1237)	205 (912)	163 (725)	129 (574)	89 (396)
SLG115 lbf (N)	858 (3817)	681 (3029)	502 (2233)	398 (1770)	316 (1406)	218 (970)

Side load ratings shown above are for 10,000 hour bearing life at 25 mm from motor face at given rpm.

Output Torque Ratings—Mechanical

Model	Ratio	Maximum Allowable Output Torque Set by User- lbf-in (Nm)	Output Torque @ Speed for 10,000 Hour Life – lbf-in (Nm)		
			1000 RPM	3000 RPM	5000 RPM
SLG060	4:1	603 (68.1)	144 (16.2)	104 (11.7)	88 (9.9)
	5:1	522 (58.9)	170 (19.2)	125 (14.1)	105 (11.9)
	10:1	327 (36.9)	200 (22.6)	140 (15.8)	120 (13.6)
	16:1	603 (68.1)	224 (25.3)	160 (18.1)	136 (15.4)
	20:1	603 (68.1)	240 (27.1)	170 (19.2)	146 (16.5)
	25:1	522 (58.9)	275 (31.1)	200 (22.6)	180 (20.3)
	40:1	603 (68.1)	288 (32.5)	208 (23.5)	180 (20.3)
	50:1	522 (58.9)	340 (38.4)	245 (27.7)	210 (23.7)
	100:1	327 (36.9)	320 (36.1)	280 (31.6)	240 (27.1)
			1000 RPM	2500 RPM	4000 RPM
SLG075	4:1	1618 (182.3)	384 (43.4)	292 (32.9)	254 (23.7)
	5:1	1446 (163.4)	395 (44.6)	300 (33.9)	260 (29.4)
	10:1	700 (79.1)	449 (50.7)	341 (38.5)	296 (33.4)
			1000 RPM	2500 RPM	4000 RPM
SLG090	4:1	2078 (234.8)	698 (78.9)	530 (59.9)	460 (51.9)
	5:1	1798 (203.1)	896 (101.2)	680 (76.8)	591 (66.8)
	10:1	1126 (127.2)	1043 (117.8)	792 (89.5)	688 (77.7)
	16:1	2078 (234.8)	1057 (119.4)	803 (90.7)	698 (78.9)
	20:1	2078 (234.8)	1131 (127.8)	859 (97.1)	746 (84.3)
	25:1	1798 (203.1)	1452 (164.1)	1103 (124.6)	958 (108.2)
	40:1	2078 (234.8)	1392 (157.3)	1057 (119.4)	918 (103.7)
	50:1	1798 (203.1)	1787 (201.9)	1358 (153.4)	1179 (133.2)
	100:1	1126 (127.2)	1100 (124.3)	1100 (124.3)	1100 (124.3)
			1000 RPM	2000 RPM	3000 RPM
SLG115	4:1	4696(530.4)	1392 (157.3)	1132 (127.9)	1000 (112.9)
	5:1	4066 (459.4)	1445 (163.3)	1175 (132.8)	1040 (117.5)
	10:1	2545 (287.5)	1660 (187.6)	1350 (152.6)	1200 (135.6)
	16:1	4696 (530.4)	2112 (238.6)	1714 (193.0)	1518 (171.0)
	20:1	4696 (530.4)	2240 (253.1)	1840 (207.9)	1620 (183.0)
	25:1	4066 (459.4)	2350 (265.5)	1900 (214.7)	1675 (189.2)
	40:1	4696 (530.4)	2800 (316.4)	2240 (253.1)	2000 (225.9)
	50:1	4066 (459.4)	2900 (327.7)	2350 (265.5)	2100 (237.3)
	100:1	2545 (287.5)	2500 (282.5)	2500 (282.5)	2400 (271.2)

1 Stage 2 Stage

Motor and Gearmotor Weight

	SLM/G060			SLM/G075		SLM/G090			SLM/G115			SLM142	SLM180
	Motor	1 Stage	2 Stage	Motor	1 Stage	Motor	1 Stage	2 Stage	Motor	1 Stage	2 Stage	(gear stages not available on SLM142 and SLM180)	
1 Stack lbs (kg)	3.0 (1.4)	7.5 (3.4)	9.3 (2.4)	4.2 (1.9)	6.6 (3.0)	5.4 (2.4)	12.8 (5.8)	14.8 (6.7)	14.2 (6.4)	28 (12.7)	34 (15.4)	31 (14.0)	60 (27.2)
2 Stack lbs (kg)	4.1 (1.9)	8.6 (3.9)	10.4 (4.7)	6.0 (2.7)	8.4 (3.8)	7.8 (3.5)	15.2 (6.9)	17.2 (7.8)	22.0 (9.9)	35.8 (16.2)	41.8 (18.9)	39 (17.7)	82 (37.2)
3 Stack lbs (kg)	5.2 (2.4)	9.7 (4.4)	11.5 (5.2)	7.8 (3.5)	10.2 (4.6)	10.2 (4.6)	17.6 (7.9)	19.6 (8.9)	29.8 (13.5)	43.6 (19.8)	49.6 (22.5)	47 (21.3)	104 (47.2)
Brake		1.8 (0.8)			0.8 (0.4)		2.7 (1.2)			4.1 (1.9)		6.0 (2.7)	12 (5.4)

Speed and Torque Curves

These speed vs. torque curves represent approximate continuous torque ratings at the indicated rpms. Different types of servo amplifiers offer varying motor torque.

— Peak Torque
 ■ Continuous Torque

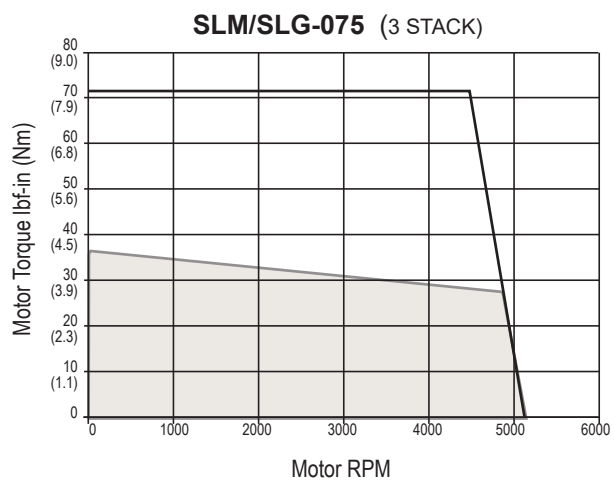
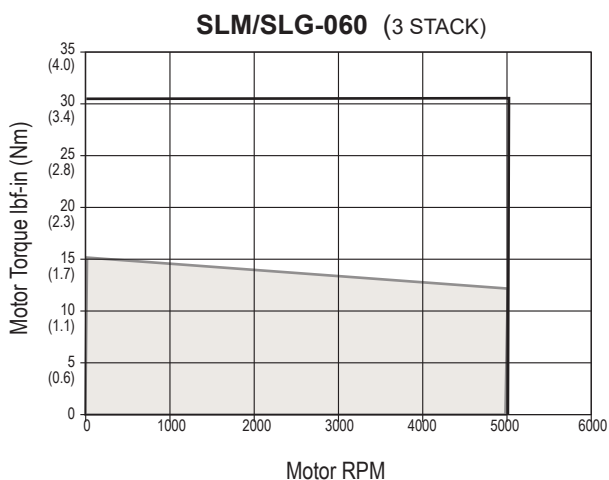
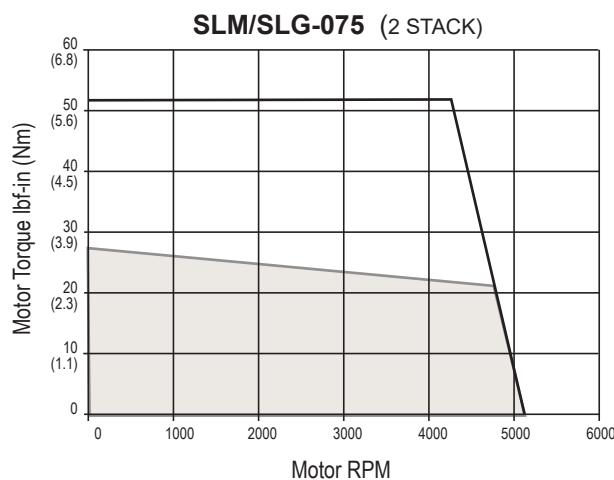
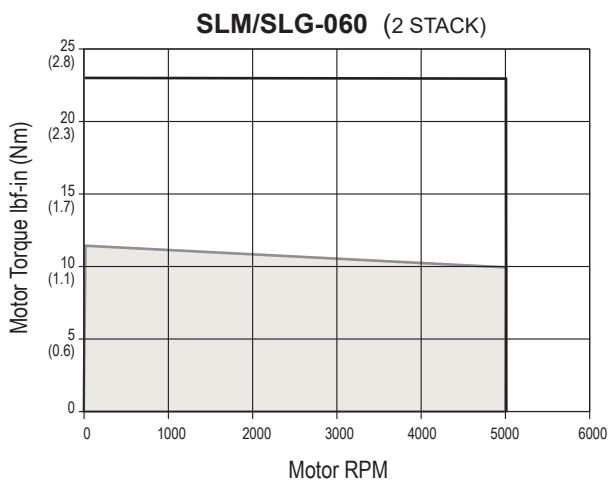
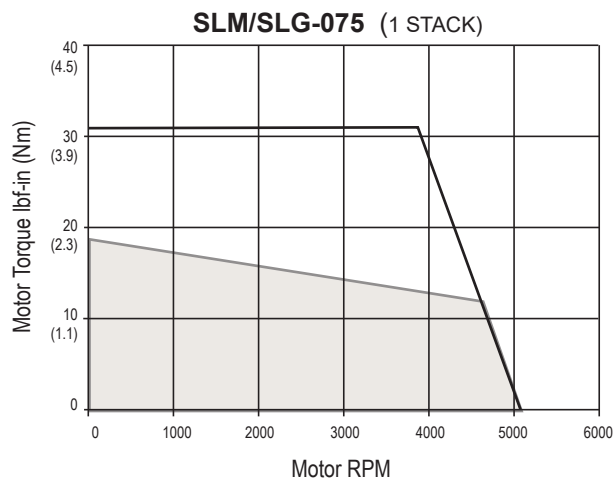
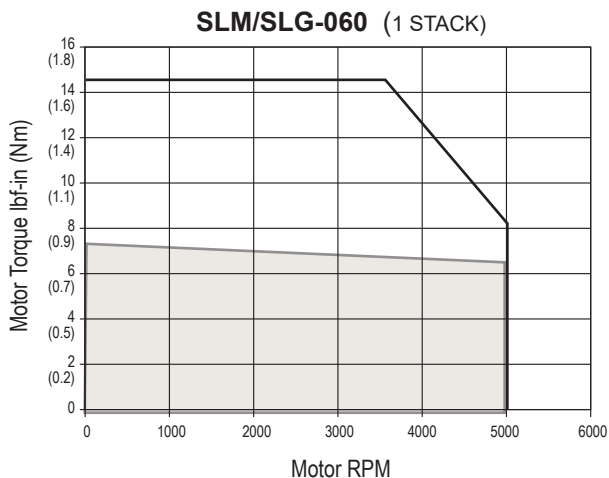

Test data derived using NEMA recommended aluminum heatsink 10" x 10" x 1/4" on SLM/SLG060 and 10" x 10" x 3/8" on SLM/SLG075 at 25° C ambient. For gearmotors, divide speed by gear ratio; multiply torque by gear ratio and efficiency. Efficiencies: 1 Stage = 0.91, 2 Stage = 0.86

SLM Series Motors/SLG Series Gearmotors

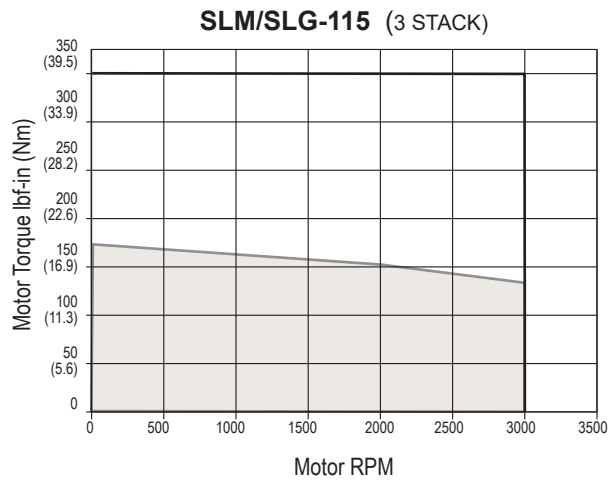
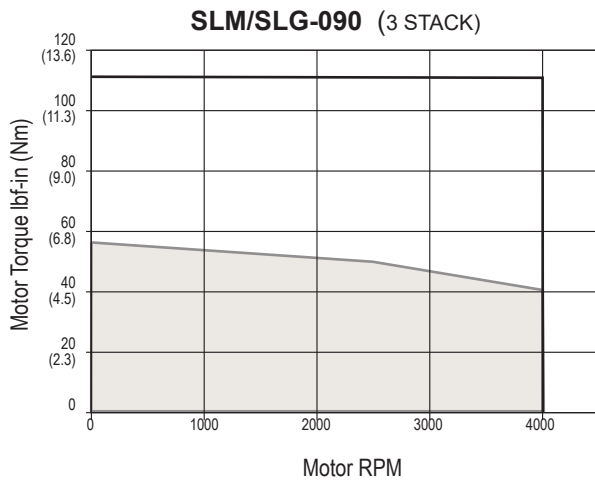
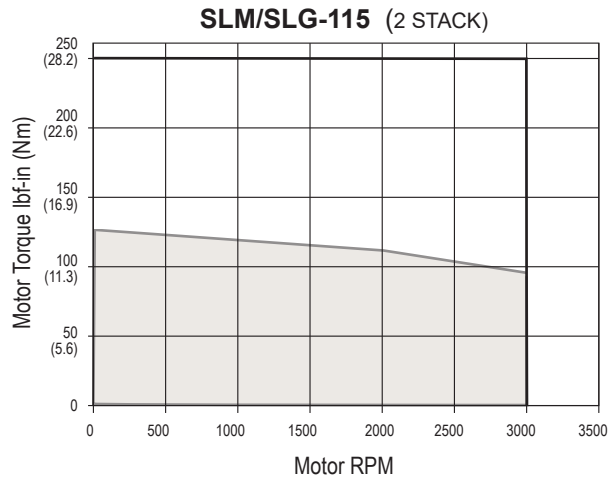
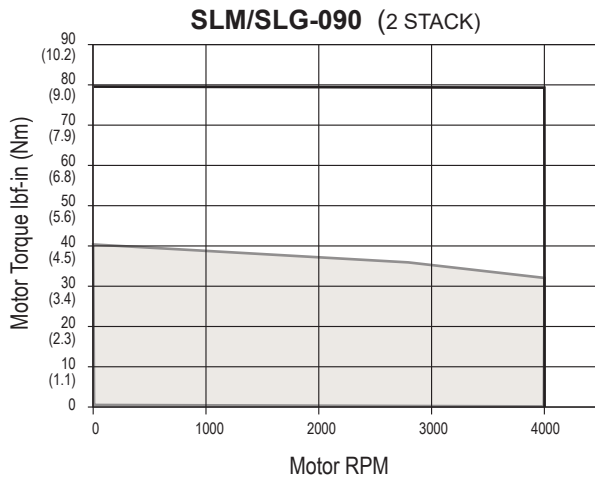
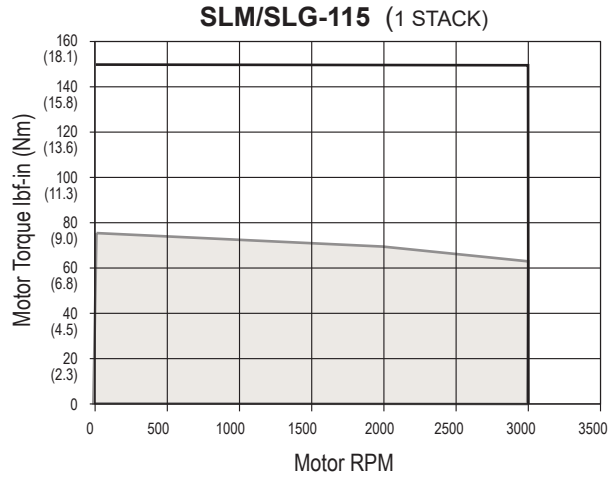
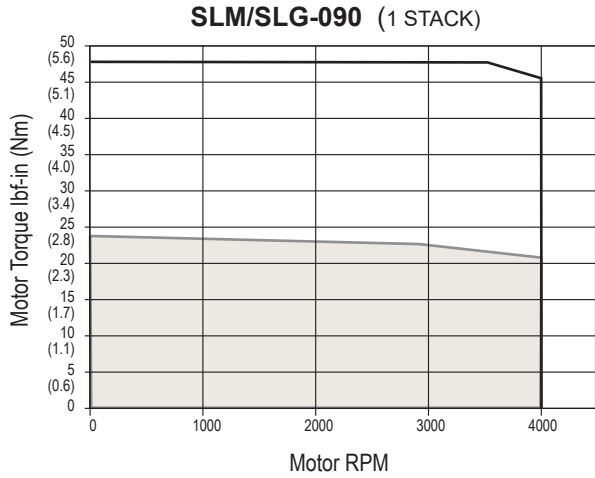

Test data derived using NEMA recommended aluminum heatsink 10" x 10" x 3/8" on SLM/SLG090 and 12" x 12" x 1/2" on SLM/SLG115 at 25°C ambient.
 For gearmotors, divide speed by gear ratio; multiply torque by gear ratio and efficiency. Efficiencies: 1 Stage = 0.91, 2 Stage = 0.86

— Peak Torque
 ■ Continuous Torque

SLM Series Motors/SLG Series Gearmotors

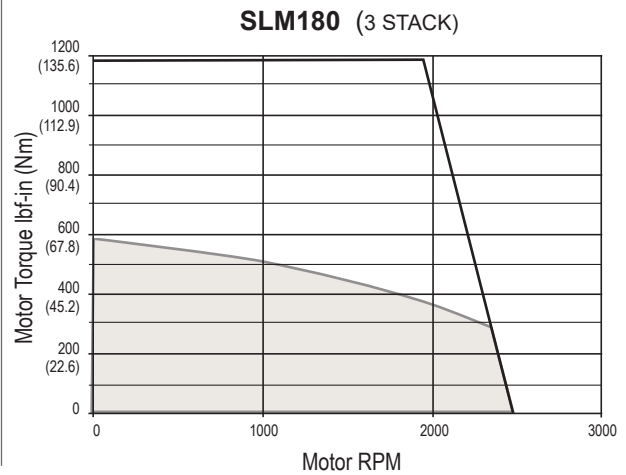
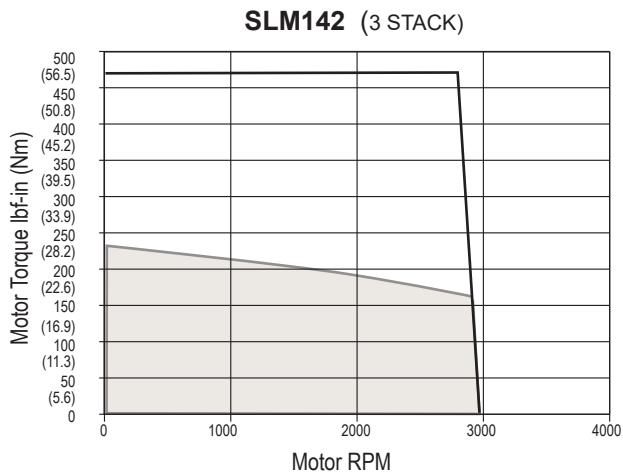
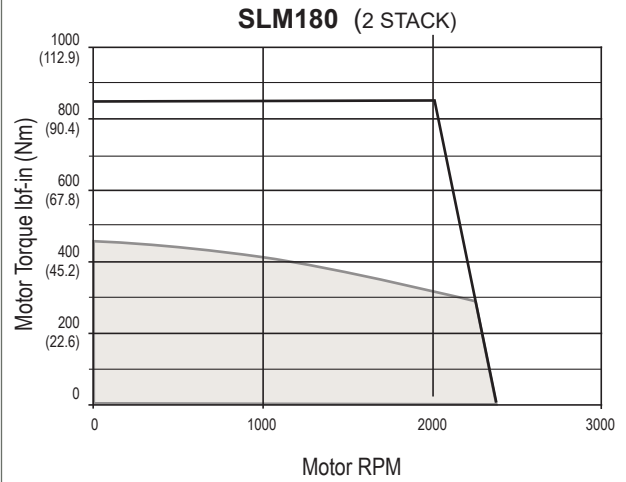
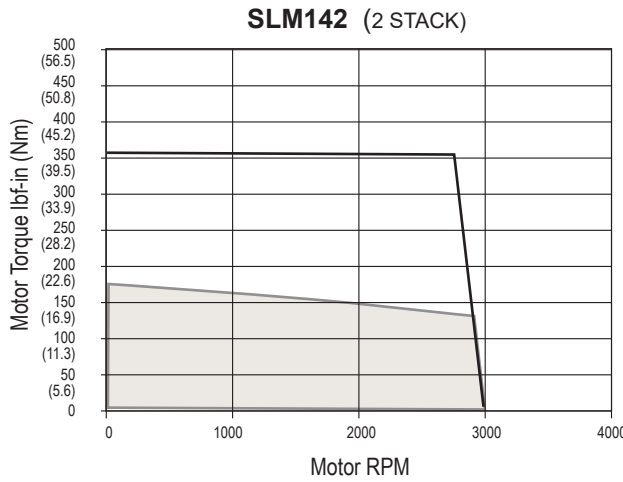
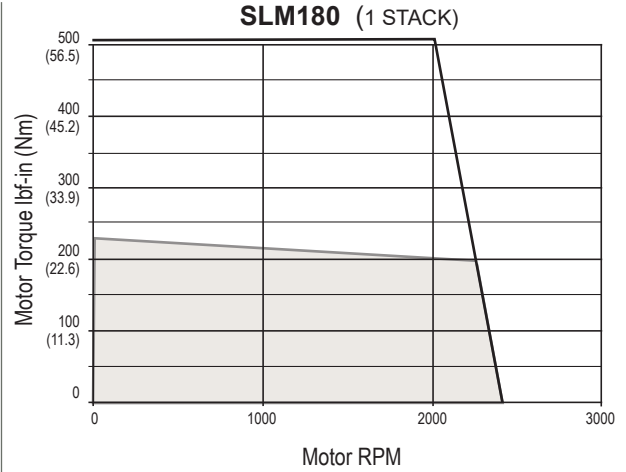
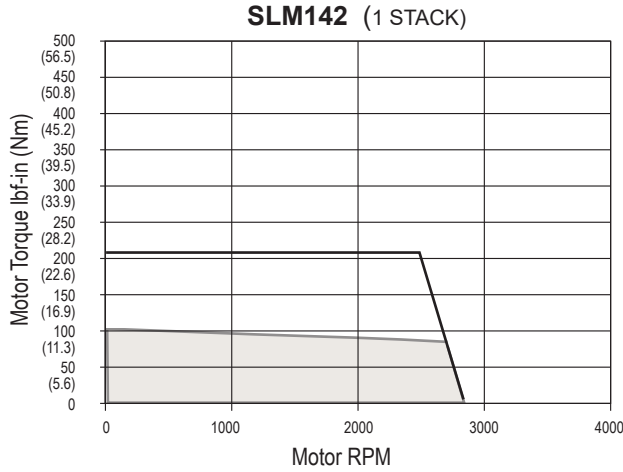

Test data derived using NEMA recommended aluminum heatsink 12" x 12" x 1/2" on SLM142 at 25°C ambient.

Test data derived using NEMA recommended aluminum heatsink 16" x 16" x 1" on SLM180 at 25°C ambient

 Peak Torque
 Continuous Torque

Options

Motor Speed

All Exlar T-LAM motors and actuators carry a standard motor speed designator (see chart). This is representative of the standard base speed of the motor for the selected bus voltage.

If the model number is created and the location for the motor speed designator is left blank, this is the base speed to which the motor will be manufactured. The model number can also be created including this standard speed designator.

Designator	Base Speed	Motor Series
-50	5000 rpm	SLM/SLG060
-40	4000 rpm	SLM/SLG075
-40	4000 rpm	SLM/SLG090
-30	3000 rpm	SLM/SLG115
-24	2400 rpm	SLM142, SLM180

Motor Stators

SLM/SLG motor options are described with a 3 digit code. The first digit calls out the stack length, the second digit signifies the rated bus voltage, and the third digit identifies the number of poles of the motor. Refer to the mechanical/electrical specifications for motor torque and actuator rated force.

8 Pole, Class 180 H

1 Stack		2 Stack		3 Stack	
118	115 Vrms	218	115 Vrms	318	115 Vrms
138	230 Vrms	238	230 Vrms	338	230 Vrms
158	400 Vrms	258	400 Vrms	358	400 Vrms
168	460 Vrms	268	460 Vrms	368	460 Vrms

IP Ratings

Please see page 175 for full description of IP Ratings.

[Return to Table of Contents](#)

Dimensions

SLM060

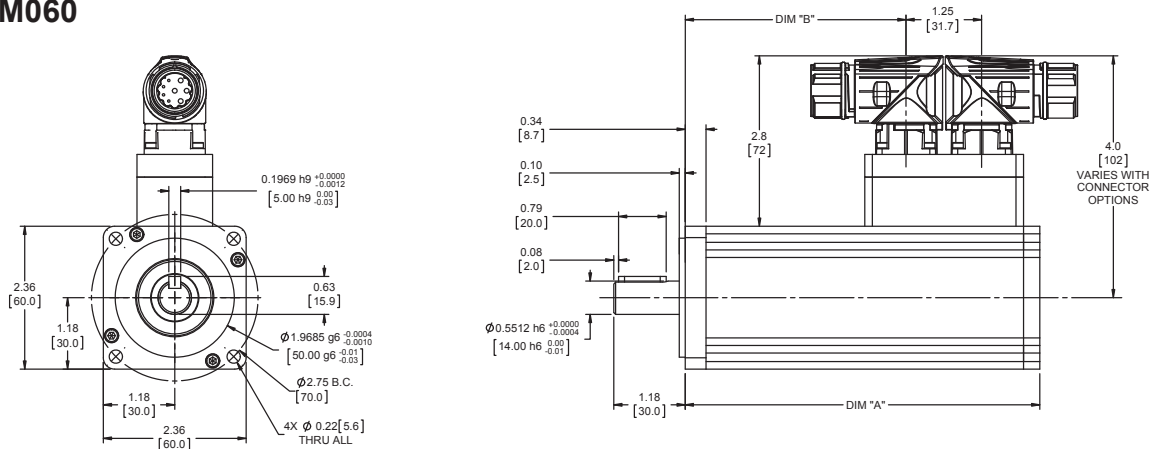

DIM	1 Stack Motor in (mm)	2 Stack Motor in (mm)	3 Stack Motor in (mm)
A	4.61 (117.1)	5.86 (148.9)	7.11 (180.6)
B	2.40 (61.1)	3.65 (92.8)	4.90 (124.6)

Add 1.02 inches (25.9 mm) to Dimensions A and B if ordering a brake.
Face plate edge is not intended for alignment of shaft (use pilot)

SLM075

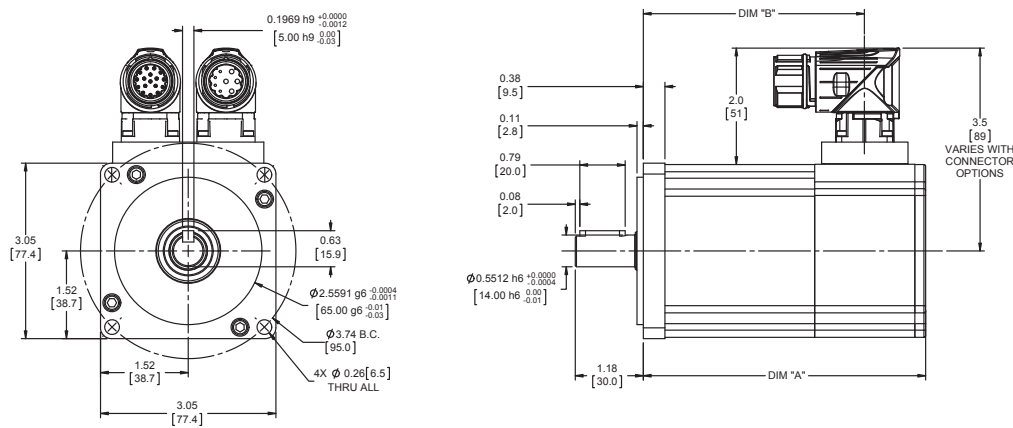

DIM	1 Stack Motor in (mm)	2 Stack Motor in (mm)	3 Stack Motor in (mm)
A	4.90 (124.5)	5.90 (149.9)	6.90 (175.3)
B	3.84 (97.6)	4.84 (123.0)	5.84 (148.4)

Add 1.28 inches (32.5 mm) to Dimensions A and B if ordering a brake.
Face plate edge is not intended for alignment of shaft (use pilot)

Due to the size of many absolute encoders, the selection of such feedback results in a larger package size than is shown in drawings. Consult Exlar for details, or refer to the drawings provided after receipt of order.

SLM Series Motors/SLG Series Gearmotors

SLM090

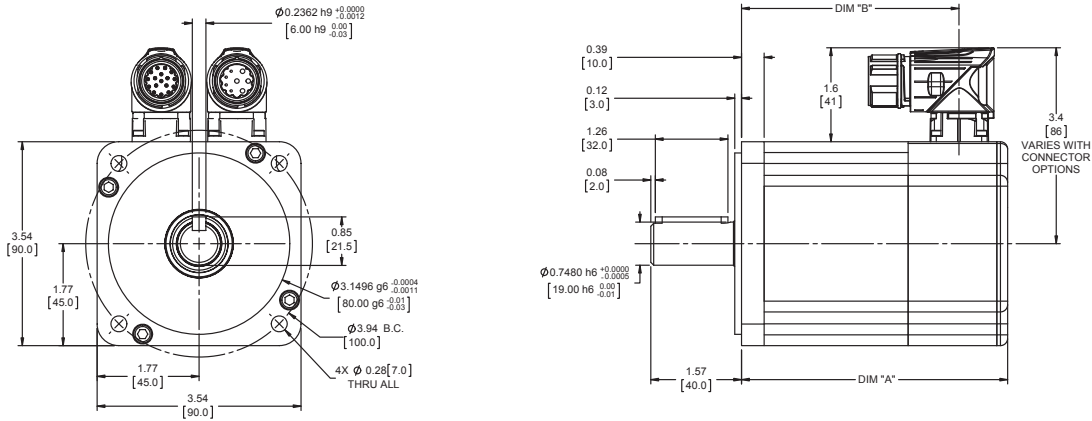

DIM	1 Stack Motor in (mm)	2 Stack Motor in (mm)	3 Stack Motor in (mm)
A	4.65 (118.1)	5.65 (143.5)	6.65 (168.9)
B	3.81 (96.8)	4.76 (121.0)	5.81 (147.6)

Add 1.31 inches (33.3 mm) to Dimensions A and B if ordering a brake.
Face plate edge is not intended for alignment of shaft (use pilot)

SLM115

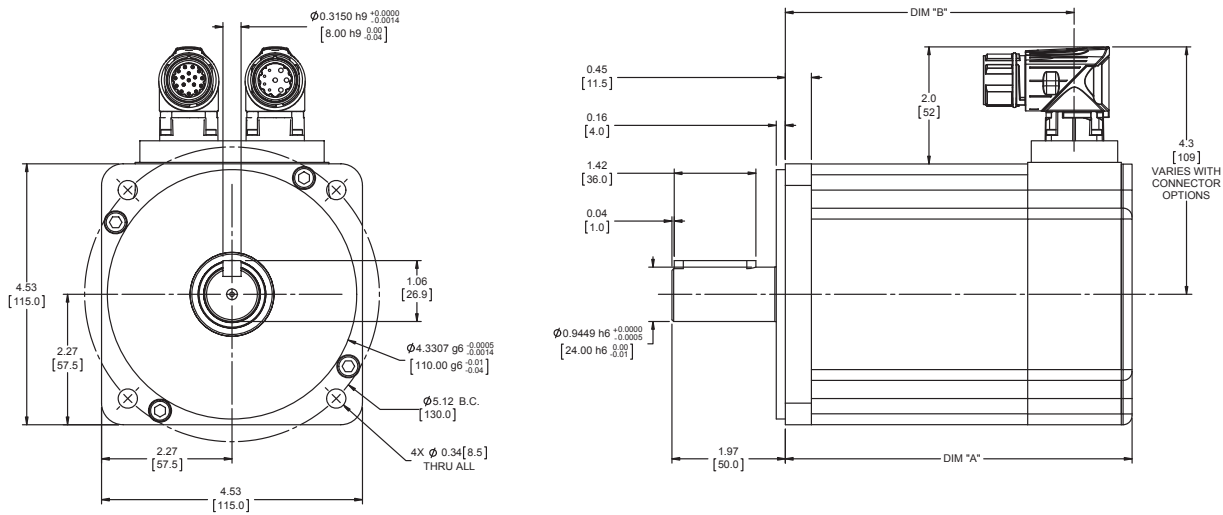

DIM	1 Stack Motor in (mm)	2 Stack Motor in (mm)	3 Stack Motor in (mm)
A	6.02 (152.9)	8.02 (203.7)	10.02 (254.5)
B	5.02 (127.5)	7.02 (178.3)	9.02 (229.1)

Add 1.73 inches (43.9 mm) to Dimensions A and B if ordering a brake.
Face plate edge is not intended for alignment of shaft (use pilot)

Due to the size of many absolute encoders, the selection of such feedback results in a larger package size than is shown in drawings. Consult Exlar for details, or refer to the drawings provided after receipt of order.

SLM Series Motors/SLG Series Gearmotors

SLM142

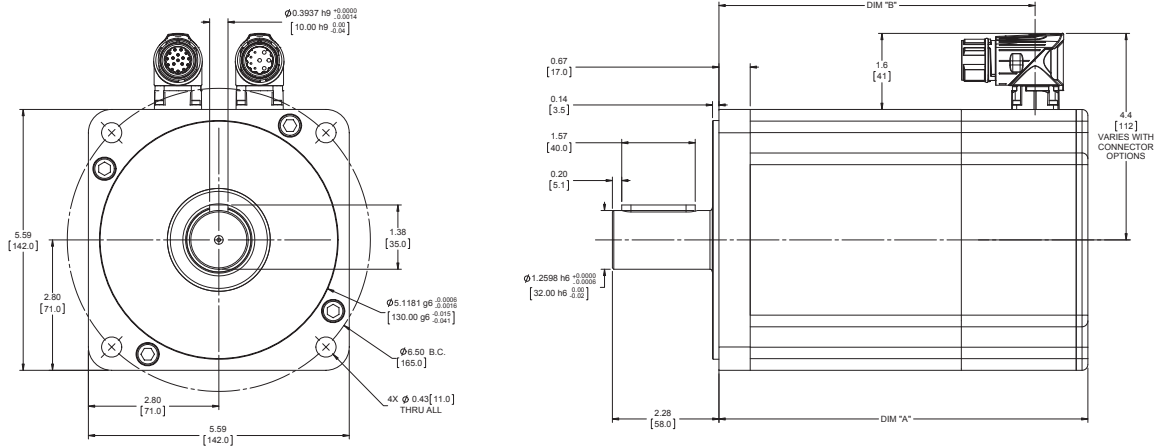

DIM	1 Stack Motor in (mm)	2 Stack Motor in (mm)	3 Stack Motor in (mm)
A	7.87 (199.9)	9.62 (244.3)	11.37 (288.8)
B	6.75 (171.3)	5.50 (139.6)	10.25 (260.2)

Add 1.66 inches (42.2 mm) to Dimensions A and B if ordering a brake.
Face plate edge is not intended for alignment of shaft (use pilot)

SLM180

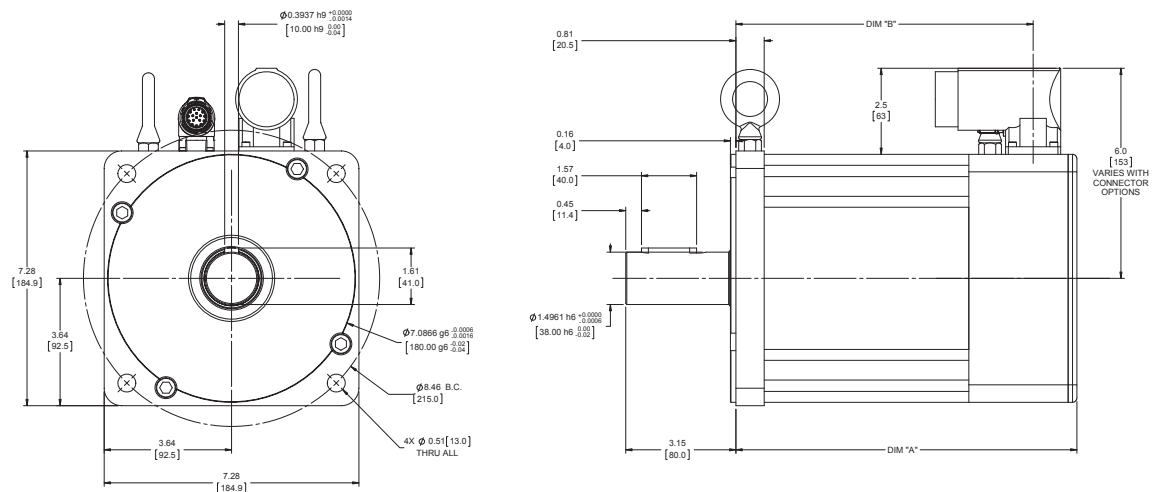

DIM	1 Stack Motor in (mm)	2 Stack Motor in (mm)	3 Stack Motor in (mm)
A	9.74 (247.4)	12.24 (310.9)	14.74 (374.4)
B	8.49 (215.6)	10.99 (279.1)	13.49 (342.6)

Add 1.90 inches (48.3 mm) to Dimensions A and B if ordering a brake.
Face plate edge is not intended for alignment of shaft (use pilot)

Due to the size of many absolute encoders, the selection of such feedback results in a larger package size than is shown in drawings. Consult Exlar for details, or refer to the drawings provided after receipt of order.

Pre-sale drawings and models are representative and are subject to change. Certified drawings and models are available for a fee. Consult your local Exlar representative for details.

SLM Series Motors/SLG Series Gearmotors

SLG060

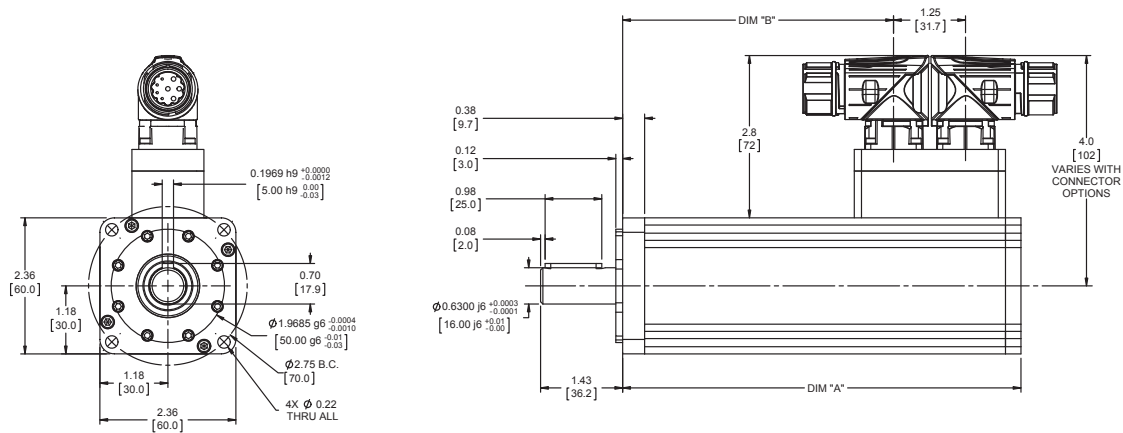

1 Stage Gearhead			
DIM	1 Stack Motor in (mm)	2 Stack Motor in (mm)	3 Stack Motor in (mm)
A	6.92 (175.6)	8.17 (207.4)	9.42 (239.1)
B	4.71 (119.6)	5.96 (151.4)	7.21 (183.1)

2 Stage Gearhead			
DIM	1 Stack Motor in (mm)	2 Stack Motor in (mm)	3 Stack Motor in (mm)
A	7.96 (202.2)	9.21 (233.9)	10.46 (265.7)
B	5.75 (146.2)	7.00 (177.9)	8.25 (209.7)

Add 1.02 inches (25.9 mm) to Dimensions A and B if ordering a brake.
Face plate edge is not intended for alignment of shaft (use pilot)

SLG075

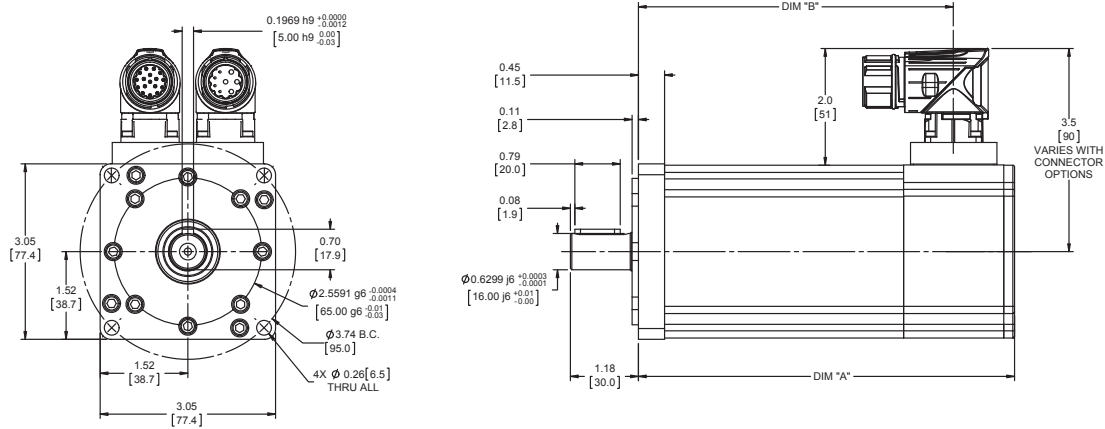

1 Stage Gearhead			
DIM	1 Stack Motor in (mm)	2 Stack Motor in (mm)	3 Stack Motor in (mm)
A	6.53 (165.9)	7.53 (191.3)	8.53 (216.7)
B	5.47 (139.0)	6.47 (164.4)	7.47 (189.8)

Add 1.23 inches (31.2 mm) to Dimensions A and B if ordering a brake.
Face plate edge is not intended for alignment of shaft (use pilot)

Due to the size of many absolute encoders, the selection of such feedback results in a larger package size than is shown in drawings. Consult Exlar for details, or refer to the drawings provided after receipt of order.

Pre-sale drawings and models are representative and are subject to change. Certified drawings and models are available for a fee. Consult your local Exlar representative for details.

SLG090

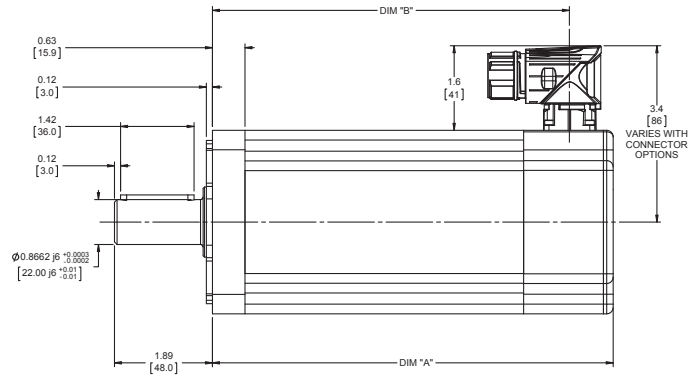
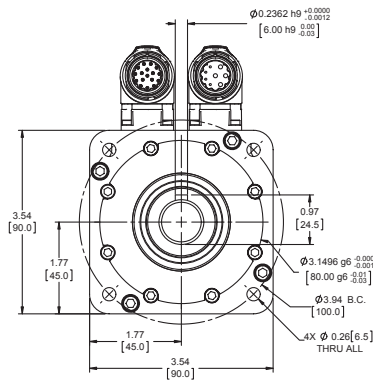

1 Stage Gearhead			
DIM	1 Stack Motor in (mm)	2 Stack Motor in (mm)	3 Stack Motor in (mm)
A	7.76 (197.1)	8.76 (222.5)	9.76 (247.9)
B	6.92 (175.8)	7.92 (201.2)	8.92 (226.6)

2 Stage Gearhead			
DIM	1 Stack Motor in (mm)	2 Stack Motor in (mm)	3 Stack Motor in (mm)
A	9.03 (229.2)	10.03 (254.6)	11.03 (280.0)
B	8.19 (207.9)	9.19 (233.3)	10.19 (258.7)

Add 1.31 inches (33.3 mm) to Dimensions A and B if ordering a brake.
Face plate edge is not intended for alignment of shaft (use pilot)

SLG115

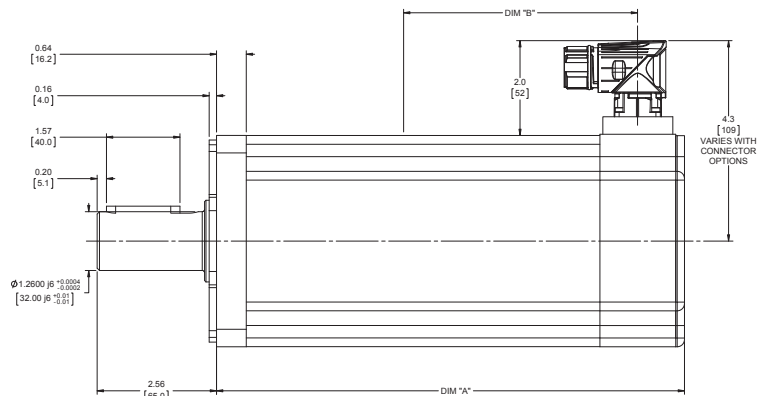
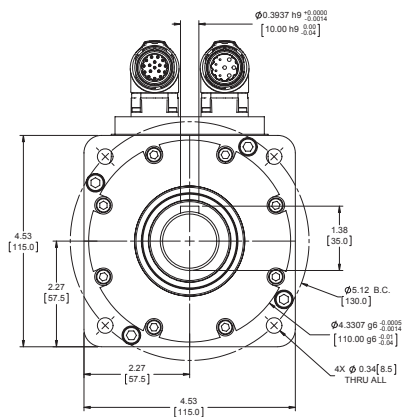

1 Stage Gearhead			
DIM	1 Stack Motor in (mm)	2 Stack Motor in (mm)	3 Stack Motor in (mm)
A	10.03 (254.8)	12.03 (305.6)	14.03 (256.4)
B	9.03 (255.0)	11.03 (280.2)	13.03 (331.0)

2 Stage Gearhead			
DIM	1 Stack Motor in (mm)	2 Stack Motor in (mm)	3 Stack Motor in (mm)
A	11.64 (295.7)	13.64 (346.5)	15.64 (397.3)
B	10.64 (270.3)	12.64 (321.1)	14.64 (372.1)

Add 1.73 inches (43.9 mm) to Dimensions A and B if ordering a brake.
Face plate edge is not intended for alignment of shaft (use pilot)

Due to the size of many absolute encoders, the selection of such feedback results in a larger package size than is shown in drawings. Consult Exlar for details, or refer to the drawings provided after receipt of order.

Pre-sale drawings and models are representative and are subject to change. Certified drawings and models are available for a fee. Consult your local Exlar representative for details.

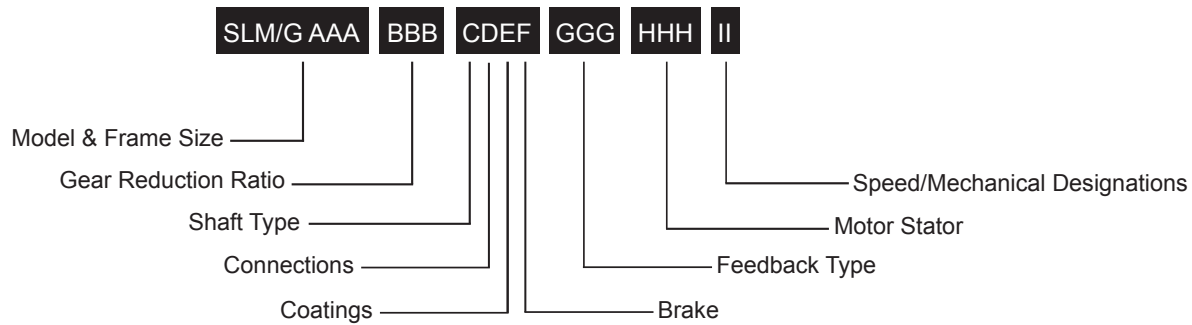

SLM/G = Model Series

SLG = SLG Series Servo Gear Motor
 SLM = SLM Series Servo Motor
 (No Gear Reduction)

AAA = Frame Size

060 = 60 mm
 075 = 75 mm
 090 = 90 mm
 115 = 115 mm
 142 = 142 mm, (SLM only)
 180 = 180 mm, (SLM only)

BBB = Gear Reduction Ratio

Blank = SLM
Single reduction ratio
 004 = 4:1
 005 = 5:1
 010 = 10:1
Double reduction ratio (N/A on 075 mm)
 016 = 16:1
 020 = 20:1
 025 = 25:1
 040 = 40:1
 050 = 50:1
 100 = 100:1

C = Shaft Type

K = Keyed

D = Connections

I = Exlar standard M23 style
 M = Manufacturer's connector ¹

E = Coating Options

G = Anodized Aluminum (standard)

F = Brake Options

B = Brake
 S = Standard no brake

GGG = Feedback Type

See page 164 for detailed information.

HHH = Motor Stator – All 8 Pole ²

118 = 1 stack	115 Vrms	158 = 1 stack	400 Vrms
218 = 2 stack		258 = 2 stack	
318 = 3 stack		358 = 3 stack	
138 = 1 stack	230 Vrms	168 = 1 stack	460 Vrms
238 = 2 stack		268 = 2 stack	
338 = 3 stack		368 = 3 stack	

II = Optional Speed and Mechanical Designations

24 = 2400 rpm, SLM142 & 180
 30 = 3000 rpm, SLM/G115
 40 = 4000 rpm, SLM075, SLM/G090
 50 = 5000 rpm, SLM/G060

NOTES:

1. Available as described in Feedback Types.
2. See page 153 for explanation of voltage, speed, stack and optimized stator options.



For options or specials not listed above or for extended temperature operation, please contact Exlar

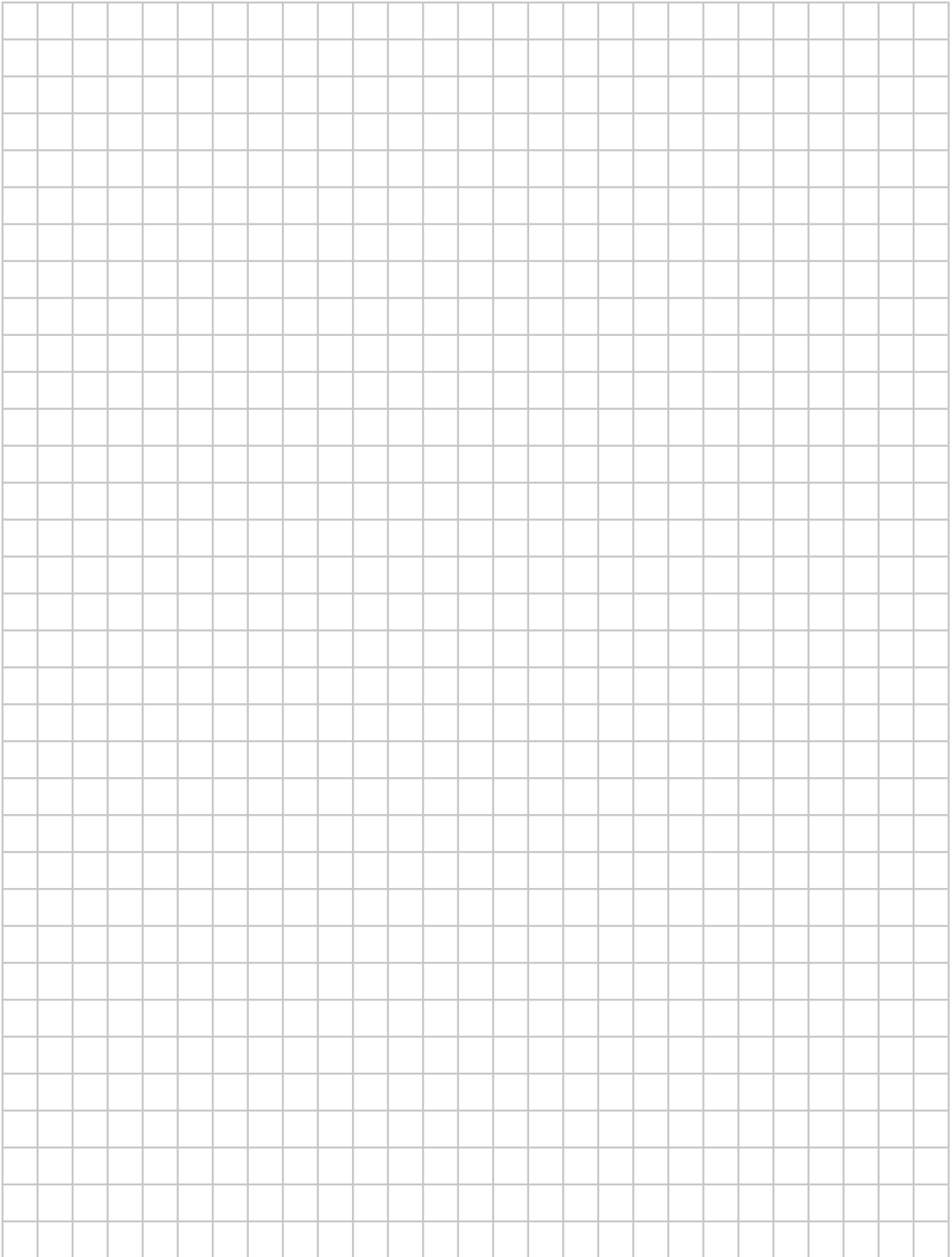

Feedback Cable Configuration - e.g. CBL-ENCOD-SMI-015

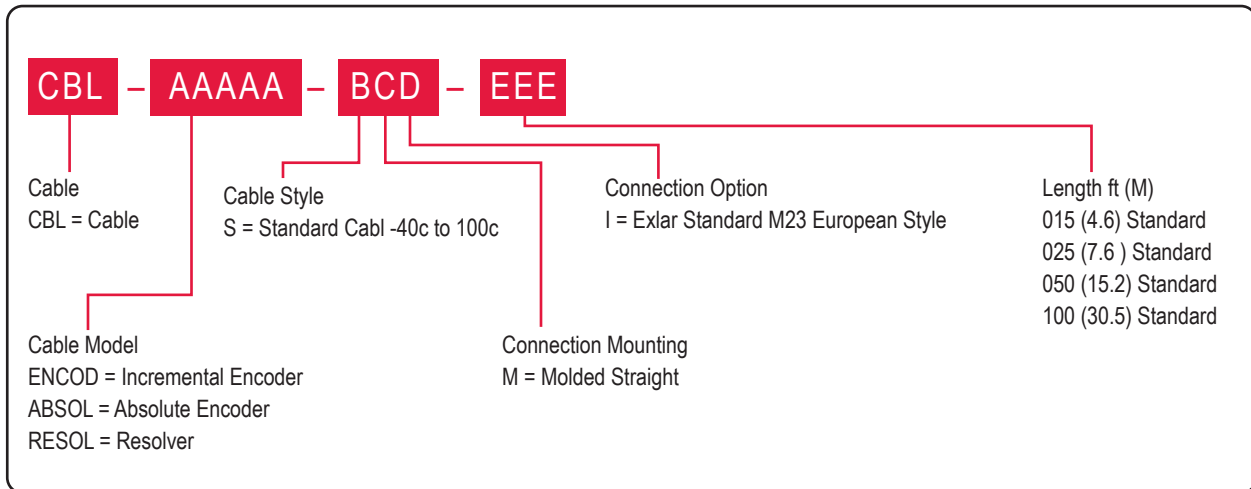

Power Cable Configuration - e.g. CBL-PWRB1-SMI-015

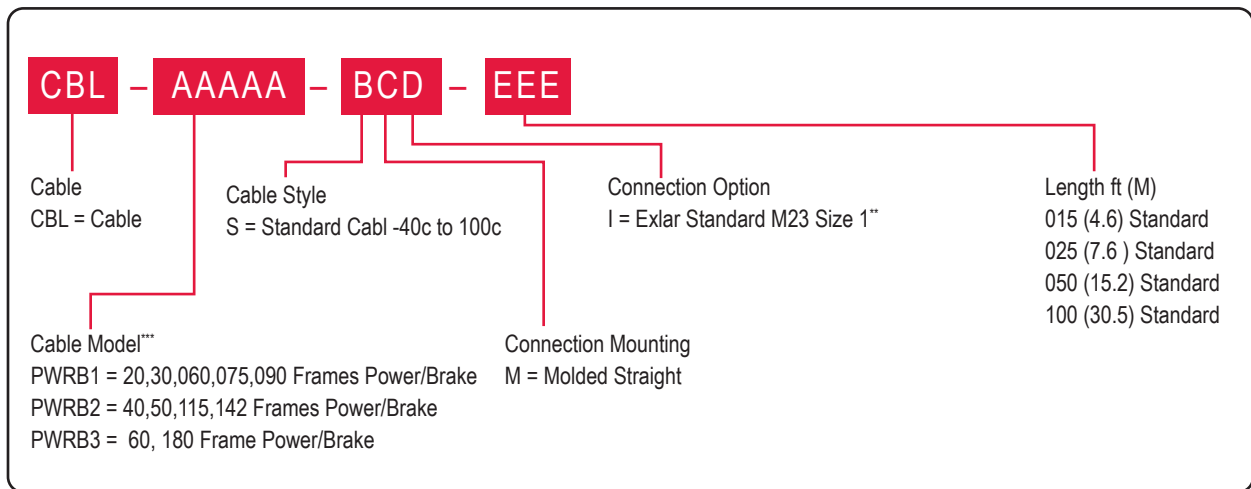

All Exlar cables rated IP65 when mated to actuator.

* Non-standard options – require longer lead times.

** PWRB3 uses M40 size 1.5.

*** Special stator winding may require a special power cable.

[Return to Table of Contents](#)

Manufacturers Feedback Cable Selection Guide

Amplifier/Drive Selected	Feedback Selected	Manufacturers Part Number
Allen-Bradley/Rockwell: All Drives	RA3 RA1, RA2, RA4	2090-CFBM7DF-CDAxyy 2090-CFBM7DF-CEAxyy
B&R Automation: All Drives	BR1 BR2	8CRxxx.12-1 8CExxx.12-1
Control Techniques: Unidrive SP/Epsilon EP	CT1/CT3 EM2/EM5 CT4/CT7 CT5 CT5	SSBCABXXXX UFCSXXX SIBAAAXXXX SRBBBBXXXX SRBBABXXXX
Unidrive M	CT5 CT5	SRBBABXXXX
Control Techniques/Epsilon	CT4/CT7 EM2/EM5	SIBAEAXXXX CFCSXXX
Elau: All Drives	EU1/EU4	SH Series Absolute Encoder Cable
Indramat/Bosch-Rexroth: DKC Series/DIAX	IN6 IN7/IN8	IKS4374 RKG4200
IndraDrive		
Kollmorgen/Danaher: All Drives	KM4 KM5 KM6	VF-SB4474N-XX VF-RA2474N-XX CF-CB7374N-XX
Lenze/AC Tech: All Drives	LZ1 LZ5 LZ6	MCS Series Absolute Encoder Cable MCS Series Resolver Cable MCS Series Incremental Encoder Cable
Parker Compumotor: All Drives	PC6 PC7 PC8 PC9/ PC0	SMH Series Incremental Encoder Cable SMH Series Resolver Cable COMPAX3 F-2C1-xx or Aries F-1A1-xx F-2B1-xx
Stober Drives: FDS/MDS 5000	SB3	Stober Absolute Encoder Cable
Siemens: 611U/Masterdrives/SMC20	SM2 SM3/SM4 SM5	6FX5002-2CF02-.... 6FX5002-2EQ10-.... 6FX5002-2CA31-....
SEW/Eurodrive: All Drives	SW1 SW3	CMP Series Resolver Cable CMP Series Absolute Encoder Cable
Yaskawa: Sigma V M	YS5	JZSP-CVP07-XX-(E)

Manufacturers Power/Brake Cables

Models:		GSX20, GSX30, SLM/SLG060, SLM/SLG090		
Amplifier/Drive Selected	Feedback Selected	Power only 4 wire	Power + Brake/Therm	Brake Cable
Allen-Bradley/Rockwell: All Drives	RA1/RA2/RA3/RA4 AB8/AB9/ABB	2090-CPWM7DF-16Axyy	2090-CPBM7DF-16Axyy	N/A
B&R Automation: All Drives	BR1/BR2	N/A	8CMxxx.12-1	N/A
Control Techniques: All Drives	CT1/CT3/CT4/CT5/CT7 EM2/EM5	MSBAAA CMDS	MBBAAA N/A	N/A CBMS
Indramat/Bosch-Rexroth: DKC Series/DIAX IndraDrive	IN1/IN5/IN6 IN7/IN8	N/A N/A	MKD/MHD Power Cable Size 1 MSK Power Cable Size 1	N/A N/A
Kollmorgen/Danaher: All Drives	KM4/KM5/KM6	N/A	6 Amp - VP-508CFAN-XX 12 Amp - VP-508CFAN-XX 20 Amp - VP-508DFAN-XX	N/A
Lenze/AC Tech: All Drives	LZ1/LZ5/LZ6	N/A	MCS Power Cable Size 1	N/A
Parker Compumotor: All Drives	PC6/PC7 PC8/PC9/PC0	N/A N/A	SMH Power Cable Size 1 P-3B1-xx	N/A N/A
Stober Drives: FDS/MDS 5000	SB3	N/A	Stober Power Cable Size 1	N/A
Siemens: All Drives with flying leads	SM2/SM3/SM4/SM5		6FX5002-5DA01-....	N/A
SEW/Eurodrive: All Drives	SW1/SW3	N/A	CMP Power Cable Size 1	N/A
Yaskawa: Sigma V Series	Y55	B1EV-XXA-E	BABEV-XXA-E	BBEV-XXA-E

*If stator current draw exceeds cable connector rating, a larger connector will be provided. Please note: Euro style connectors are size 1.5 M40 connectors. If the manufacturer does not offer a size 1.5 M40 power cable, an Exlar Power Cable must be purchased.

Manufacturers Power/Brake Cables

	GSX40, GSX50, SLM/SLG115, SLM142			GSX60 & SLM180		
	Power only 4 wire	Power + Brake/Therm	Brake Cable	Power only 4 wire	Power + Brake/Therm	Brake Cable
	2090-CPWM7DF-14Axyy	2090-CPBM7DF-14Axyy	N/A	2090-CPWM7DF-10Axyy	2090-CPBM7DF-10Axyy	N/A
	N/A	8CMxxx.12-3	N/A	N/A	8CMxxx.12-5	N/A
	MSBAAA CMMS	MBBAAA N/A	N/A CBMS	PSBxB CMLS	PBBxB N/A	N/A CBMS
	N/A N/A	MKD/MHD Power Cable Size 1 MSK Power Cable Size 1	N/A N/A	N/A N/A	MKD/MHD Power Cable Size 1.5 MSK Power Cable Size 1.5	N/A N/A
	N/A	6 Amp - VP-508CFAN-XX 12 Amp - VP-508CFAN-XX 20 Amp - VP-508DFAN-XX	N/A	N/A	Under 24 AMP use CP-508-ENBN-XXX Over 24 AMP Contact Kollmorgen Vendor	N/A
	N/A	MCS Power Cable Size 1	N/A	N/A	MCS Power Cable Size 1.5	N/A
	N/A N/A	SMH Power Cable Size 1 P-4B1-xx	N/A N/A	N/A N/A	SMH Power Cable Size 1.5 P-6B2-xx	N/A N/A
	N/A	Stober Power Cable Size 1	N/A	N/A	Stober Power Cable Size 1.5	N/A
		6FX5002-5DA11-....	N/A		6FX5002-5DA61-....	N/A
	N/A	CMP Power Cable Size 1	N/A	N/A	CM Power Cable Size 1.5	N/A
	B1EV-XXA-E	BABEV-XXA-E	BBEV-XXA-E	B3EV-XXA-E	200V=BCBEV-XX(A)-E 400V=NA	BBEV-XX (A)-E

Feedback Types for GSX, SLG, SLM

(Also specify the Amplifier/Drive Model being used when ordering)

- Standard Incremental Encoder – 2048 line (8192 cts) per rev. index pulse, Hall commutation, 5VDC
- Standard Resolver – Size 15, 1024 line (2048 cts) per rev. two pole resolver
- Motor files for use with select Emerson/CT, Rockwell /AB and Danaher/Kollmorgen Drives are available at www.exlar.com

Allen-Bradley/Rockwell: (Note: AB8, AB9 and ABB callouts are available only on spare/replacement actuators that have been previously ordered. For all new configurations using a Rockwell drive, please select from the options below. Consult Exlar for integration questions)³

Note: RA1, RA2, RA3, and RA4 callouts are not available for SLM/G motors.

- RA1 = SICK Hiperface SKM36 multi-turn absolute encoder. MPL Type V feedback (128 sin/cos) and Type 7 SpeedTec connectors and wiring when using the “M” connector option. 20 and 30 frame sizes only. (Formerly ABB)^{1,4}
- RA2 = SICK Hiperface SRM50 multi-turn absolute encoder. MPL Type M feedback (1024 sin/cos) and Type 7 SpeedTec connectors and wiring when using the “M” connector option. 40, 50 and 60 frame sizes only. (Formerly AB9)^{1,4}
- RA3 = Standard incremental encoder. MPL Type M feedback (2048 line) and Type 7 SpeedTec connector and wiring when using the “M” connector option. (Formerly AB8)⁴
- RA4 = Standard Resolver. MPL Type R feedback (4 pole) and Type 7 SpeedTec connectors and wiring when using the “M” connector option. (Formerly AB6)⁴

Advanced Motion Control:

- AM1 = Standard Incremental Encoder
- AM2 = Encoder 1000 line, w/commutation, 5 VDC
- AM3 = Standard Resolver
- AM5 = Encoder 5000 line, w/commutation, 5 VDC

Baldor:

- BD2 = Std Resolver – BSM motor wiring w/M23 connectors for ‘M’ option
- BD3 = Std Incremental Encoder – BSM motor wiring w/M23 connectors for ‘M’ option

Beckhoff:

- BE2 = EnDat Heidenhain EQN1125 multi-turn absolute encoder – AM5XX motor wiring w/M23 euro connectors for ‘M’ option

B&R Automation:

- BR1 = Standard Resolver
- BR2 = EnDat Heidenhain EQN1125/1325 multi-turn absolute encoder – 8LS/8LM motor wiring w/M23 euro connectors for ‘M’ option

Copley Controls:

- CO1 = Standard Incremental Encoder
- CO2 = Standard Resolver

Control Techniques:

- CT1 = SICK Hiperface SRM050 multi-turn absolute encoder – 40-50-60 Frame Size. FM/UM/EZ motor wiring w/M23 euro connectors for ‘M’ option
- CT3 = SICK Hiperface SKM036 multi-turn absolute encoder – 20-30 Frame Size. FM/UM/EZ motor wiring w/M23 euro connectors for ‘M’ option
- CT4 = Standard Incremental Encoder – FM/UM/EZ motor wiring w/M23 euro connectors for ‘M’ option
- CT5 = Std Resolver – FM/UM/EZ motor wiring w/M23 euro connectors for ‘M’ option
- CT7 = Encoder 5000 line, with commutation, 5 VDC – FM/UM/EZ motor wiring w/M23 euro connectors for ‘M’ option
- CT9 = Unidrive SP with EnDat Heidenhain EQN1125 multi-turn absolute encoder w/M23 connectors

Elmo Motion Control:

- EL1 = Standard Resolver
- EL2 = Standard Incremental Encoder
- EL3 = EnDat Heidenhain EQN1125 multi-turn absolute encoder

Control Techniques:

- EM2 = Std Incremental Encoder – NT motor wiring w/MS connectors for ‘M’ option
- EM5 = Encoder 5000 line, with commutation, 5 VDC – NT motor wiring w/MS connectors for ‘M’ option

Elau:

- EU1 = SICK Hiperface SRM050 multi-turn absolute encoder – 40-50-60 Frame Size. SH motor wiring w/MS connectors for ‘M’ option
- EU4 = SICK Hiperface SKM036 multi-turn absolute encoder – 20-30 Frame Size. SH motor wiring w/MS connectors for ‘M’ option.

Exlar:

- EX4 = Standard Resolver
- EX5 = Standard Resolver with PT1000 thermistor
- EX6 = EnDat Heidenhain EQN1125 multi-turn absolute encoder
- EX7 = Incremental encoder, 5000 line with commutation, 5Vdc
- EX8 = SICK Hiperface SRM50 multi-turn absolute encoder

Indramat/Bosch-Rexroth:

- IN6 = Std Resolver – MKD/MHD motor wiring w/M23 euro connectors for ‘M’ option
- IN7 = SICK Hiperface SKM036 multi-turn absolute encoder – MSK motor wiring w/M23 euro connectors for ‘M’ option – plug & play option
- IN8 = Indradrive EnDat Heidenhain EQN1125 multi-turn absolute w/M23 connectors

Continued on next page

Kollmorgen/Danaher:

- KM4 = EnDat Heidenhain EQN1325 multi-turn absolute encoder (Sine Encoder)– AKM motor wiring w/M23 Intercontec euro connectors for 'M' option
KM5 = Standard Resolver – AKM motor wiring w/M23 Intercontec euro connectors for 'M' option
KM6 = Standard Incremental Encoder – AKM motor wiring w/ M23 Intercontec euro connectors for 'M' option

Lenze/AC Tech:

- LZ1 = SICK Hiperface SRM050 multi-turn absolute encoder – MCS motor wiring w/M23 euro connectors for 'M' option
LZ5 = Standard Resolver – MCS motor wiring w/ M23 euro connectors for 'M' option
LZ6 = Standard Incremental Encoder – MCS motor wiring w/ M23 euro connectors for 'M' option

Parker Compumotor:

- PC6 = Std Incremental Encoder – SMH motor wiring w/M23 connectors for 'M' option – European only
PC7 = Std Resolver – SMH motor wiring w/M23 connectors for 'M' option – European only
PC8 = Standard Incremental Encoder – MPP series motor wiring w/PS connectors for 'M' option – US Only
PC9 = SICK Hiperface SRM050 multi-turn absolute encoder – MPP motor wiring w/PS connectors for 'M' option – US Only
PC0 = Standard Resolver – MPP motor wiring w/PS connectors for 'M' option – US Only

Schneider Electric:

- SC2 = SICK Hiperface SKM036 multi-turn absolute encoder – BSH motor wiring w/M23 euro connectors for 'M' option

Stober Drives:

- SB3 = EnDat Heidenhain EQN1125 multi-turn absolute encoder – ED/EK motor wiring w/M23 euro connectors for 'M' option
SB4 = Standard Resolver ED/EK motor wiring W/23 connector for "M" option

Siemens:

- SM2 = Standard Resolver – 1FK7 motor wiring w/M23 connectors for 'M' option
SM3 = EnDat Heidenhain EQN1325 multi-turn absolute encoder – 40-50-60 Frame Size. 1FK7 motor wiring w/M23 euro connectors for 'M' option
SM4 = EnDat Heidenhain EQN1125 multi-turn absolute encoder – 20-30 Frame Size. 1FK7 motor wiring w/M23 euro connectors for 'M' option
SM9 = Siemens Heidenhain EQN1135 Endat 2.2 (23 bit) multi-turn absolute. 1KF7 motor wiring w/M23 connectors

SEW/Eurodrive:

- SW1 = Standard Resolver – CM motor wiring w/ M23 euro connectors for 'M' option
SW3 = Hiperface Stegmann SRM050 multi-turn absolute encoder – CM motor wiring w/ M23 euro connectors for 'M' option

Yaskawa:

- YS5 = Yaskawa Sigma V absolute encoder⁴

NOTES:

1. Not compatible with Kinetix 300 Drives.
2. N/A with holding brake unless application details are discussed with your local sales representative.
3. All rotary motors to be used with Kinetix or Sercos based systems will require prior approval from Rockwell Automation.
4. Not available with rotary motors

Sizing and Selection of Exlar Linear and Rotary Actuators

Move Profiles

The first step in analyzing a motion control application and selecting an actuator is to determine the required move profile. This move profile is based on the distance to be traveled and the amount of time available in which to make that move. The calculations below can help you determine your move profile.

Each motion device will have a maximum speed that it can achieve for each specific load capacity. This maximum speed will determine which type of motion profile can be used to complete the move. Two common types of move profiles are trapezoidal and triangular. If the average velocity of the profile, is less than half the maximum velocity of the actuator, then triangular profiles can be used. Triangular Profiles result in the lowest possible acceleration and deceleration. Otherwise a trapezoidal profile can be used. The trapezoidal profile below with 3 equal divisions will result in 25% lower maximum speed and 12.5% higher acceleration and deceleration. This is commonly called a 1/3 trapezoidal profile.

The following pages give the required formulas that allow you to select the proper Exlar linear or rotary actuator for your application. The first calculation explanation is for determining the required thrust in a linear application.

The second provides the necessary equations for determining the torque required from a linear or rotary application. For rotary applications this includes the use of reductions through belts or gears, and for linear applications, through screws.

Pages are included to allow you to enter your data and easily perform the required calculations. You can also describe your application graphically and send to Exlar for sizing. Reference tables for common unit conversions and motion system constants are included at the end of the section.

Linear Move Profile Calculations

- V**_{max} = max. velocity-in/sec (m/sec)
- V**_{avg} = avg. velocity-in/sec (m/sec)
- t**_{acc} = acceleration time (sec)
- t**_{dec} = deceleration time (sec)
- t**_{cv} = constant velocity (sec)
- t**_{total} = total move time (sec)
- acc** = accel-in/sec² (m/sec²)
- dec** = decel-in/sec² (m/sec²)
- cv** = constant vel.-in/sec (m/sec)
- D** = total move distance-in (m) or revolutions (rotary)

Standard Equations

V_{avg} = **D** / **t**_{total}
If t_{acc} = **t**_{dec} **Then: V**_{max} =
 (**t**_{total} / (**t**_{total} - **t**_{acc})) (**V**_{avg})
 and
D = **Area under profile curve**
D = (1/2(**t**_{acc}+**t**_{dec})+**t**_{cv})(**V**_{max})

Trapezoidal Move Profile

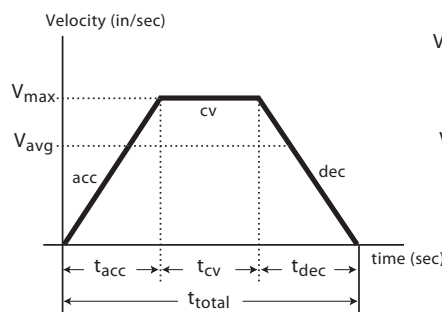

Trapezoidal Equations

If t_{acc} = **t**_{cv} = **t**_{dec} **Then:**
V_{max} = 1.5 (**V**_{avg})
D = (2/3) (**t**_{total}) (**V**_{max})
acc = **dec** = **V**_{max} / **t**_{acc}

Triangular Move Profile

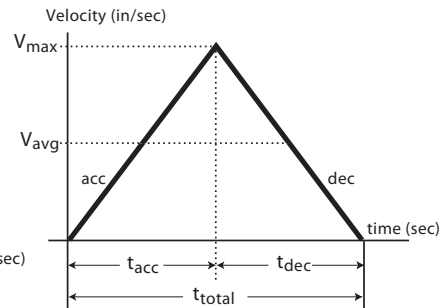

Triangular Equations

If t_{acc} = **t**_{total}/2 **Then:**
V_{max} = 2.0 (**V**_{avg})
D = (1/2) (**t**_{total}) (**V**_{max})
acc = **dec** = **V**_{max} / **t**_{acc}

Terms and (units)

- THRUST** = Total linear force-lbf (N)
 θ = Angle of inclination (deg)
Ffriction = Force from friction-lbf (N)
tacc = Acceleration time (sec)
Facc = Acceleration force-lbf (N)
v = Change in velocity-in/sec (m/s)
Fgravity = Force due to gravity-lbf (N)
 μ = Coefficient of sliding friction
Fapplied = Applied forces-lbf (N)
 (refer to table on page 136 for different materials)
WL = Weight of Load-lbf (N)
 $g = 386.4$: Acceleration of gravity - in/sec² (9.8 m/sec²)

Thrust Calculation Equations

$$\text{THRUST} = \text{Ffriction} + [\text{Facceleration}] + \text{Fgravity} + \text{Fapplied}$$

$$\text{THRUST} = \text{WL}\mu\cos\theta + [(\text{WL}/386.4)(\text{v}/\text{tacc})] + \text{WL}\sin\theta + \text{Fapplied}$$

Sample Calculations: Calculate the thrust required to accelerate a 200 pound mass to 8 inches per second in an acceleration time of 0.2 seconds. Calculate this thrust at inclination angles(θ) of 0°, 90° and 30°. Assume that there is a 25 pound spring force that is applied against the acceleration.

$$\text{WL} = 200 \text{ lbf}, \text{v} = 8.0 \text{ in/sec.}, \text{ta} = 0.2 \text{ sec.}, \text{Fapp.} = 25 \text{ lbf}, \mu = 0.15$$

$$\theta = 0^\circ$$

$$\begin{aligned} \text{THRUST} &= \text{WL}\mu\cos\theta + [(\text{WL}/386.4)(\text{v}/\text{tacc})] + \text{WL}\sin\theta + \text{Fapplied} \\ &= (200)(0.15)(1) + [(200/386.4)(8.0/0.2)] + (200)(0) + 25 \\ &= 30 \text{ lbs} + 20.73 \text{ lbs} + 0 \text{ lbs} + 25 \text{ lbs} = \mathbf{75.73 \text{ lbs force}} \end{aligned}$$

$$\theta = 90^\circ$$

$$\begin{aligned} \text{THRUST} &= \text{WL}\mu\cos\theta + [(\text{WL}/386.4)(\text{v}/\text{tacc})] + \text{WL}\sin\theta + \text{Fapplied} \\ &= (200)(0.15)(0) + [(200/386.4)(8.0/0.2)] + (200)(1) + 25 \\ &= 0 \text{ lbs} + 20.73 \text{ lbs} + 200 \text{ lbs} + 25 \text{ lbs} = \mathbf{245.73 \text{ lbs force}} \end{aligned}$$

$$\theta = 30^\circ$$

$$\begin{aligned} \text{THRUST} &= \text{WL}\mu\cos\theta + [(\text{WL}/386.4)(\text{v}/\text{tacc})] + \text{WL}\sin\theta + \text{Fapplied} \\ &= (200)(0.15)(0.866) + [(200/386.4)(8.0/0.2)] + (200)(0.5) + 25 \\ &= 26 \text{ lbs} + 20.73 \text{ lbs} + 100 + 25 = \mathbf{171.73 \text{ lbs force}} \end{aligned}$$

Thrust Calculations

Definition of thrust:

The thrust necessary to perform a specific move profile is equal to the sum of four components of force. These are the force due to acceleration of the mass, gravity, friction and applied forces such as cutting and pressing forces and overcoming spring forces.

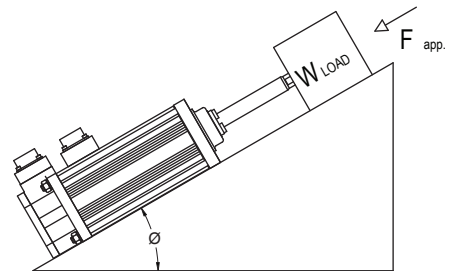

Angle of Inclination

90°	Note: at $\theta = 0^\circ$ $\cos\theta = 1$; $\sin\theta = 0$ at $\theta = 90^\circ$ $\cos\theta = 0$; $\sin\theta = 1$
0°	
-90°	

It is necessary to calculate the required thrust for an application during each portion of the move profile, and determine the worst case criteria. The linear actuator should then be selected based on those values. The calculations at the right show calculations during acceleration which is often the most demanding segment of a profile.

Motor Torque Calculations

When selecting an actuator system it is necessary to determine the required motor torque to perform the given application. These calculations can then be compared to the torque ratings of the given amplifier and motor combination that will be used to control the actuator's velocity and position.

When the system uses a separate motor and screw, like the FT actuator, the ratings for that motor and amplifier are consulted. In the case of the GSX Series actuators with their integral brushless motors, the required torque divided by the torque constant of the motor (K_t) must be less than the current rating of the GSX or SLM motor.

Inertia values and torque ratings can be found in the GSX, FT, and SLM/SLG Series product specifications.

For the GSX Series the screw and motor inertia are combined.

Motor with screw (GSX, FT, & EL)



Motor & motor with reducer (SLM/SLG & ER)



Motor with belt and pulley

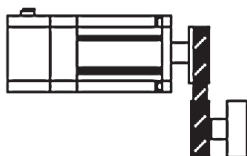

Terms and (units)

- λ = Required motor torque, lbf-in (N-m)
- λ_a = Required motor acceleration torque, lbf-in (N-m)
- F** = Applied force load, non inertial, lbf (kN)
- S** = Screw lead, in (mm)
- R** = Belt or reducer ratio
- TL** = Torque at driven load lbf-in (N-m)
- vL** = Linear velocity of load in/sec (m/sec)
- ω_L = Angular velocity of load rad/sec
- ω_m = Angular velocity of motor rad/sec
- η = Screw or ratio efficiency
- g** = Gravitational constant, 386.4 in/s² (9.75 m/s²)
- α = Angular acceleration of motor, rad/s²
- m** = Mass of the applied load, lb (N)
- JL** = Reflected Inertia due to load, lbf-in-s² (N-m-s²)
- Jr** = Reflected Inertia due to ratio, lbf-in-s² (N-m-s²)
- Js** = Reflected Inertia due to external screw, lbf-in-s² (N-m-s²)
- Jm** = Motor armature inertia, lbf-in-s² (N-m-s²)
- L** = Length of screw, in (m)
- ρ = Density of screw material, lb/in³ (kg/m³)
- r** = Radius of screw, in (m)
- π = pi (3.14159)
- C_a** = Dynamic load rating, lbf (N)

Velocity Equations

Screw drive: $V_L = \omega_m \cdot S / 2\pi$ in/sec (m/sec)

Belt or gear drive: $\omega_m = \omega_L \cdot R$ rad/sec

Torque Equations

Torque Under Load

Screw drive (GS, FT or separate screw): $\lambda = \frac{S \cdot F}{2 \cdot \pi \cdot \eta}$ lbf-in (N-m)

Belt and Pulley drive: $\lambda = T_L / R \eta$ lbf-in (N-m)

Gear or gear reducer drive: $\lambda = T_L / R \eta$ lbf-in (N-m)

Torque Under Acceleration

$\lambda_a = (J_m + J_r + (J_s + J_L)/R^2)\alpha$ lbf-in

α = angular acceleration = ((RPM / 60) x 2 π) / t_{acc} , rad/sec².

$J_s = \frac{\pi \cdot L \cdot \rho \cdot r^4}{2 \cdot g}$ lb-in-s² (N-m-s²)

Total Torque per move segment

$\lambda_T = \lambda_a + \lambda$ lbf-in (N-m)

Calculating Estimated Travel Life of Exlar Linear Actuators

Mean Load Calculations

For accurate lifetime calculations of a roller screw in a linear application, the cubic mean load should be used. Following is a graph showing the values for force and distance as well as the calculation for cubic mean load. Forces are shown for example purposes. Negative forces are shown as positive for calculation.

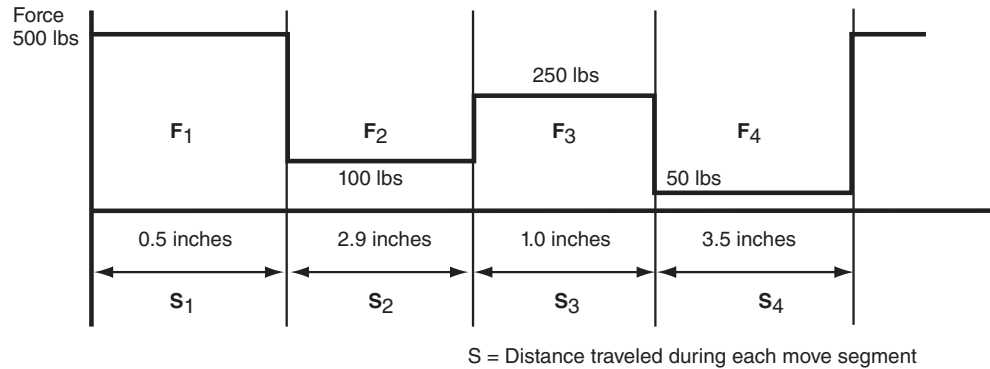

Cubic Mean Load Equation

$$F_{cml} = \sqrt[3]{\frac{F_1^3 S_1 + F_2^3 S_2 + F_3^3 S_3 + F_4^3 S_4}{S_1 + S_2 + S_3 + S_4}}$$

Value from example numbers is 217 lbs.

Lifetime Calculations

The expected L_{10} life of a roller screw is expressed as the linear travel distance that 90% of the screws are expected to meet or exceed before experiencing metal fatigue. The mathematical formula that defines this value is below. The life is in millions of inches (mm). This standard L_{10} life calculation is what is expected of 90% of roller screws manufactured and is not a guarantee. Travel life estimate is based on a properly maintained screw that is free of contaminants and properly lubricated. Higher than 90% requires de-rating according to the following factors:

95% x 0.62	96% x 0.53
97% x 0.44	98% x 0.33
99% x 0.21	

Single (non-preloaded) nut:

$$L_{10} = \left(\frac{C_a}{F_{cml}} \right)^3 \times \ell$$

Short Stroke Lifetime Calculations

If your application requires high force over a stroke length shorter than the length of the rollers/nut, please contact Exlar for derated life calculations. You may also download the article "Calculating Life Expectency" at www.exlar.com.

Note: The dynamic load rating of zero backlash, preloaded screws is 63% of the dynamic load rating of the standard non-preloaded screws. The calculated travel life of a preloaded screw will be 25% of the calculated travel life of the same size and lead of a non-preloaded screw for the same application.

Thrust Calculations

Total Thrust Calculations

Terms and (units)	Variables
THRUST = Total linear force-lbf (N)	\emptyset = Angle of inclination - deg..... = _____
F_{friction} = Force from friction-lbf (N)	t_{acc} = Acceleration time - sec..... = _____
F_{acc} = Acceleration force-lbf (N)	v = Change in velocity - in/sec (m/s)..... = _____
F_{gravity} = Force due to gravity-lbf (N)	μ = Coefficient of sliding friction = _____
F_{applied} = Applied forces-lbf (N)	W_L = Weight of Load-lbm (kg)..... = _____
386.4 = Acceleration of gravity - in/sec ² (9.8 m/sec ²)	F_{applied} = Applied forces-lbf (N) = _____

Thrust Calculation Equations

THRUST = [**F_{friction}**] + [**F_{acceleration}**] + **F_{gravity}** + **F_{applied}**
THRUST = [**W_L** x μ x $\cos\emptyset$] + [(**W_L** /386.4) x (**v** / **t_{acc}**)] + **W_L**sin \emptyset + **F_{applied}**

THRUST = [() x () x ()] + [(/386.4) x (/)] + [() ()] + ()
THRUST = [] + [() x ()] + [] + ()
 = _____ lbf.

Calculate the thrust for each segment of the move profile. Use those values in calculations below. Use the units from the above definitions.

Cubic Mean Load Calculations

$$\sqrt[3]{\frac{F_1^3 S_1 + F_2^3 S_2 + F_3^3 S_3 + F_4^3 S_4}{S_1 + S_2 + S_3 + S_4}}$$

F₁= _____ **S₁**= _____ **F₁³ S₁**= _____
F₂= _____ **S₂**= _____ **F₂³ S₂**= _____
F₃= _____ **S₃**= _____ **F₃³ S₃**= _____
F₄= _____ **S₄**= _____ **F₄³ S₄**= _____

Move Profiles may have more or less than four components. Adjust your calculations accordingly.

Torque Calculations

Terms and (units)

λ	= Torque, lb-in (N-m).....	= -----
F	= Applied Load, non inertial, lbf (N)	= -----
S	= Screw lead, in (m).....	= -----
η	= Screw or ratio efficiency (~85% for roller screws)	= -----
g	= Gravitational constant, 386 in/s ² (9.8 m/s ²).....	= -----
α	= Acceleration of motor, rad/s ²	= -----
R	= Belt or reducer ratio	= -----
T_L	= Torque at driven load, lbf-in (N-m)	= -----
V_L	= Linear velocity of load, in/sec (m/sec)	= -----
ω_L	= Angular velocity of load, rad/sec.....	= -----
ω_m	= Angular velocity of motor, rad/sec.....	= -----
m	= Mass of the applied load, lbm (kg).....	= -----
J_R	= Reflected Inertia due to ratio, lb-in-s ² (N-m-s ²)	= -----
J_S	= Reflected Inertia due to screw, lb-in-s ² (N-m-s ²)	= -----
J_L	= Reflected Inertia due to load, lb-in-s ² (N-m-s ²).....	= -----
J_M	= Motor armature inertia, lb-in-s ² (N-m-s ²)	= -----
π	= pi	= 3.14159
K_t	= Motor Torque constant, lb-in/amp (N-m/amp).....	= -----

* For the GS Series J_S and J_M are one value from the GS Specifications.

Torque Equations

Torque From Calculated Thrust.

$$\lambda = \frac{SF}{2 \cdot \pi \cdot \eta} \text{ lb-in (N-m)} = (\quad) \times (\quad) / 2\pi (0.85) = (\quad) \times (\quad) / 5.34 = \text{-----}$$

Torque Due To Load, Rotary.

Belt and pulley drive: $\lambda = T_L / R \eta$ lbf-in (N-m)

Gear or gear reducer drive: $\lambda = T_L / R\eta$ lbf-in (N-m)

Torque During Acceleration due to screw, motor, load and reduction, linear or rotary.

$$I = (J_m + (J_S + J_L) / R^2) \alpha \text{ lb-in (N-m)} = [(\quad) + (\quad + \quad) / (\quad)] (\quad) = \text{-----}$$

Total Torque = Torque from calculated Thrust + Torque due to motor, screw and load

$$(\quad) + (\quad) + (\quad) = \text{-----}$$

$$\text{Motor Current} = \lambda / K_t = (\quad) / (\quad) = \text{-----}$$

Exlar Application Worksheet

Send to:
Exlar Automation
Email: cha_applications@curtisswright.com
Fax: (952) 368-4877
Attn: Applications Engineering

Date: _____ Company Name: _____

Address: _____

City: _____ State: _____ Zip Code: _____

Phone: _____ Fax: _____

Contact: _____ Title: _____

Sketch/Describe Application

Velocity vs. Time

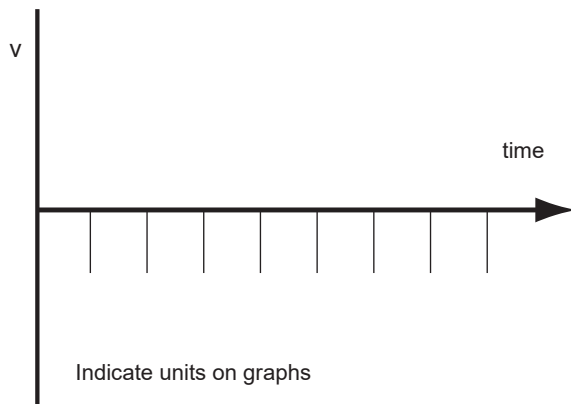

Force or Torque vs. Distance

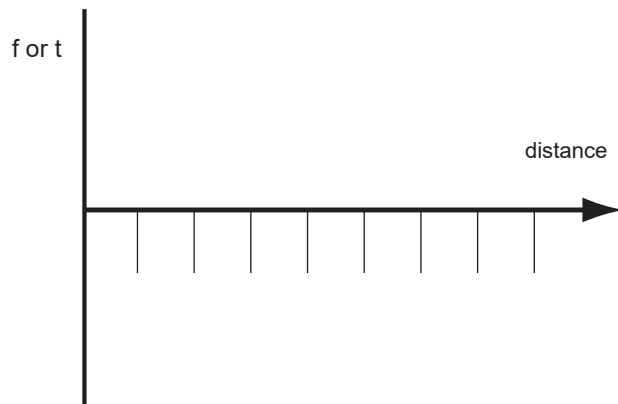

Exlar Application Worksheet

Date: _____ Contact: _____ Company: _____

Stroke & Speed Requirements

Maximum Stroke Needed _____ inches (mm), revs
Index Stroke Length _____ inches (mm), revs
Index Time _____ sec
Max Speed Requirements _____ in/sec (mm/sec), revs/sec
Min Speed Requirements _____ in/sec (mm/sec), revs/sec
Required Positional Accuracy _____ inches (mm), arc min

Load & Life Requirements

Gravitational Load _____ lb (N)
External Applied Load _____ lbf (N)
Inertial Load _____ lbf (N)
Friction Load _____ lbf (N)
Rotary Inertial Load _____ lbf-in-sec^2 (Kg-m^2)
or rotary mass, radius of gyr. _____ lb (kg) _____ in (mm)
Side Load (rot. or lin. actuator) _____ lb (N)
Force Direction _____ Extend _____ Retract _____ Both
Actuator Orientation _____ Vertical Up _____ Vertical Down _____ Horizontal
_____ Fixed Angle _____ Degrees from Horizontal
_____ Changing Angle _____ to _____
Cycling Rate _____ Cycles/min/hr/day
Operating Hours per Day _____ Hours
Life Requirement _____ Cycles/hr/inches/mm

Configuration

Mounting: _____ Side _____ Flange _____ Ext Tie Rod _____ Clevis _____ Trunnion
Rod End: _____ Male _____ Female _____ Sph Rod Eye _____ Rod Eye _____ Clevis
Rod Rotation Limiting: _____ Appl Inherent _____ External Required
Holding Brake Required: _____ Yes _____ No
Cable Length: _____ ft (m)

Reference Tables

Rotary Inertia

To obtain a conversion from A to B, multiply by the value in the table.

B	Kg-m ²	Kg-cm ²	g-cm ²	kgf-m-s ²	kgf-cm-s ²	gf-cm-s ²	oz-in ²	ozf-in-s ²	lb-in ²	lbf-in-s ²	lb-ft ²	lbf-ft-s ²
A												
Kg-m ²	1	10 ⁴	10 ⁷	0.10192	10.1972	1.01972x10 ⁴	5.46745x10 ⁴	1.41612x10 ²	3.41716x10 ³	8.850732	23.73025	0.73756
Kg-cm ²	10 ⁻⁴	1	10 ³	1.01972x10 ⁵	1.01972x10 ³	1.01972	5.46745	1.41612x10 ⁻²	0.341716	8.85073x10 ⁻⁴	2.37303x10 ⁻³	7.37561x10 ⁻⁵
g-cm ²	10 ⁻⁷	10 ⁻³	1	1.01972x10 ⁻⁸	1.01972x10 ⁻⁶	1.01972x10 ⁻³	5.46745x10 ⁻³	1.41612x10 ⁻⁵	3.41716x10 ⁻⁴	8.85073x10 ⁻⁷	2.37303x10 ⁻⁶	7.37561x10 ⁻⁸
kgf-m-s ²	9.80665	9.80665x10 ⁴	9.80665x10 ⁷	1	10 ²	10 ⁵	5.36174x10 ⁵	1.388674x10 ³	3.35109x10 ⁴	86.79606	2.32714x10 ²	7.23300
kgf-cm-s ²	9.80665x10 ⁻²	9.80665x10 ²	9.80665x10 ⁵	10 ⁻²	1	10 ⁵	5.36174 x10 ³	13.8874	3.35109x10 ⁻²	0.86796	2.32714	7.23300x10 ⁻²
gf-cm-s ²	9.80665x10 ⁻⁵	0.980665	9.80665x10 ²	10 ⁻⁵	10 ⁻³	1	5.36174	1.38874 x10 ⁻²	0.335109	8.67961x10 ⁻⁴	2.32714x10 ⁻³	7.23300x10 ⁻⁵
oz-in ²	1.82901x10 ⁻⁵	0.182901	1.82901x10 ²	1.86505x10 ⁶	1.86505x10 ⁻⁴	0.186506	1	2.59008 x10 ⁻³	6.25 x10 ⁻²	1.61880x10 ⁻⁴	4.34028x10 ⁻⁴	1.34900x10 ⁻³
oz-in-s ²	7.06154x10 ⁻³	70.6154	7.06154x10 ⁴	7.20077x10 ⁴	7.20077x10 ⁻²	72.0077	3.86089x10 ²	1	24.13045	6.25 x10 ⁻²	0.167573	5.20833x10 ⁻⁴
lb-in ²	2.92641x10 ⁻⁴	2.92641	2.92641x10 ³	2.98411x10 ⁵	2.98411x10 ³	2.98411	16	4.14414 x10 ²	1	2.59008x10 ⁻³	6.94444x10 ⁻³	2.15840x10 ⁻⁴
lbf-in-s ²	0.112985	1.129x10 ³	1.12985x10 ⁶	1.15213x10 ²	1.15213	1.51213 x10 ³	6.1774 x10 ³	16	3.86088x10 ²	1	2681175	8.3333x10 ⁻²
lbf-ft ²	4.21403x10 ⁻²	4.21403x10 ²	4.21403x10 ⁵	4.29711x10 ³	0.429711	4.297114	2.304 x10 ³	5.96755	144	0.372971	1	3.10809x10 ⁻²
lbf-ft-s ²	1.35583	1.35582x10 ⁴	1.35582x10 ⁷	0.138255	13.82551	1.38255x10 ⁴	7.41289x10 ⁴	192	4.63306x10 ³	12	32.17400	1

Torque

To obtain a conversion from A to B, multiply A by the value in the table.

B	N-m	N-cm	dyn-cm	Kg-m	Kg-cm	g-cm	oz-in	ft-lb	in-lb
A									
N-m	1	10 ⁻²	10 ⁷	0.109716	10.19716	1.019716 x10 ⁴	141.6199	0.737562	8.85074
N-cm	102	1	10 ⁵	1.019716 x10 ³	0.1019716	1.019716 x10 ²	1.41612	7.37562 x10 ⁻³	8.85074 x10 ⁻²
dyn-cm	10 ⁻⁷	10 ⁻⁵	1	1.019716 x10 ⁻⁸	1.019716 x10 ⁻⁶	1.019716 x10 ⁻³	1.41612 x10 ⁻⁵	7.2562 x10 ⁻⁸	8.85074 x10 ⁻⁷
Kg-m	9.80665	980665x10 ²	9.80665 x10 ⁷	1	10 ²	10 ⁵	1.38874 x10 ³	7.23301	86.79624
Kg-cm	9.80665x10 ⁻²	9.80665	9.80665 x10 ⁵	10 ⁻²	1	10 ³	13.8874	7.23301 x10 ⁻²	0.86792
g-cm	9.80665x10 ⁻⁵	9.80665x10 ⁻³	9.80665 x10 ²	10 ⁻⁵	10 ⁻³	1	1.38874 x10 ⁻²	7.23301 x10 ⁻⁵	8.679624 x10 ⁻⁴
oz-in	7.06155x10 ⁻³	0.706155	7.06155 x10 ⁴	7.20077 x10 ⁻⁴	7.20077 x10 ⁻²	72.077	1	5.20833 x10 ⁻³	6.250 x10 ⁻²
ft-lb	1.35582	1.35582x10 ²	1.35582 x10 ⁷	0.1382548	13.82548	1.382548 x10 ⁴	192	1	12
in-lb	0.113	11.2985	1.12985 x10 ⁶	1.15212 x10 ⁻²	1.15212	1.15212 x10 ³	16	8.33333 x10 ⁻²	1

Common Material Densities

Material	oz/in ³	gm/cm ³
Aluminum (cast or hard drawn)	1.54	2.66
Brass (cast or rolled)	4.80	8.30
Bronze (cast)	4.72	8.17
Copper (cast or hard drawn)	5.15	8.91
Plastic	0.64	1.11
Steel (hot or cold rolled)	4.48	7.75
Wood (hard)	0.46	0.80
Wood (soft)	0.28	0.58

Coefficients of Sliding Friction

Materials in contact	μ
Steel on Steel (dry)	0.58
Steel on Steel (lubricated)	0.15
Aluminum on Steel	0.45
Copper on Steel	0.36
Brass on Steel	0.44
Plastic on Steel	0.20
Linear Bearings	0.001

Warranty and Limitations of Liability

WARRANTY AND LIMITATION OF LIABILITY: Please see our warranty on our website here: [Division Policies | About | Actuation Division | Curtiss-Wright Actuation Group \(cw-actuation.com\)](#) for details.



USA & CANADA

Exlar Automation
18400 West 77th Street
Chanhassen, MN 55317
Phone: 855-620-6200 (US & Canada)
Fax: 952-368-4877

ASIA

Exlar Asia Pacific
1007 Pine City Hotel
8 Dong An Road, Xuhui District,
Shanghai 200032 China
Phone: +86 021-6495-7868

Distributed by:



www.exlar.com

Exlar® actuators are a brand of Curtiss-Wright, Sensors and Controls Division.